

TP 32-30/4-A-F-A-BQQE 1X230 50HZ Grundfos pump 98957942



Thank you for your interest in our products. Please contact us for more information, or visit our website

<https://www.lenntech.com/grundfos/TP000/98957942/TP-32-30-4-A-F-A-BQQE.html>

info@lenntech.com

tel. +31 152 610 900

fax. +31 152 616 289

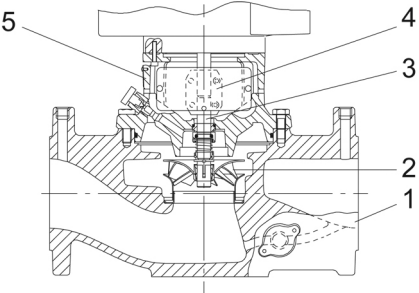
Position	Qty.	Description
	1	<p data-bbox="320 163 600 194">TP 32-30/4 A-F-A-BQQE</p>  <p data-bbox="320 483 600 515">Product No.: On request</p> <p data-bbox="320 544 1445 620">Single-stage, close-coupled, volute pump with in-line suction and discharge ports of identical diameter. The pump is of the top-pull-out design, i.e. the power head (motor, pump head and impeller) can be removed for maintenance or service while the pump housing remains in the pipework.</p> <p data-bbox="320 629 1422 680">The pump is fitted with an unbalanced rubber bellows seal. The shaft seal is according to EN 12756. Pipework connection is via PN 6/10 DIN flanges (EN 1092-2 and ISO 7005-2).</p> <p data-bbox="320 687 951 719">The pump is fitted with a fan-cooled asynchronous motor.</p> <p data-bbox="320 745 639 777">Further product details</p> <p data-bbox="320 781 400 813">Pump</p> <p data-bbox="320 817 1257 848">Pump housing and pump head are electrocoated to improve the corrosion resistance.</p> <p data-bbox="320 853 584 884">Electrocoating includes:</p> <ol data-bbox="320 889 810 994" style="list-style-type: none"> 1) Alkaline-based cleaning. 2) Pretreatment with zinc phosphate coating. 3) Cathodic electrocoating (epoxy). 4) Curing of paint film at 200-250 °C.  <ol data-bbox="320 1328 507 1473" style="list-style-type: none"> 1: Pump housing 2: Impeller 3: Shaft 4: Coupling 5: Pump head <p data-bbox="320 1503 1458 1579">The pump housing is provided with a replaceable stainless steel/PTFE neck ring to reduce the amount of liquid running from the discharge side of the impeller to the suction side. The impeller is secured with a split cone with nut.</p> <p data-bbox="320 1619 1441 1695">The pump is fitted with an unbalanced rubber bellows seal with torque transmission across the spring and around the bellows. Due to the bellows, the seal does not wear the shaft, and the axial movement is not prevented by deposits on the shaft.</p> <p data-bbox="320 1704 464 1736">Primary seal:</p> <ul data-bbox="357 1738 919 1794" style="list-style-type: none"> • Rotating seal ring material: silicon carbide (SiC) • Stationary seat material: silicon carbide (SiC) <p data-bbox="320 1796 1426 1848">This material pairing is used where higher corrosion resistance is required. The high hardness of this material pairing offers good resistance against abrasive particles.</p> <p data-bbox="320 1852 986 1883">Secondary seal material: EPDM (ethylene-propylene rubber)</p> <p data-bbox="320 1886 1219 1917">EPDM has excellent resistance to hot water. EPDM is not suitable for mineral oils.</p> <p data-bbox="320 1942 1445 1995">A circulation of liquid through the duct of the air vent screw ensures lubrication and cooling of the shaft seal.</p> <p data-bbox="320 2000 983 2031">The flanges have tappings for mounting of pressure gauges.</p>

The motor stool forms connection between the pump housing and the motor, and is equipped with a manual air vent screw for venting of the pump housing and the shaft seal chamber. The sealing between motor stool and pump housing is an O-ring.

The central part of the motor stool is provided with guards for protection against the shaft and coupling. Motor and pump shaft are connected via a shell coupling.

Motor

The motor is a totally enclosed, fan-cooled motor with principal dimensions to IEC and DIN standards. Electrical tolerances comply with IEC 60034.

The motor is flange-mounted with tapped-hole flange (FT).

Motor-mounting designation in accordance with IEC 60034-7: IM B 14, IM V 18 (Code I) / IM 3601, IM 3611 (Code II).

The motor has built-in thermal protection (PTO current and temperature sensors) in accordance with IEC 60034-11 and requires no further motor protection. The protection reacts to both slow- and quick-rising temperatures, e.g. constant overload and stalled conditions.

As the thermal protection incorporates automatic reset, the motor must be connected in a way which ensures that the automatic reset cannot cause accidents.

Technical data

Liquid:

Pumped liquid:	Water
Liquid temperature range:	-25 .. 120 °C
Liquid temperature during operation:	20 °C
Density:	998.2 kg/m ³

Technical:

Rated flow:	5.9 m ³ /h
Rated head:	1.8 m
Actual impeller diameter:	86 mm
Primary shaft seal:	BQQE
Curve tolerance:	ISO9906:2012 3B

Materials:

Pump housing:	Cast iron EN-JL1040 ASTM A48-40 B
Impeller:	Stainless steel DIN W.-Nr. 1.4301 AISI 304

Installation:

Range of ambient temperature:	-30 .. 40 °C
Maximum operating pressure:	10 bar
Flange standard:	DIN
Pipe connection:	DN 32
Pump inlet:	DN 32
Pump outlet:	DN 32
Pressure rating:	PN 6/10
(@):	220 mm
Flange size for motor:	FT75

Electrical data:

Motor type:	71A
Rated power - P2:	0.12 kW
Power (P2) required by pump:	0.12 kW
Mains frequency:	50 Hz
Rated voltage:	1 x 220-240 V
Rated current:	1.0-1.04 A
Starting current:	340-370 %
Cos phi - power factor:	0.92
Rated speed:	1430-1440 rpm
Motor efficiency at full load:	58.2-54.2 %

Position	Qty.	Description
		Number of poles: 4 Enclosure class (IEC 34-5): 55 Dust/Jetting Insulation class (IEC 85): F Others: ErP status: EuP Standalone/Prod. Net weight: 17 kg Gross weight: 20.5 kg Shipping volume: 0.04 m ³

On request TP 32-30/4 A-F-A-BQQE 50 Hz

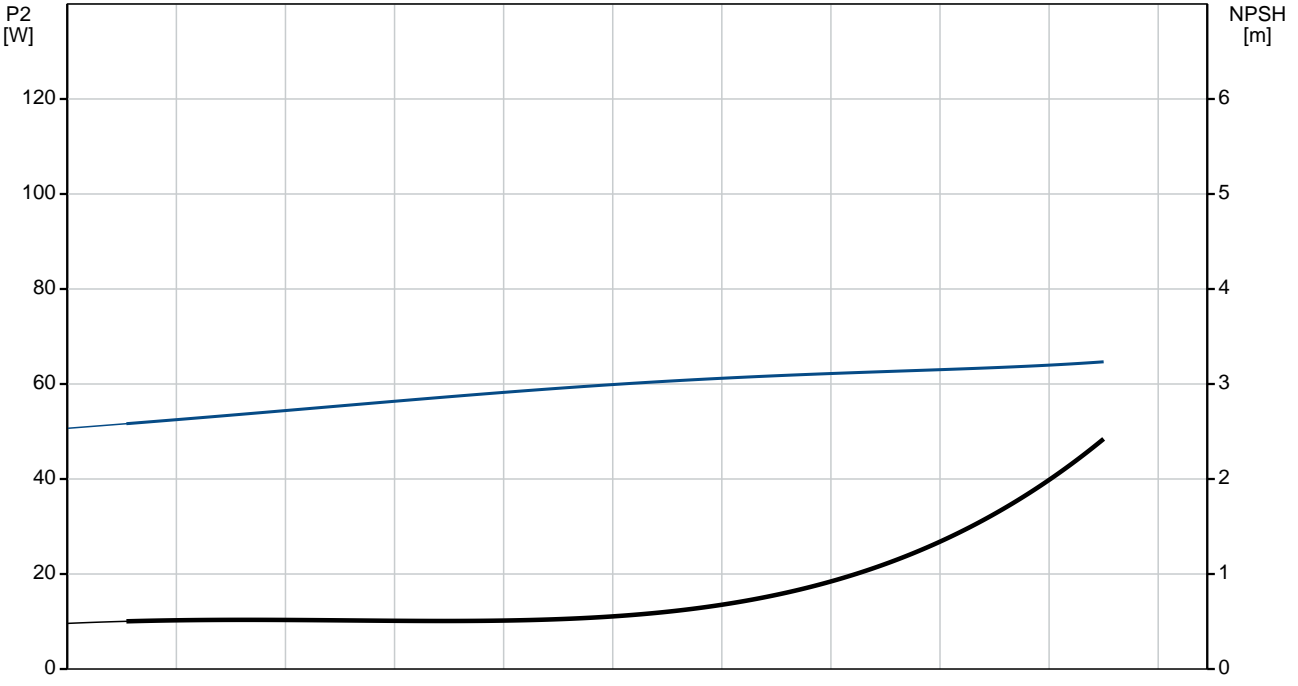
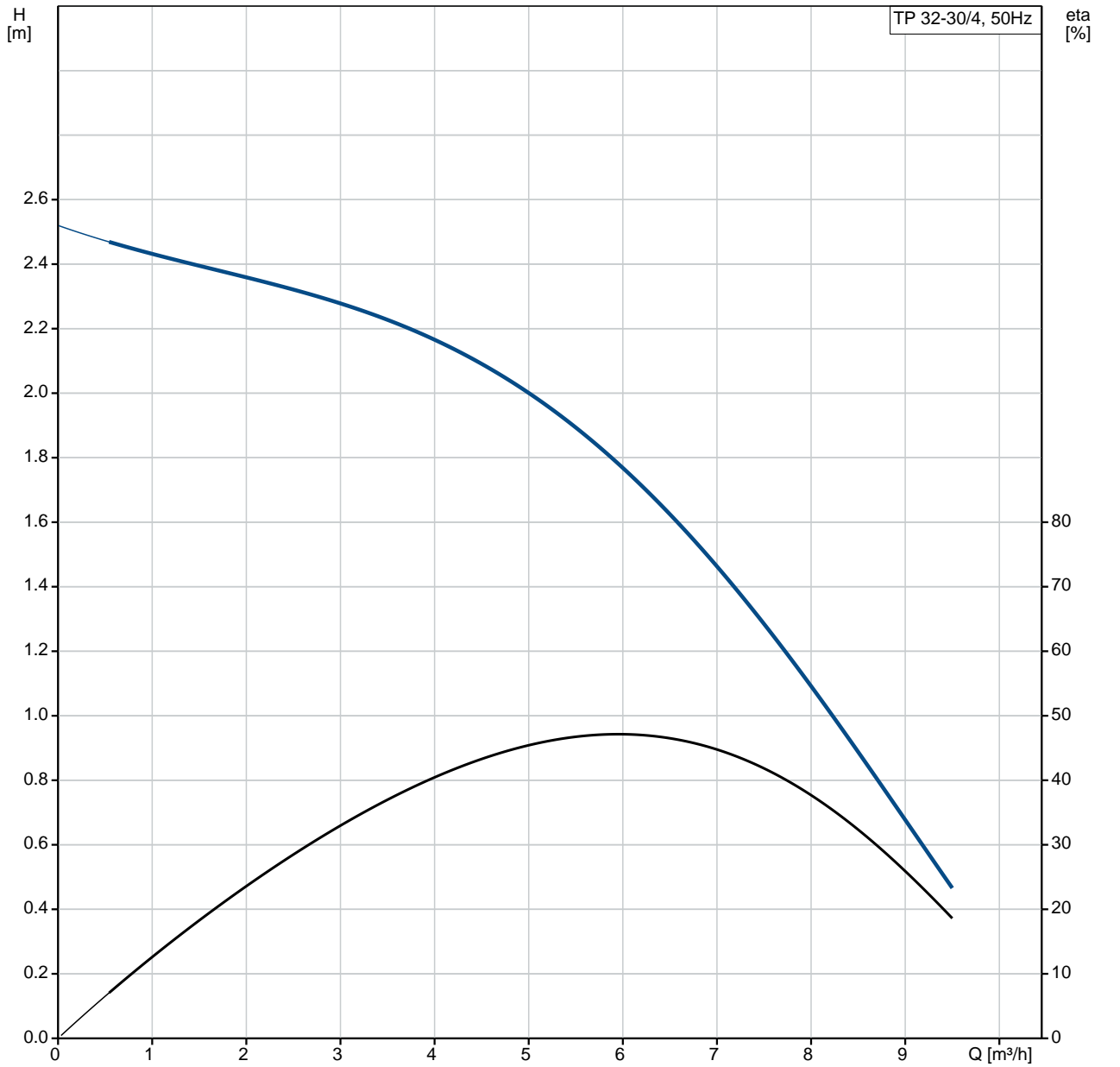

Description	Value
General information:	
Product name:	TP 32-30/4 A-F-A-BQQE
Product No:	On request
EAN number:	On request
Technical:	
Rated flow:	5.9 m ³ /h
Rated head:	1.8 m
Head max:	30 dm
Actual impeller diameter:	86 mm
Primary shaft seal:	BQQE
Curve tolerance:	ISO9906:2012 3B
Pump version:	A
Model:	A
Materials:	
Pump housing:	Cast iron EN-JL1040 ASTM A48-40 B
Impeller:	Stainless steel DIN W.-Nr. 1.4301 AISI 304
Material code:	A
Installation:	
Range of ambient temperature:	-30 .. 40 °C
Maximum operating pressure:	10 bar
Flange standard:	DIN
Pipe connection:	DN 32
Pump inlet:	DN 32
Pump outlet:	DN 32
Pressure rating:	PN 6/10 (@) 220 mm
Flange size for motor:	FT75
Connect code:	F
Liquid:	
Pumped liquid:	Water
Liquid temperature range:	-25 .. 120 °C
Liquid temperature during operation:	20 °C
Density:	998.2 kg/m ³
Electrical data:	
Motor type:	71A
Rated power - P2:	0.12 kW
Power (P2) required by pump:	0.12 kW
Mains frequency:	50 Hz
Rated voltage:	1 x 220-240 V
Rated current:	1.0-1.04 A
Starting current:	340-370 %
Cos phi - power factor:	0.92
Rated speed:	1430-1440 rpm
Motor efficiency at full load:	58.2-54.2 %
Number of poles:	4
Enclosure class (IEC 34-5):	55 Dust/Jetting
Insulation class (IEC 85):	F
Motor protec:	PTO
Motor No:	98714254
Others:	
ErP status:	EuP Standalone/Prod.
Net weight:	17 kg
Gross weight:	20.5 kg
Shipping volume:	0.04 m ³

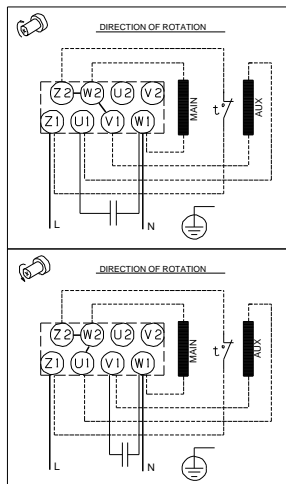
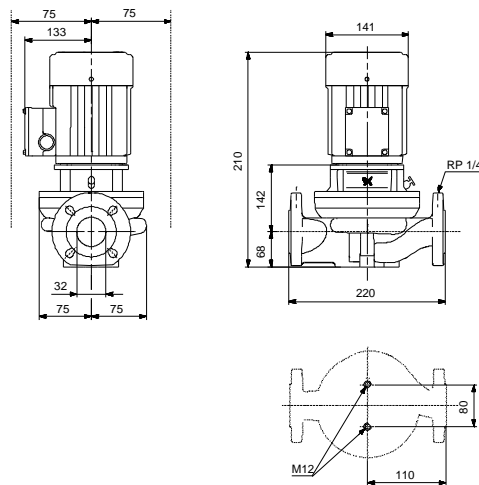
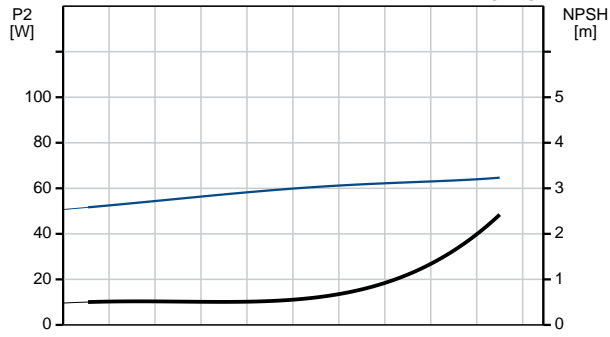
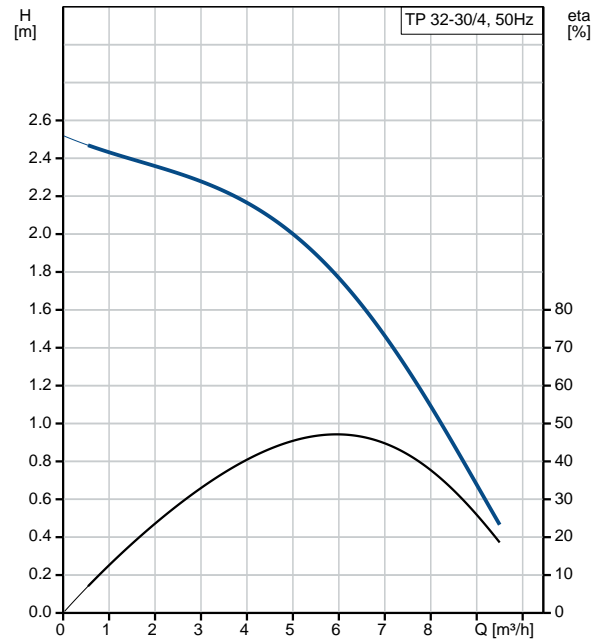

On request TP 32-30/4 A-F-A-BQQE 50 Hz

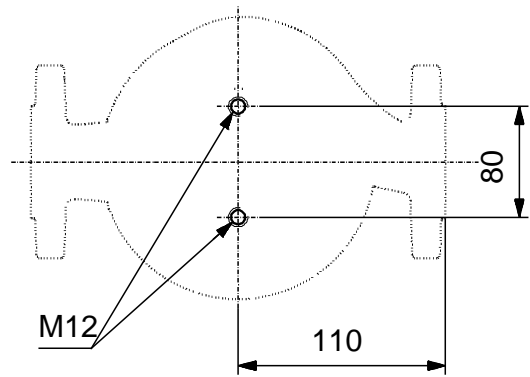
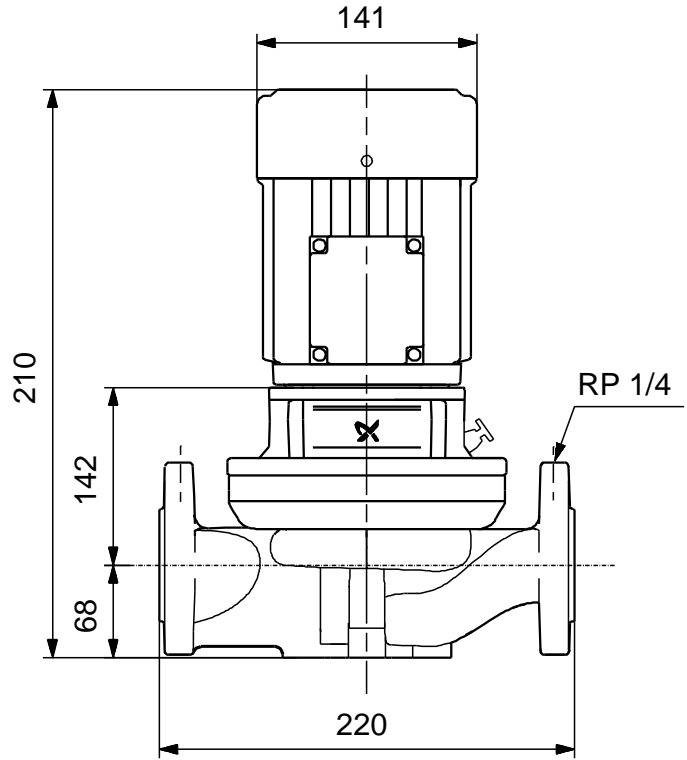
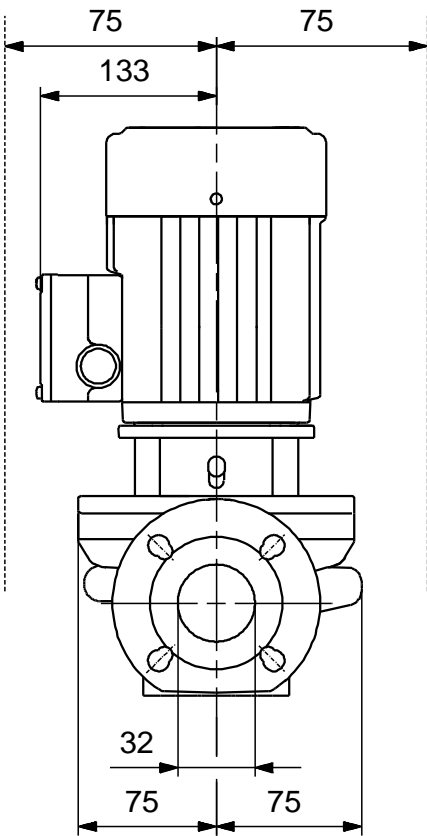

Note! All units are in [mm] unless others are stated.
Disclaimer: This simplified dimensional drawing does not show all details.

Exploded view

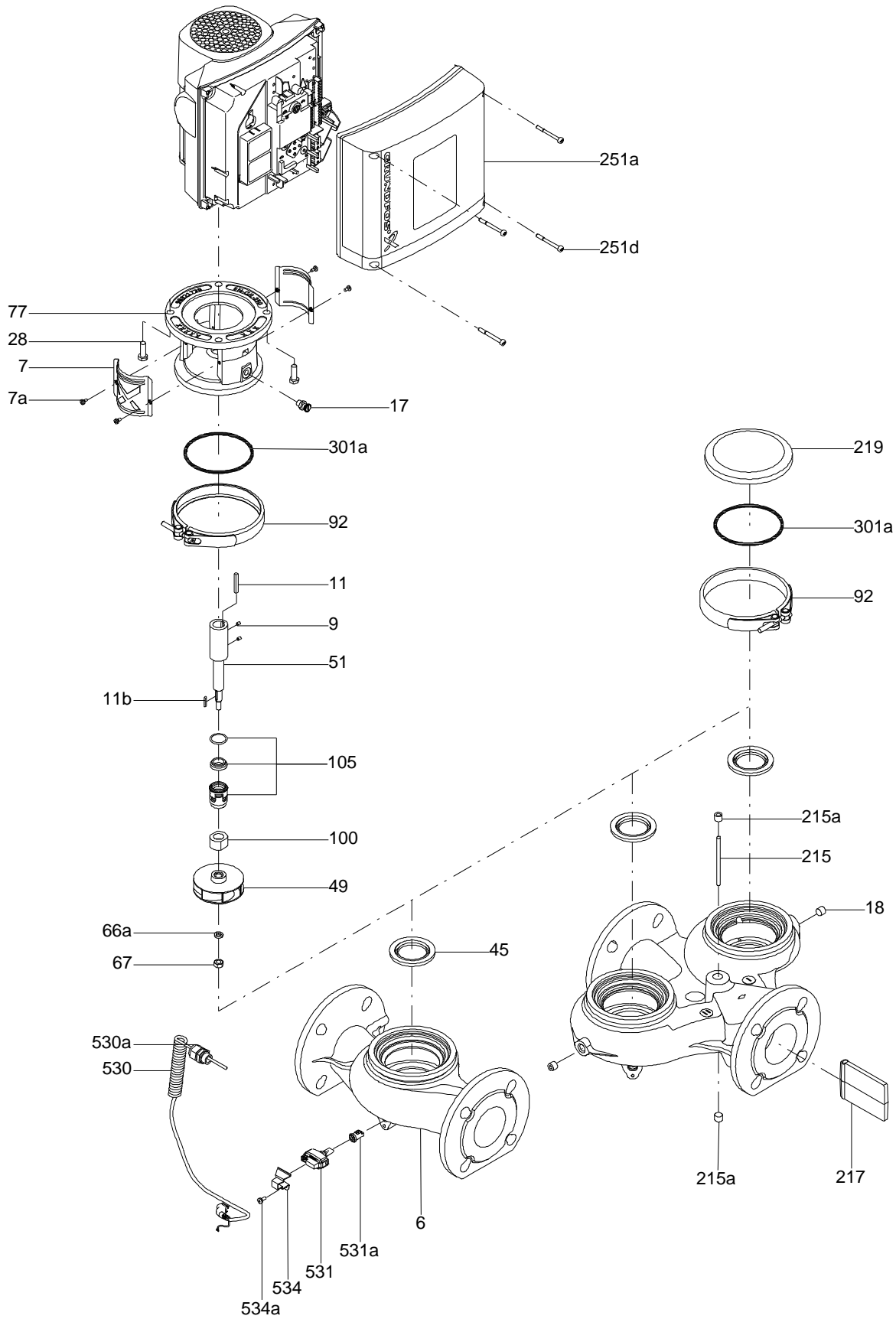

Sectional drawing (TM058200 for TPE2,TPE3)

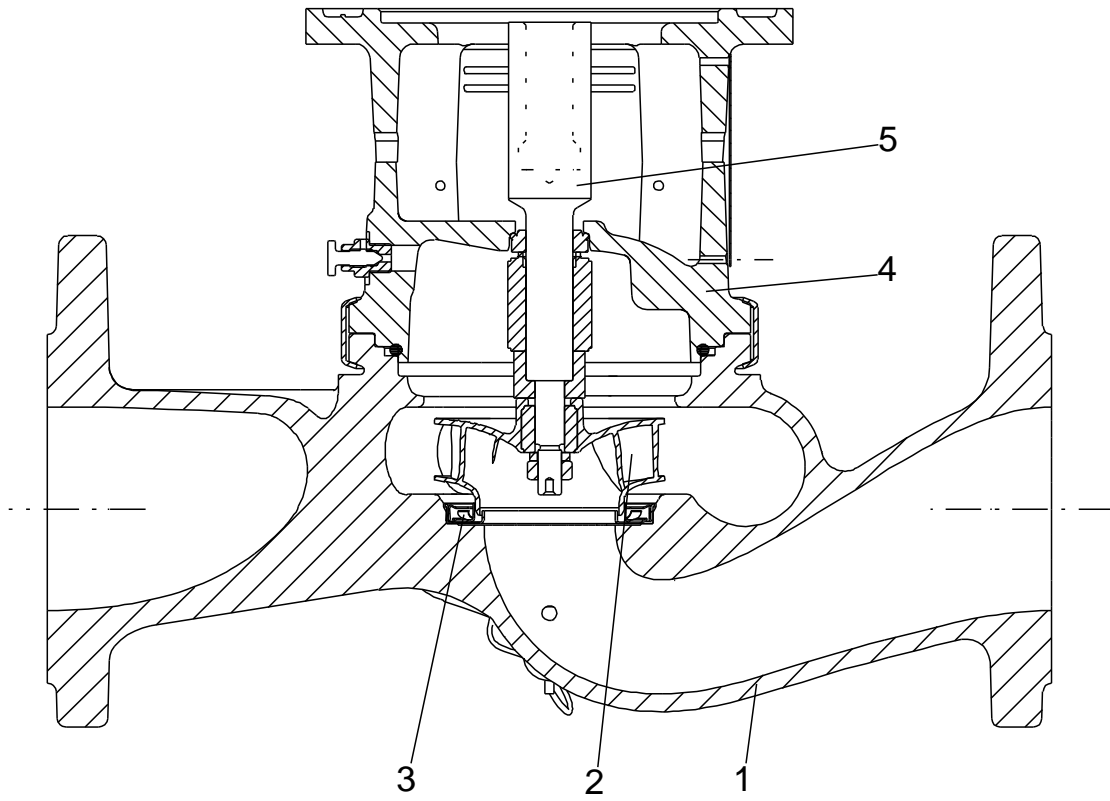

TM058200

Exploded view (TM057026 for MGE model H/I)

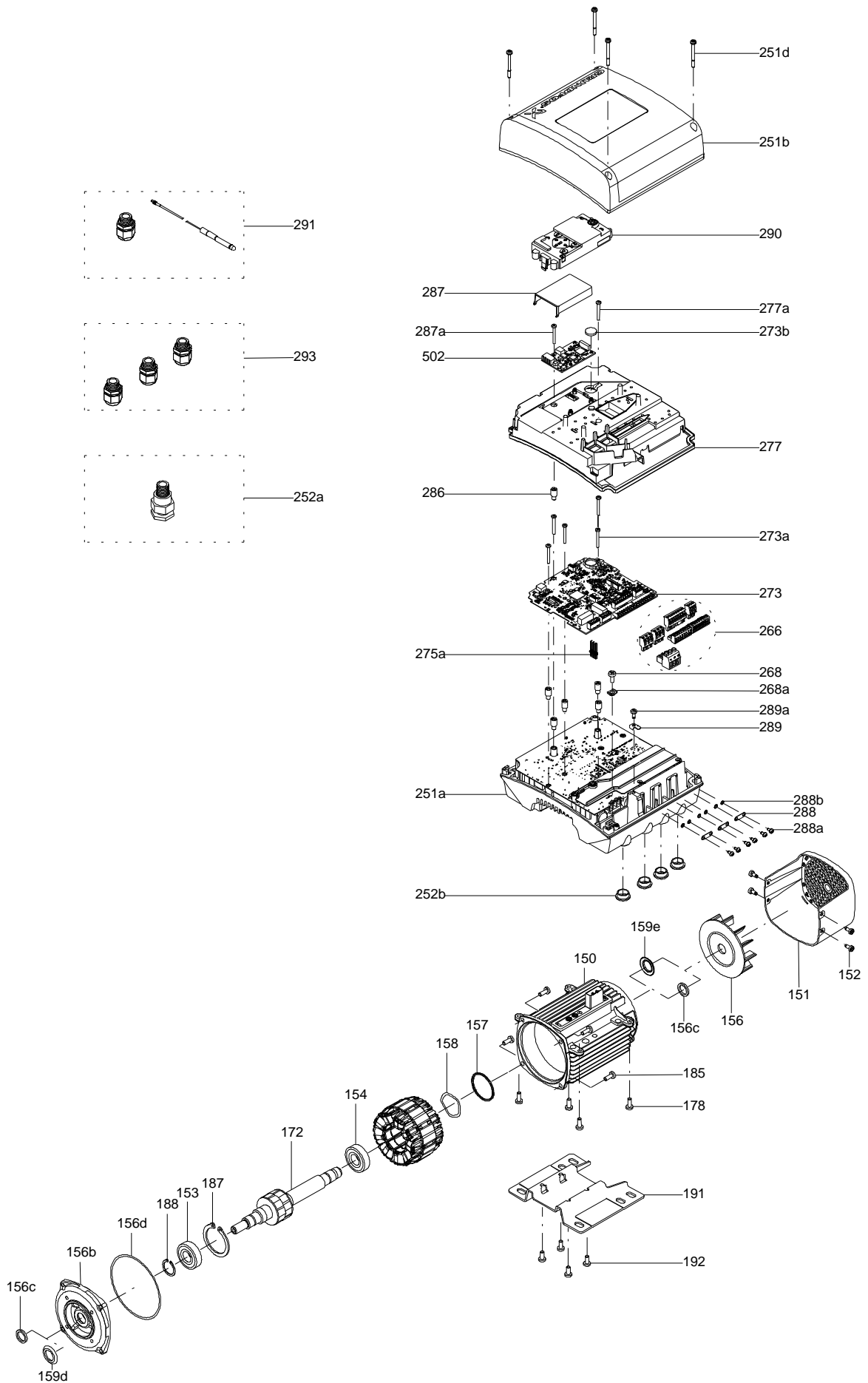

Parts list TP 32-30/4, Product No. On request
Valid from 20.6.2010 (1024)

Pos	Description	Annotation	Données de classification	Référence	Quantité	Unité
	Motor				1	pcs
-	Coupling cpl.				1	pcs
9	Hex socket head cap screw		Designation: DIN 912		4	
			Length (mm): 20			
			Thread: M6			
10	Shaft pin		Diameter: 5		1	
			Length (mm): 21,5			
10a	Coupling half				2	
-	Motor stool cpl.				1	pcs
2	Motor stool				1	
28	Hex head screw		Length (mm): 25		4	
			Thread: M8			
28	Hex head screw		Length (mm): 16 MM		4	
			Thread: M5			
-	Pump housing cpl.				1	pcs
- 6	Pump housing				1	
	Pump housing				1	
45	Neck ring				1	
-	Coupling guard cpl.				1	pcs
7	Coupling guard				2	
7a	Pan head screw				4	
66	Lock washer				4	
-	Shaft seal cpl.				1	pcs
105	Shaft seal				1	
-	Shaft w/impeller cpl.				1	pcs
48	Split cone nut				1	
49	Impeller cpl.				1	
49b	Split cone				1	
51	Shaft cpl.				1	
17	Air vent screw				1	pcs
19	Plug				2	pcs
72a	O-ring				1	pcs

Disclaimer: The information about the Grundfos pump in this document may be outdated.

Data may be subject to alterations without further notice.

Please contact us to verify the data above is still accurate/up-to-date.

All information is copyright Grundfos.



info@lenntech.com

<https://www.lenntech.com>

tel. +31 152 610 900

fax. +31 152 616 289