

TP 50-120/4-A-F-A-BAQE 1X230 50HZ
Grundfos pump 98760134



Thank you for your interest in our products. Please contact us for more information, or visit our website

<https://www.lenntech.com/grundfos/TP000/98760134/TP-50-120-4-A-F-A-BAQE.html>

info@lenntech.com

tel. +31 152 610 900

fax. +31 152 616 289

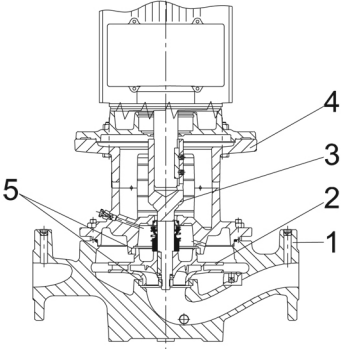
Position	Qty.	Description
	1	<p data-bbox="320 163 612 197">TP 50-120/4 A-F-A-BAQE</p>  <p data-bbox="320 483 600 517">Product No.: On request</p> <p data-bbox="320 544 1445 622">Single-stage, close-coupled, volute pump with in-line suction and discharge ports of identical diameter. The pump is of the top-pull-out design, i.e. the power head (motor, pump head and impeller) can be removed for maintenance or service while the pump housing remains in the pipework.</p> <p data-bbox="320 629 1422 685">The pump is fitted with an unbalanced rubber bellows seal. The shaft seal is according to EN 12756. Pipework connection is via PN 16 DIN flanges (EN 1092-2 and ISO 7005-2).</p> <p data-bbox="320 689 951 723">The pump is fitted with a fan-cooled asynchronous motor.</p> <p data-bbox="320 748 639 781">Further product details</p> <p data-bbox="320 786 1426 864">The product's minimum efficiency index (MEI) is greater or equal to 0.70. This is by the Commission Regulation (EU) considered as an indicative benchmark for best-performing water pump available on the market as from 1 January 2013.</p> <p data-bbox="320 898 403 931">Pump</p> <p data-bbox="320 936 1257 969">Pump housing and pump head are electrocoated to improve the corrosion resistance.</p> <p data-bbox="320 974 584 996">Electrocoating includes:</p> <ol data-bbox="320 1001 810 1115" style="list-style-type: none"> 1) Alkaline-based cleaning. 2) Pretreatment with zinc phosphate coating. 3) Cathodic electrocoating (epoxy). 4) Curing of paint film at 200-250 °C.  <ol data-bbox="320 1518 608 1666" style="list-style-type: none"> 1: Pump housing 2: Impeller 3: Stub shaft 4: Pump head/motor stool 5: Wear rings <p data-bbox="320 1697 1458 1753">The pump housing is provided with a replaceable brass neck ring to reduce the amount of liquid running from the outlet side of the impeller to the inlet side. The impeller is secured to the shaft with a nut.</p> <p data-bbox="320 1809 1442 1888">The pump is fitted with an unbalanced rubber bellows seal with torque transmission across the spring and around the bellows. Due to the bellows, the seal does not wear the shaft, and the axial movement is not prevented by deposits on the shaft.</p> <p data-bbox="320 1899 467 1921">Primary seal:</p> <ul data-bbox="355 1926 1091 1984" style="list-style-type: none"> • Rotating seal ring material: carbon graphite, metal-impregnated • Stationary seat material: silicon carbide (SiC) <p data-bbox="320 1989 1453 2067">This material pairing has a very good corrosion resistance and is especially suitable for water up to 120 °C. However, seal life will be reduced at temperatures above 90 °C. The material pairing is not recommended for liquids containing particles as this will result in heavy wear on the SiC face.</p> <p data-bbox="320 2072 986 2101">Secondary seal material: EPDM (ethylene-propylene rubber)</p>

Position	Qty.	Description
		<p>EPDM has excellent resistance to hot water. EPDM is not suitable for mineral oils.</p> <p>A circulation of liquid through the duct of the air vent screw ensures lubrication and cooling of the shaft seal.</p> <p>The flanges have tapplings for mounting of pressure gauges.</p> <p>The motor stool forms connection between the pump housing and the motor, and is equipped with a manual air vent screw for venting of the pump housing and the shaft seal chamber. The sealing between motor stool and pump housing is an O-ring.</p> <p>The central part of the motor stool is provided with guards for protection against the shaft and coupling. The pump shaft is fastened directly on the motor shaft with key and set screws.</p> <p>Motor</p> <p>The motor is a totally enclosed, fan-cooled motor with principal dimensions to IEC and DIN standards. Electrical tolerances comply with IEC 60034.</p> <p>The motor is flange-mounted with free-hole flange (FF). Motor-mounting designation in accordance with IEC 60034-7: IM B 5, IM V 1 (Code I) / IM 3001, IM 3011 (Code II).</p> <p>The motor has built-in thermal protection (PTO current and temperature sensors) in accordance with IEC 60034-11 and requires no further motor protection. The protection reacts to both slow- and quick-rising temperatures, e.g. constant overload and stalled conditions.</p> <p>As the thermal protection incorporates automatic reset, the motor must be connected in a way which ensures that the automatic reset cannot cause accidents.</p> <p>Technical data</p> <p>Liquid: Pumped liquid: Water Liquid temperature range: 0 .. 120 °C Liquid temperature during operation: 20 °C Density: 998.2 kg/m³</p> <p>Technical: Rated flow: 22.9 m³/h Rated head: 9.77 m Actual impeller diameter: 198 mm Primary shaft seal: BAQE Curve tolerance: ISO9906:2012 3B</p> <p>Materials: Pump housing: Cast iron EN-JL1040 ASTM A48-40 B Impeller: Cast iron EN-JL1030 ASTM A48-30 B</p> <p>Installation: Range of ambient temperature: -30 .. 40 °C Maximum operating pressure: 16 bar Flange standard: DIN Pipe connection: DN 50 Pump inlet: DN 50 Pump outlet: DN 50 Pressure rating: PN 16 (@): 440 mm Flange size for motor: FF165</p> <p>Electrical data: Motor type: 90LB Rated power - P2: 1.1 kW Power (P2) required by pump: 1.1 kW Mains frequency: 50 Hz</p>

Position	Qty.	Description
		<p>Rated voltage: 1 x 220-230 V</p> <p>Rated current: 7 A</p> <p>Starting current: 390 %</p> <p>Cos phi - power factor: 0.96</p> <p>Rated speed: 1420-1430 rpm</p> <p>Motor efficiency at full load: 75-76 %</p> <p>Number of poles: 4</p> <p>Enclosure class (IEC 34-5): 55 Dust/Jetting</p> <p>Insulation class (IEC 85): F</p> <p>Others:</p> <p>Minimum efficiency index, MEI : 0.7</p> <p>ErP status: EuP Standalone/Prod.</p> <p>Net weight: 67 kg</p> <p>Gross weight: 86 kg</p> <p>Shipping volume: 0.39 m³</p>

On request TP 50-120/4 A-F-A-BAQE 50 Hz

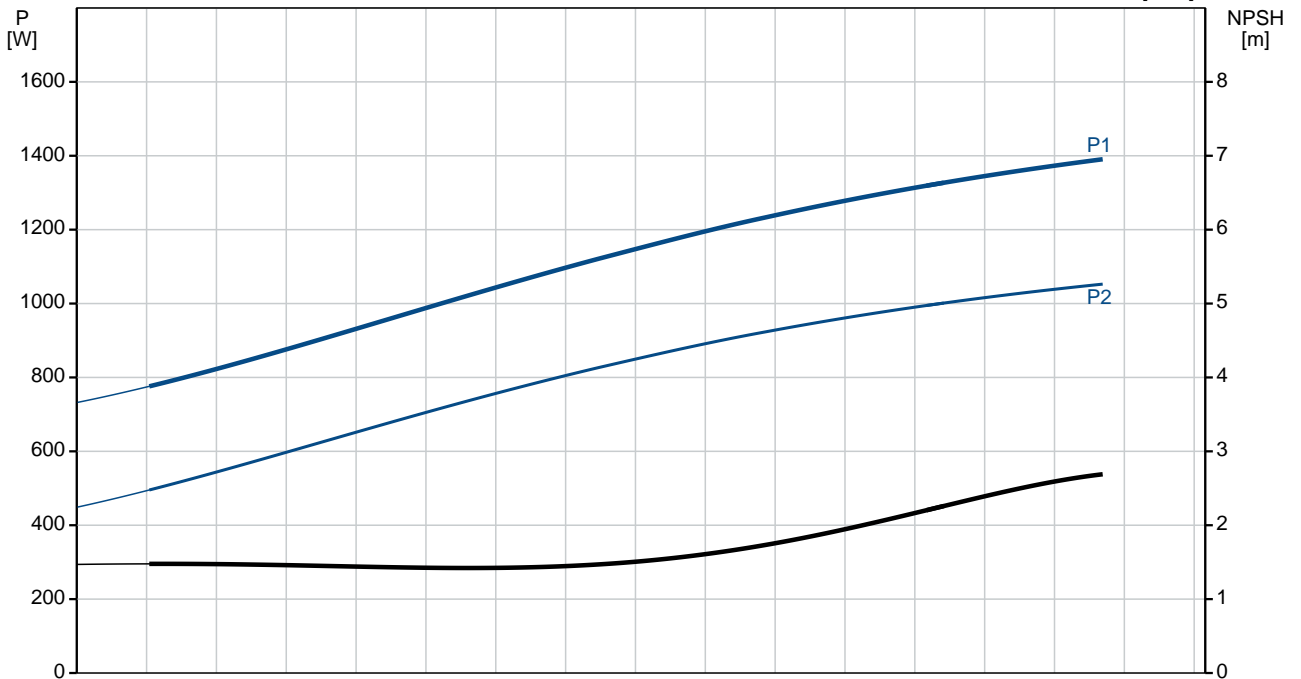
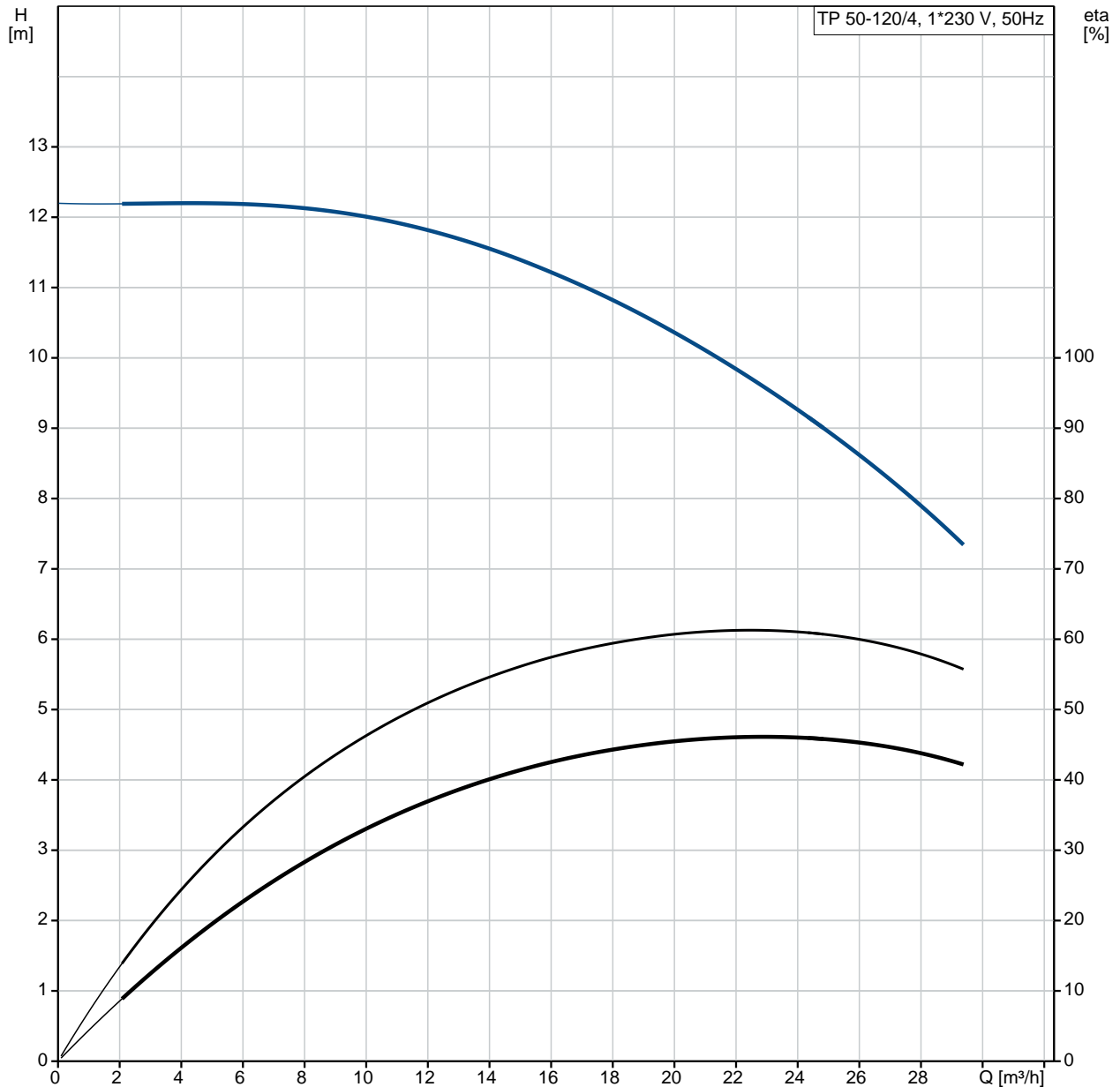

Description	Value
General information:	
Product name:	TP 50-120/4 A-F-A-BAQE
Product No:	On request
EAN number:	On request
Technical:	
Rated flow:	22.9 m ³ /h
Rated head:	9.77 m
Head max:	120 dm
Actual impeller diameter:	198 mm
Primary shaft seal:	BAQE
Curve tolerance:	ISO9906:2012 3B
Pump version:	A
Model:	A
Materials:	
Pump housing:	Cast iron EN-JL1040 ASTM A48-40 B
Impeller:	Cast iron EN-JL1030 ASTM A48-30 B
Material code:	A
Installation:	
Range of ambient temperature:	-30 .. 40 °C
Maximum operating pressure:	16 bar
Flange standard:	DIN
Pipe connection:	DN 50
Pump inlet:	DN 50
Pump outlet:	DN 50
Pressure rating:	PN 16
(@)	440 mm
Flange size for motor:	FF165
Connect code:	F
Liquid:	
Pumped liquid:	Water
Liquid temperature range:	0 .. 120 °C
Liquid temperature during operation:	20 °C
Density:	998.2 kg/m ³
Electrical data:	
Motor type:	90LB
Rated power - P2:	1.1 kW
Power (P2) required by pump:	1.1 kW
Mains frequency:	50 Hz
Rated voltage:	1 x 220-230 V
Rated current:	7 A
Starting current:	390 %
Cos phi - power factor:	0.96
Rated speed:	1420-1430 rpm
Motor efficiency at full load:	75-76 %
Number of poles:	4
Enclosure class (IEC 34-5):	55 Dust/Jetting
Insulation class (IEC 85):	F
Motor protec:	PTO
Motor No:	87200343
Others:	
Minimum efficiency index, MEI :	0.7
ErP status:	EuP Standalone/Prod.
Net weight:	67 kg
Gross weight:	86 kg
Shipping volume:	0.39 m ³

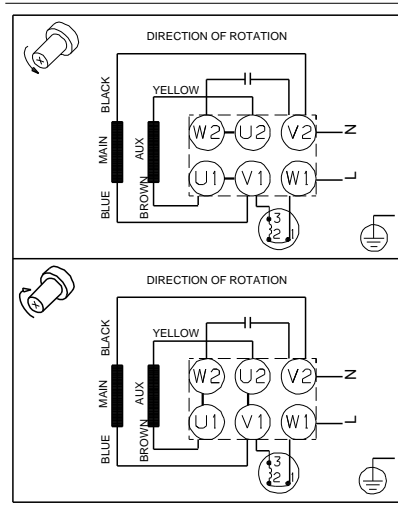
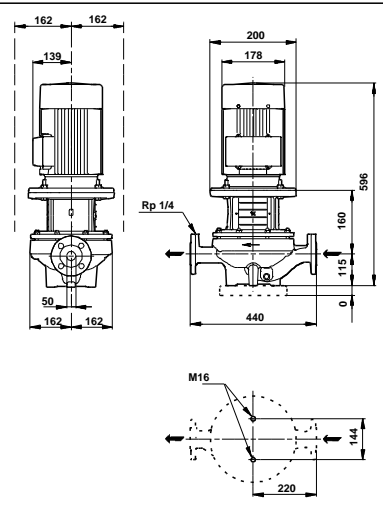
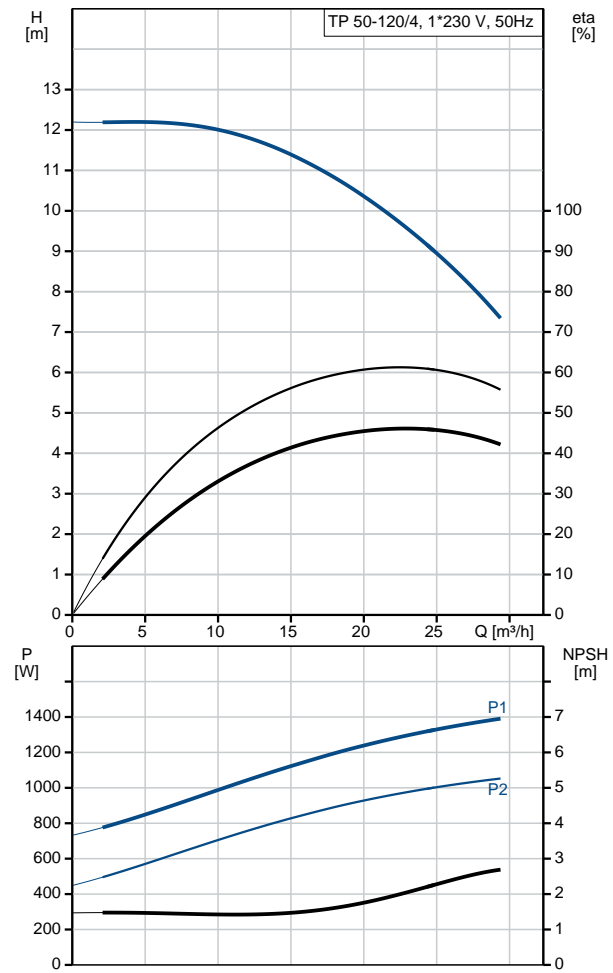

On request TP 50-120/4 A-F-A-BAQE 50 Hz

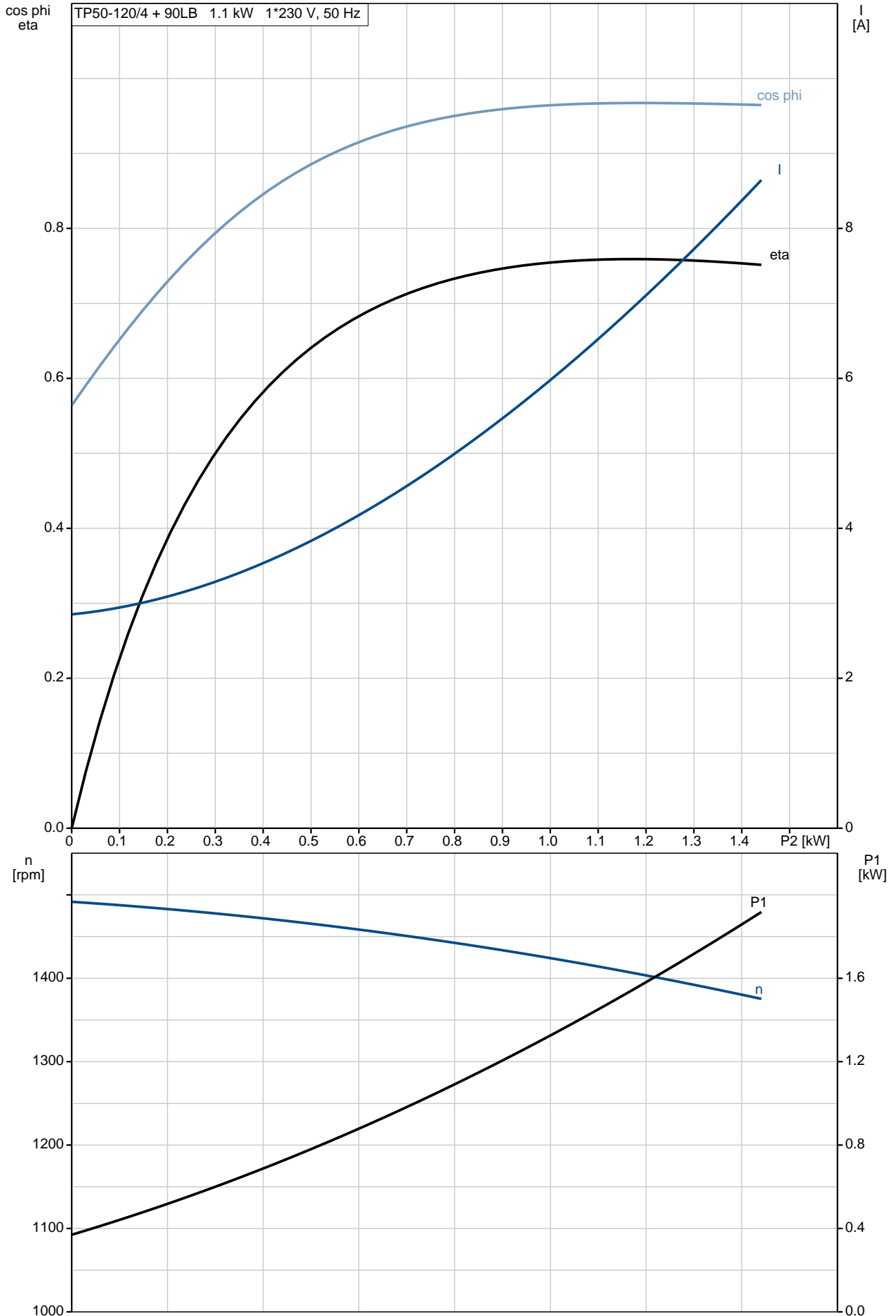

On request TP 50-120/4 A-F-A-BAQE 50 Hz

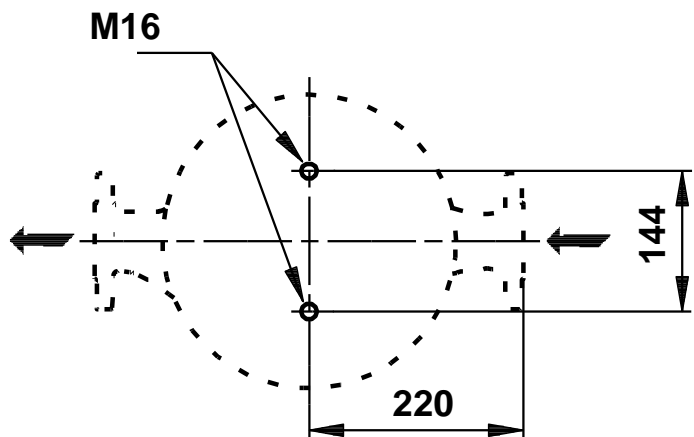
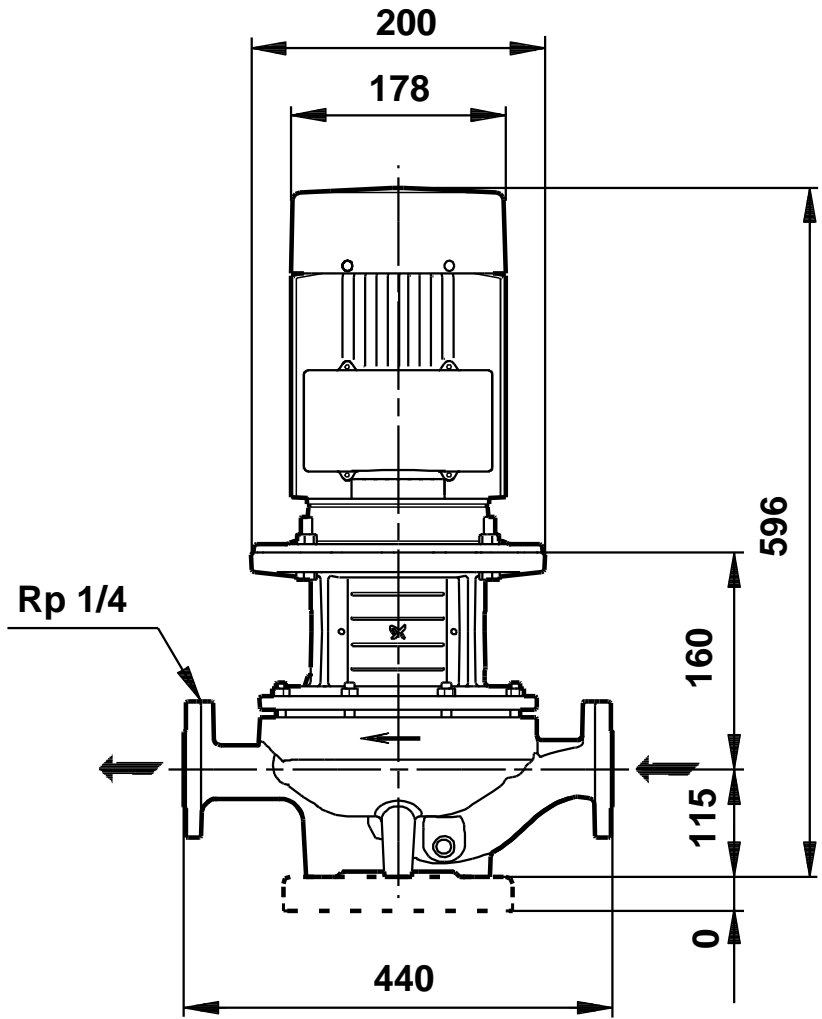
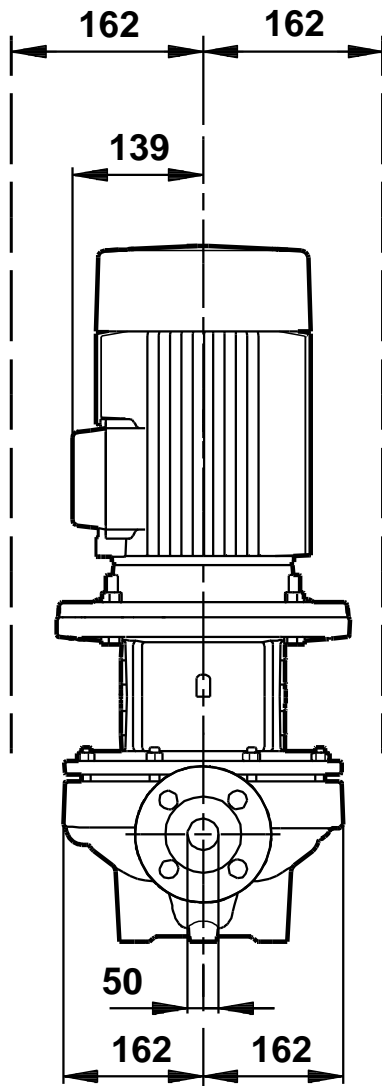

Note! All units are in [mm] unless others are stated.
Disclaimer: This simplified dimensional drawing does not show all details.

Exploded view

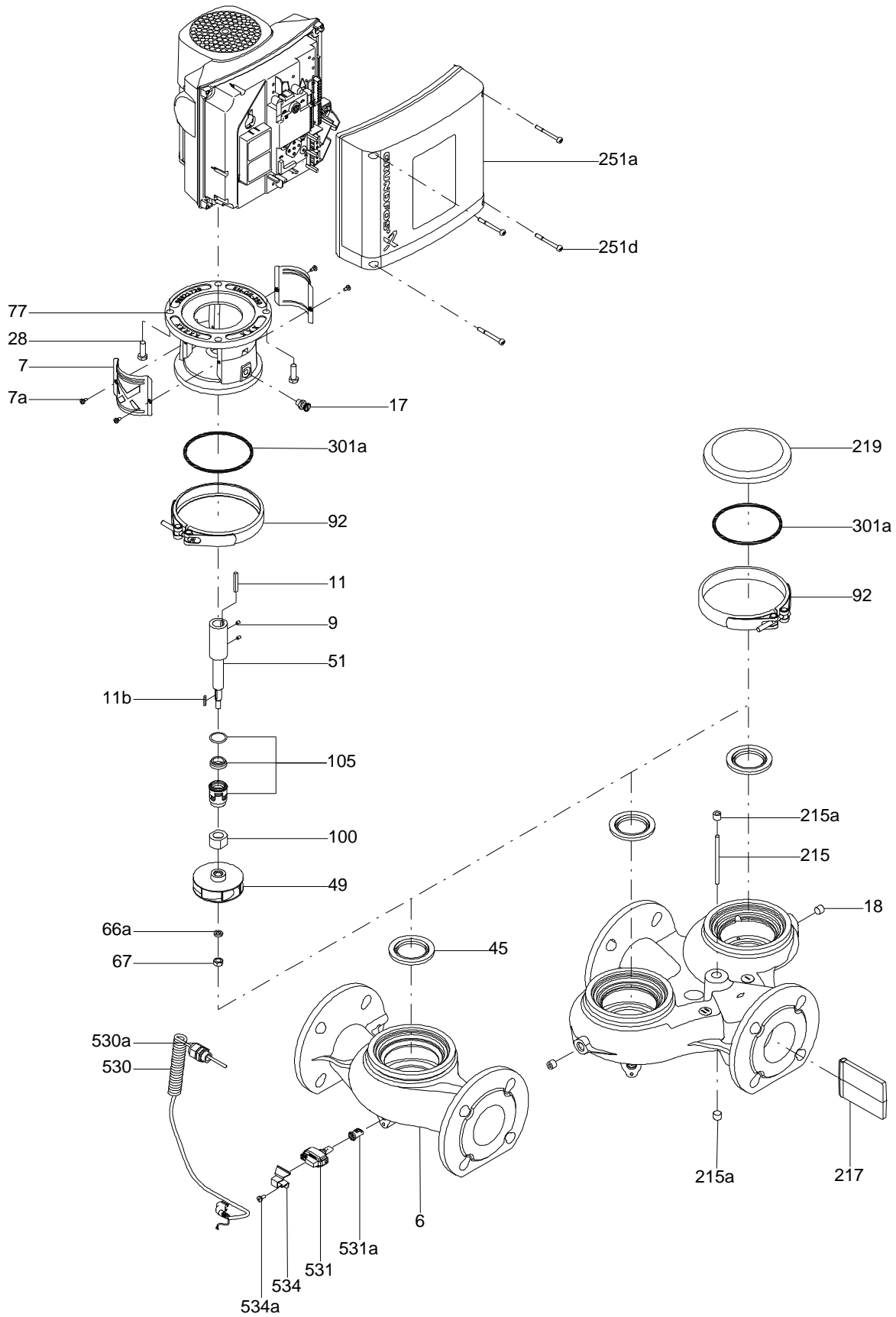

Sectional drawing (TM058200 for TPE2,TPE3)

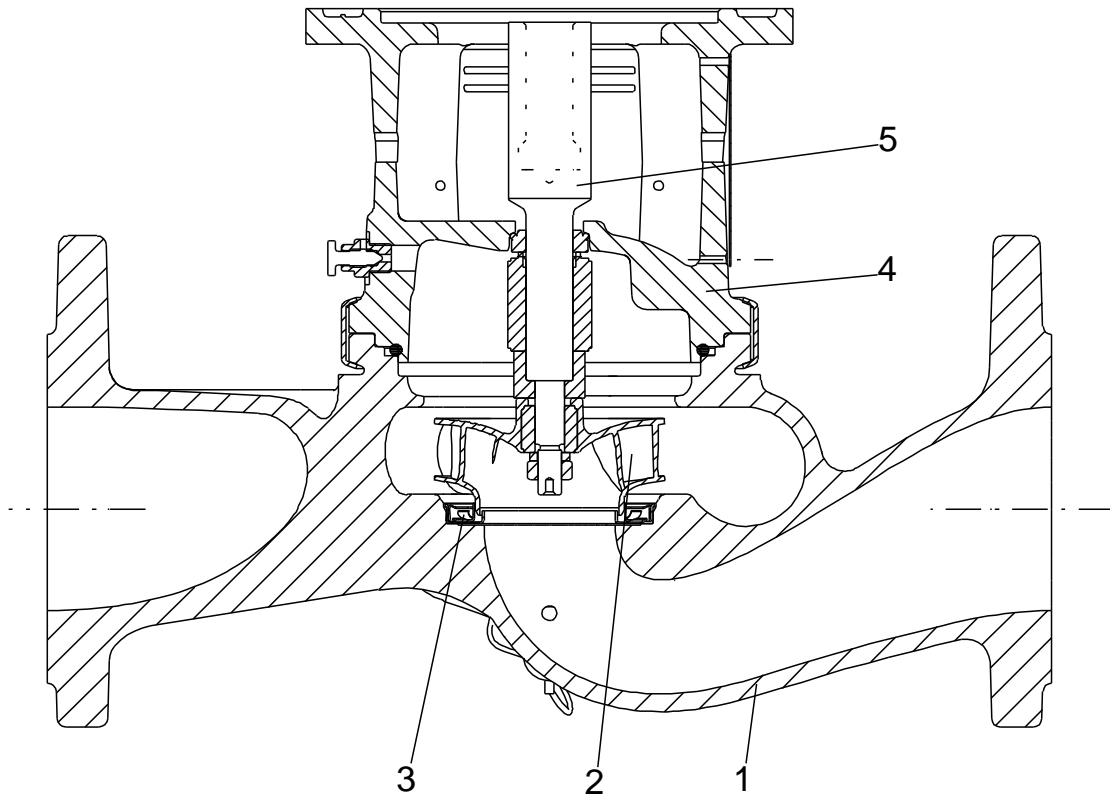

TM058200

Exploded view (TM057026 for MGE model H/I)

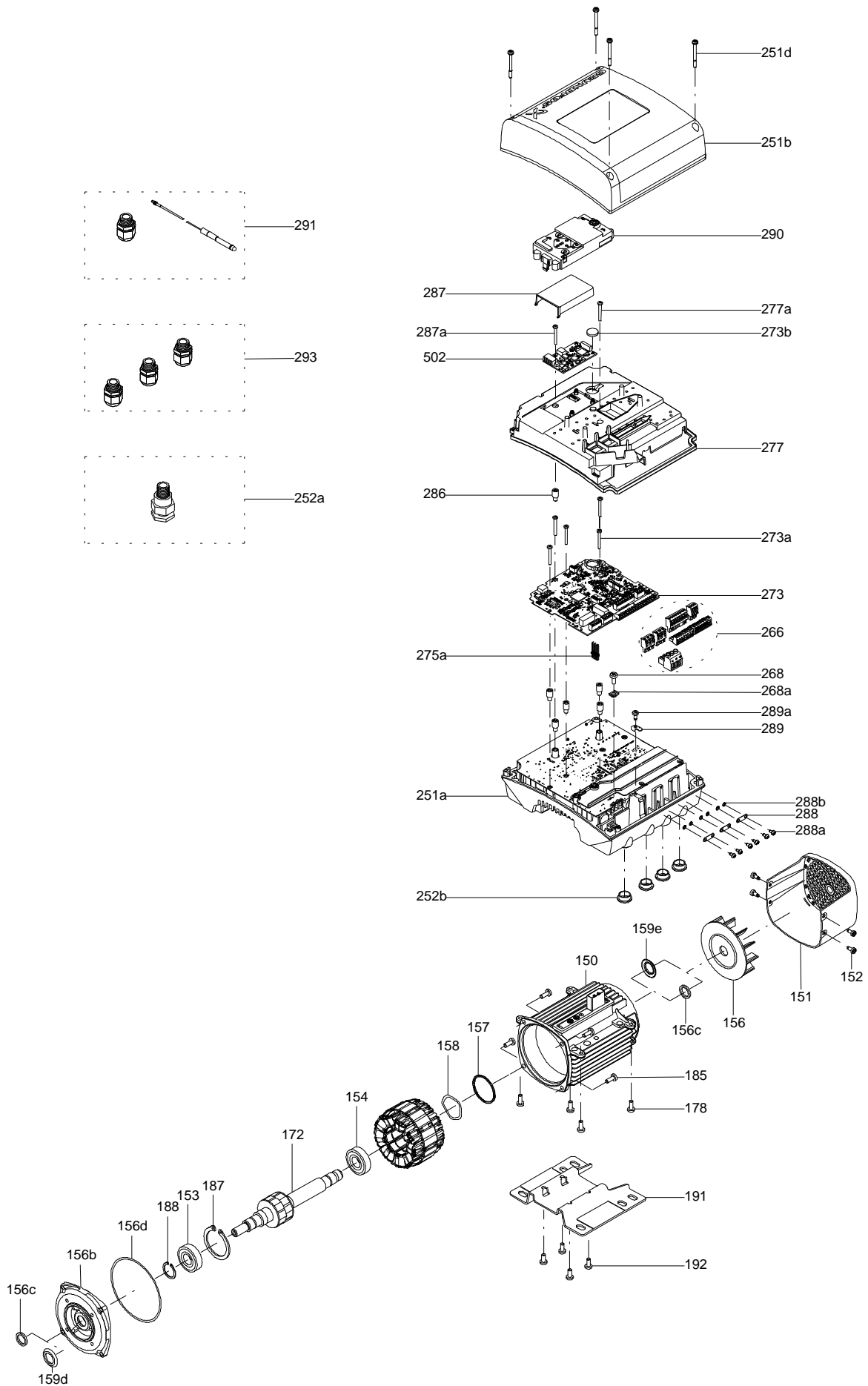

Parts list TP 50-120/4, Product No. On request
Valid from 20.6.2010 (1024)

Pos	Description	Annotation	Données de classification	Référence	Quantité	Unité
+	Motor				1	pcs
-	Nut				1	pcs
66	Washer				1	
66a	Spring lock washer				1	
67	Nut		Thread: M14		1	
-	Motor stool cpl.				1	pcs
2	Motor stool				1	
7	Coupling guard				2	
7a	Pan head screw				4	
9	Hex socket head cap screw		Length (mm): 30 Thread: M10		4	
-	Pump housing cpl.				1	pcs
6	Pump housing				1	
36	Nut		Thread: M10		10	
-	Shaft seal cpl.				1	pcs
72a	O-ring		Diameter: 253,6 Material type: EPDM Thickness: 3,53		1	
105	Shaft seal		Material type: BAQE		1	
-	Stub shaft				1	pcs
9	Socket set screw		Length (mm): 6 Thread: M8		2	
11	Parallel key		Dimension: 6X6X35		1	
51	Pump shaft				1	
17	Air vent screw				1	pcs
19	Plug				2	pcs
49	Impeller				1	pcs

Disclaimer: The information about the Grundfos pump in this document may be outdated.

Data may be subject to alterations without further notice.

Please contact us to verify the data above is still accurate/up-to-date.

All information is copyright Grundfos.



info@lenntech.com

<https://www.lenntech.com>

tel. +31 152 610 900

fax. +31 152 616 289