

CM5-5 S-R-I-E-AQQE C-A-A-N

Grundfos pump 98482181





Thank you for your interest in our products. Please contact us for more information, or visit our website

<https://www.lenntech.com/grundfos/CMSP0/98482181/CM5-5-S-R-I-E-AQQE.html>

info@lenntech.com

tel. +31 152 610 900

fax. +31 152 616 289

Position	Qty.	Description
	1	<p data-bbox="320 165 568 197">CM5-5 S-R-I-E-AQQE</p>  <p data-bbox="320 488 600 519">Product No.: On request</p> <p data-bbox="320 546 1453 674">Compact, reliable, horizontal, multistage, end-suction centrifugal pump with axial suction port and radial discharge port. The pump is self-priming and can create a suction lift of up to 4 m metres. Pump materials in contact with the liquid are in stainless steel. The mechanical shaft seal is a special designed, unbalanced O-ring seal. Pipework connection is via internal Whitworth pipe threads, Rp (ISO 7/1).</p> <p data-bbox="320 712 1214 743">The pump is fitted with a 1-phase, foot-mounted, fan-cooled asynchronous motor.</p> <p data-bbox="320 801 639 833">Further product details</p> <p data-bbox="320 842 1445 893">Pump and motor are integrated in a compact and user-friendly design. The pump is fitted to a low base plate, making it ideal for installation in systems where compactness is important.</p> <p data-bbox="320 898 1126 929">The pump can create a suction lift of 4 m metres in less than five minutes.</p> <p data-bbox="320 934 1434 985">Compared to other self-priming pumps, the CM pump offers lower noise level, higher reliability as well as compactness and customised solutions.</p> <p data-bbox="320 990 1294 1041">The pump is made of stainless-steel components (EN 1.4301 / AISI 304) and is therefore corrosion-proof.</p> <p data-bbox="320 1046 1382 1097">The state-of-the-art design and materials of the shaft seal ensure high wear resistance, improved sticking and dry-running capabilities and long operating life.</p> <p data-bbox="320 1102 1426 1153">Servicing the pump requires no special service tools. Service parts are in stock for quick delivery and are available as kits, single parts or bulk. Service videos are available on www.youtube.com.</p> <p data-bbox="320 1189 400 1220">Pump</p> <p data-bbox="320 1229 1458 1328">A combination of a stop ring and a Nord-lock® washer secures a tight and reliable fixation of the impeller spacing pipes to the splined pump shaft. It is possible to remove and fit the hydraulic parts from the pump side. The inlet and outlet port are integrated in the pump sleeve. The inlet part, chambers and discharge part are hold together by four staybolts and a retaining flange.</p> <p data-bbox="320 1366 1458 1417">The pump is fitted with an unbalanced O-ring seal with a rigid torque-transmission system. It has a fixed seal driver ensuring a reliable rotation of all parts. The dynamic secondary seal is an O-ring.</p> <p data-bbox="320 1422 464 1453">Primary seal:</p> <ul data-bbox="357 1458 919 1509" style="list-style-type: none"> • Rotating seal ring material: silicon carbide (SiC) • Stationary seat material: silicon carbide (SiC) <p data-bbox="320 1514 1426 1565">This material pairing is used where higher corrosion resistance is required. The high hardness of this material pairing offers good resistance against abrasive particles.</p> <p data-bbox="320 1570 983 1601">Secondary seal material: EPDM (ethylene-propylene rubber)</p> <p data-bbox="320 1606 1214 1637">EPDM has excellent resistance to hot water. EPDM is not suitable for mineral oils.</p>  <p data-bbox="320 1850 1430 1901">The pump shaft is connected to the motor shaft through a left thread and tight fit. The shaft cannot be dismantled.</p> <p data-bbox="320 1937 400 1968">Motor</p> <p data-bbox="320 1977 1398 2029">The motor is a totally enclosed, fan-cooled motor with principal dimensions to EN 50347. Electrical tolerances comply with EN 60034.</p>

The motor has built-in thermal protection (PTO current and temperature sensors) in accordance with IEC 60034-11 and requires no further motor protection. The protection reacts to both slow- and quick-rising temperatures, e.g. constant overload and stalled conditions.

As the thermal protection incorporates automatic reset, the motor must be connected in a way which ensures that the automatic reset cannot cause accidents.

Technical data

Liquid:

Pumped liquid: Water
Liquid temperature range: 0 .. 60 °C
Liquid temperature during operation: 20 °C
Density: 998.2 kg/m³

Technical:

Rated flow: 4.7 m³/h
Rated head: 38 m
Primary shaft seal: AQQE
Approvals on nameplate: CE,WRAS,ACS,TR,EAC
Curve tolerance: ISO9906:2012 3B
Self-priming: 4 m

Materials:

Pump housing: Stainless steel
DIN W.-Nr. 1.4301
AISI 304
Impeller: Stainless steel
DIN W.-Nr. 1.4301
AISI 304
Rubber: EPDM

Installation:

Maximum ambient temperature: 55 °C
Maximum operating pressure: 10 bar
Max pressure at stated temp: 10 bar / 60 °C
Flange standard: WHITWORTH THREAD RP
Pump inlet: Rp 1
Pump outlet: Rp 1

Electrical data:

Motor type: 80B
Rated power - P2: 0.9 kW
Mains frequency: 50 Hz
Rated voltage: 1 x 220-240 V
Service factor: 1
Rated current: 5.4-5.0 A
Starting current: 430 %
Rated speed: 2750-2790 rpm
Enclosure class (IEC 34-5): IP55
Insulation class (IEC 85): F

Others:

Minimum efficiency index, MEI : 0.7
Net weight: 17 kg
Gross weight: 19.5 kg

On request CM5-5 S-R-I-E-AQQE 50 Hz

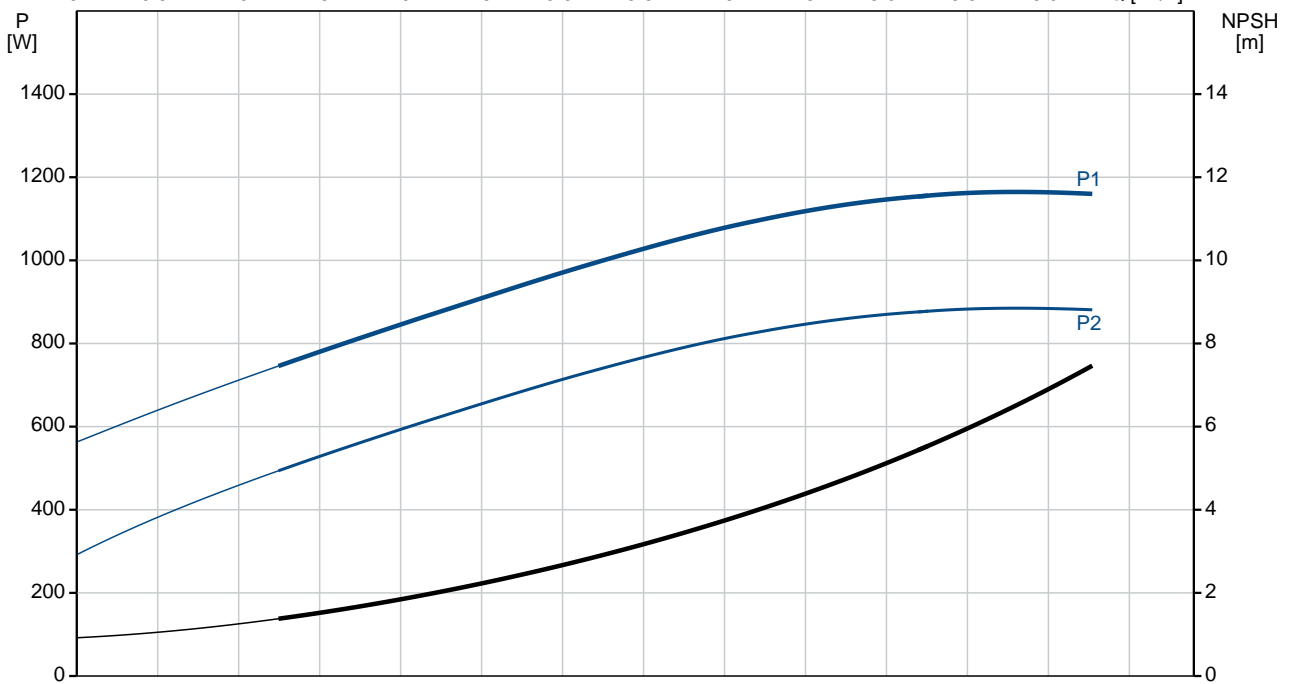
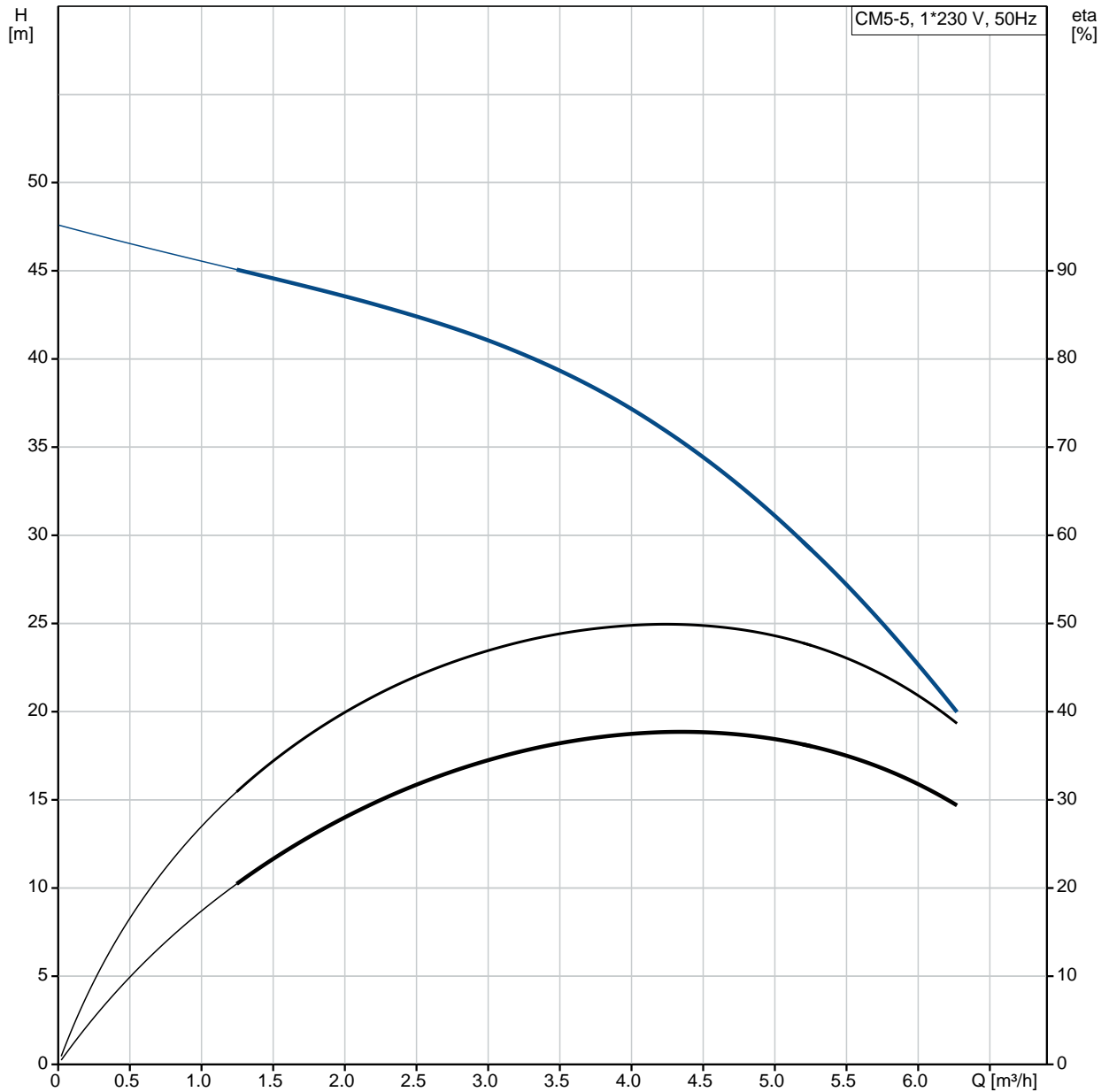

Description	Value
-------------	-------

General information:
 Product name: CM5-5 S-R-I-E-AQQE
 Product No: On request
 EAN number: On request

Technical:
 Rated flow: 4.7 m³/h
 Rated head: 38 m
 Impellers: 5
 Primary shaft seal: AQQE
 Approvals on nameplate: CE,WRAS,ACS,TR,EAC
 Curve tolerance: ISO9906:2012 3B
 Pump version: S
 Model: A
 Self-priming: 4 m

Materials:
 Pump housing: Stainless steel
 DIN W.-Nr. 1.4301
 AISI 304
 Impeller: Stainless steel
 DIN W.-Nr. 1.4301
 AISI 304

Material code: I
 Rubber: EPDM
 Code for rubber: E

Installation:
 Maximum ambient temperature: 55 °C
 Maximum operating pressure: 10 bar
 Max pressure at stated temp: 10 bar / 60 °C
 Flange standard: WHITWORTH THREAD RP
 Pump inlet: Rp 1
 Pump outlet: Rp 1
 Connect code: R

Liquid:
 Pumped liquid: Water
 Liquid temperature range: 0 .. 60 °C
 Liquid temperature during operation: 20 °C
 Density: 998.2 kg/m³

Electrical data:
 Motor type: 80B
 Rated power - P2: 0.9 kW
 Mains frequency: 50 Hz
 Rated voltage: 1 x 220-240 V
 Service factor: 1
 Rated current: 5.4-5.0 A
 Starting current: 430 %
 Rated speed: 2750-2790 rpm
 Enclosure class (IEC 34-5): IP55
 Insulation class (IEC 85): F
 Motor protec: TP211

Others:
 Minimum efficiency index, MEI : 0.7
 Net weight: 17 kg
 Gross weight: 19.5 kg

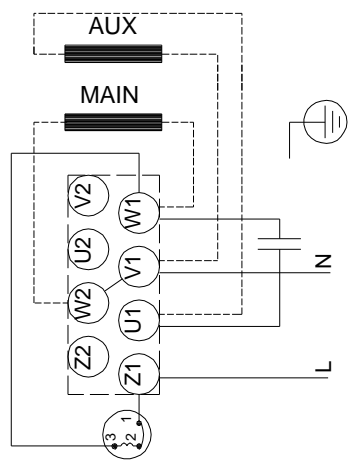
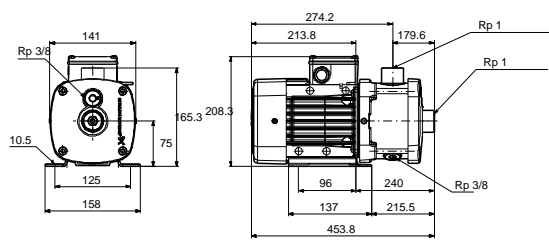
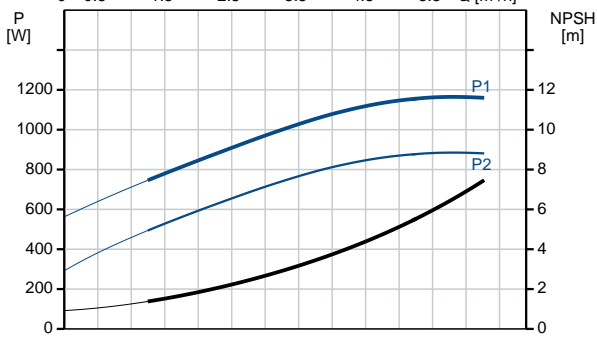
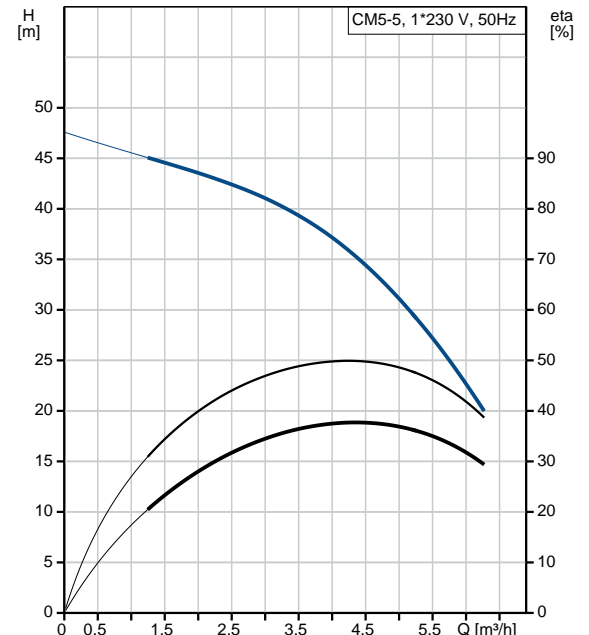

On request CM5-5 S-R-I-E-AQQE 50 Hz

CM5-5 + 80B 0.9 kW 1*230 V, 50 Hz, SF = 1

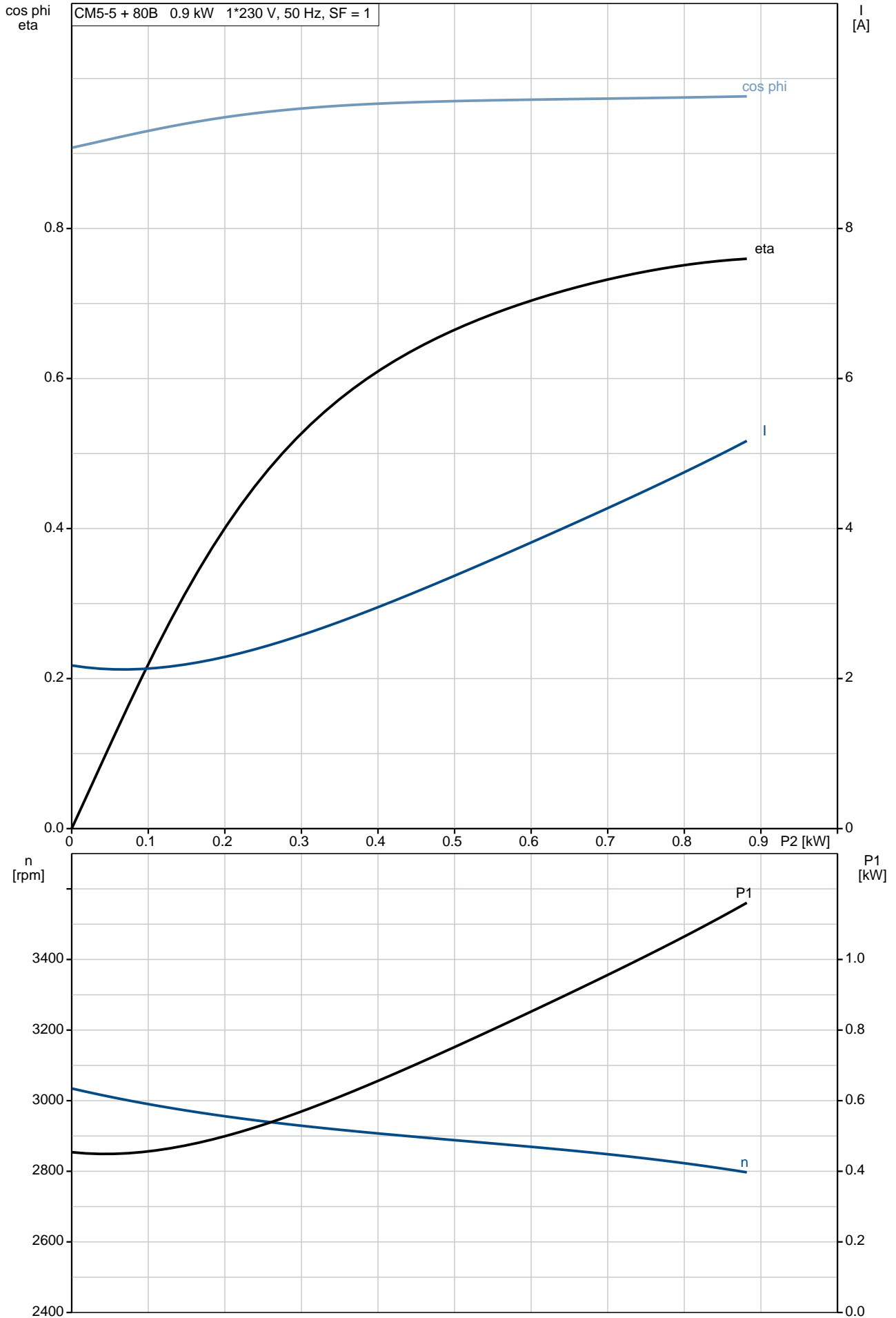

On request CM5-5 S-R-I-E-AQQE 50 Hz

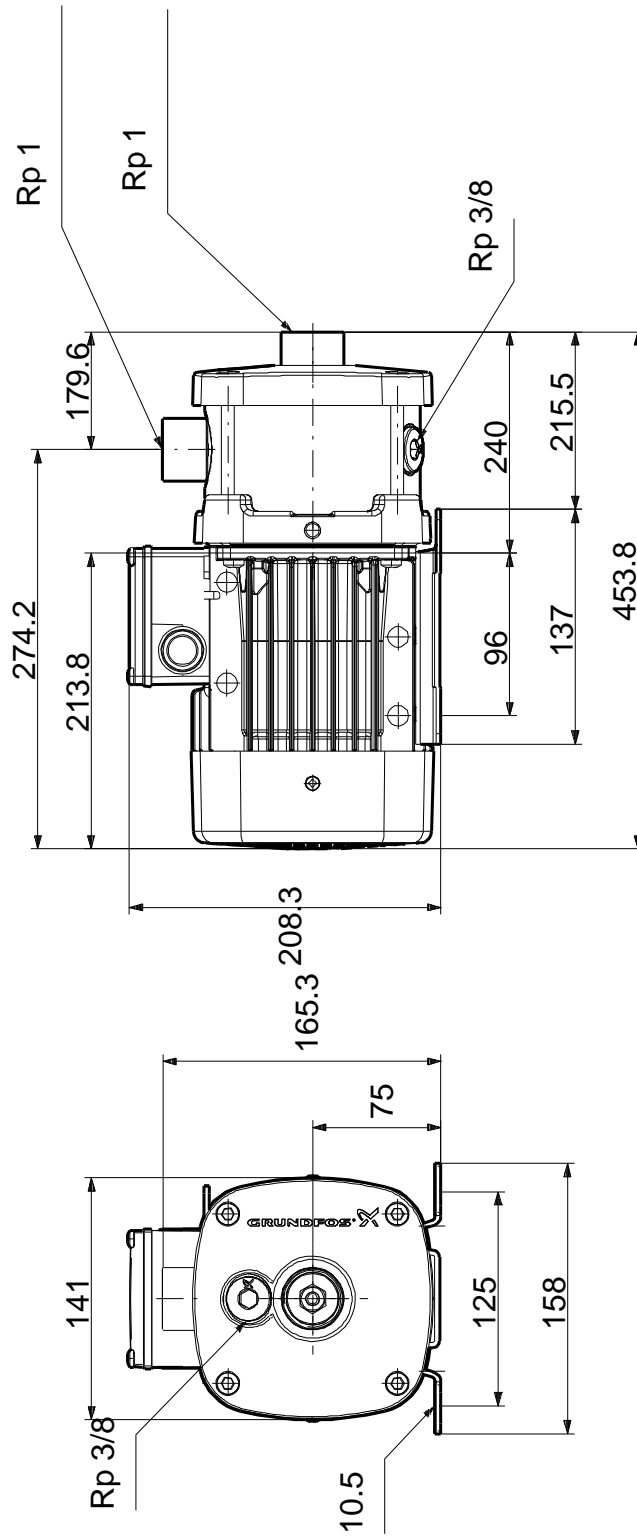

Note! All units are in [mm] unless others are stated.
 Disclaimer: This simplified dimensional drawing does not show all details.

Exploded view

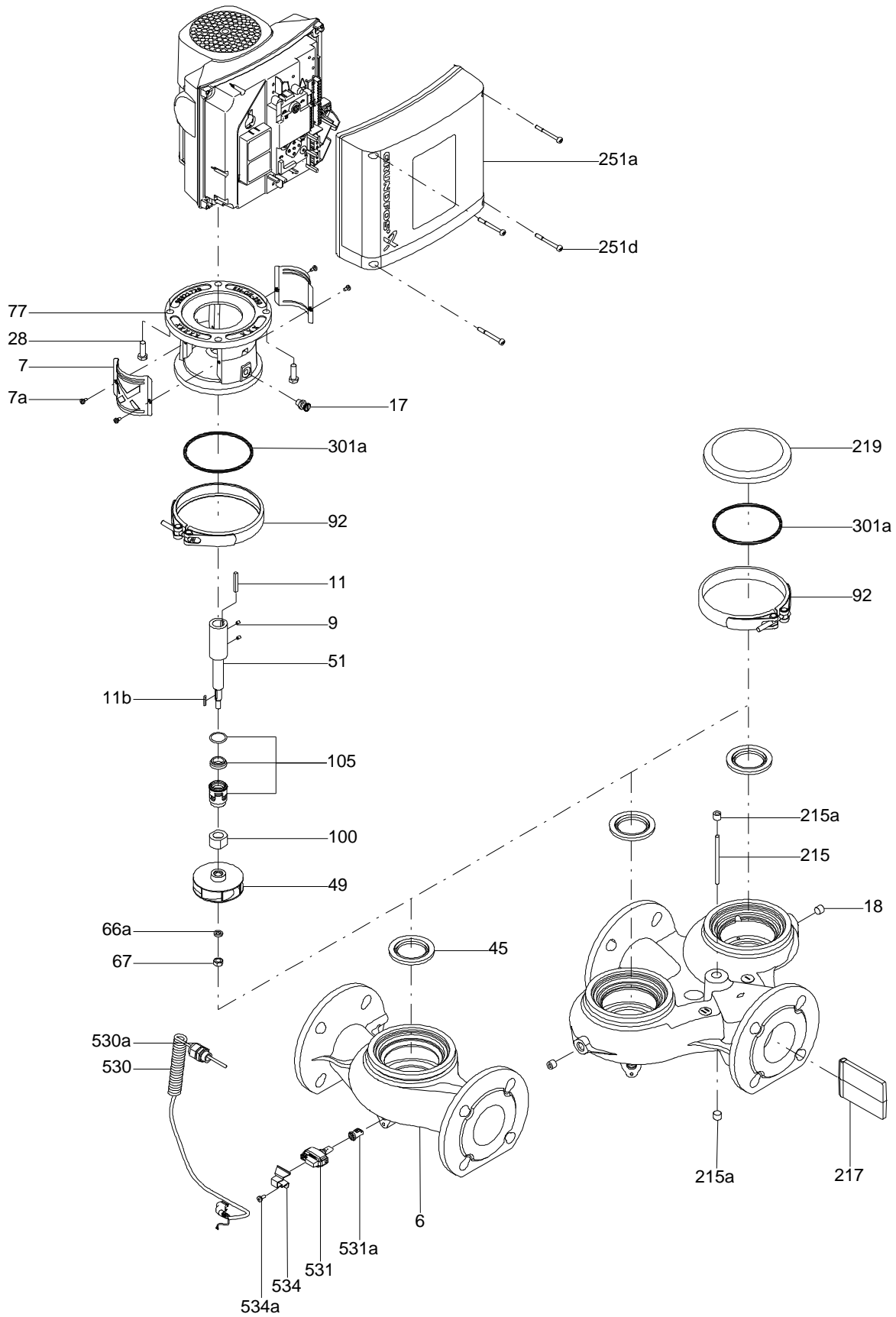

Sectional drawing (TM058200 for TPE2,TPE3)

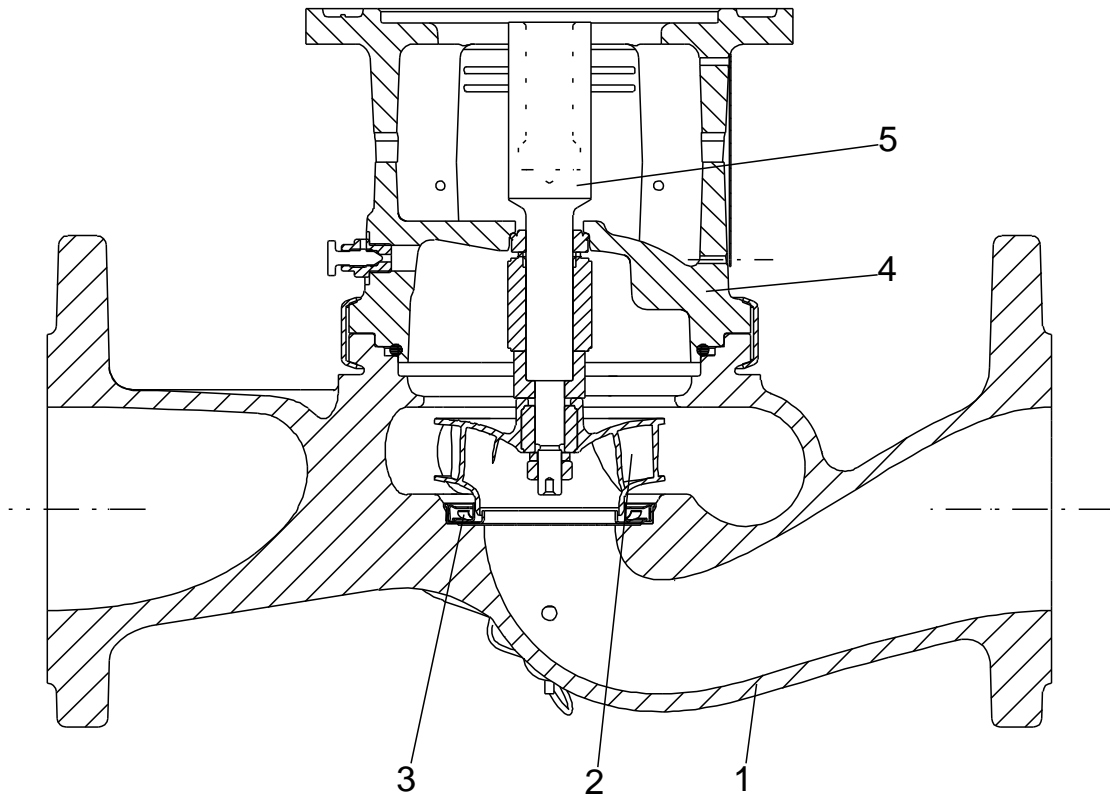

TM058200

Exploded view (TM057026 for MGE model H/I)

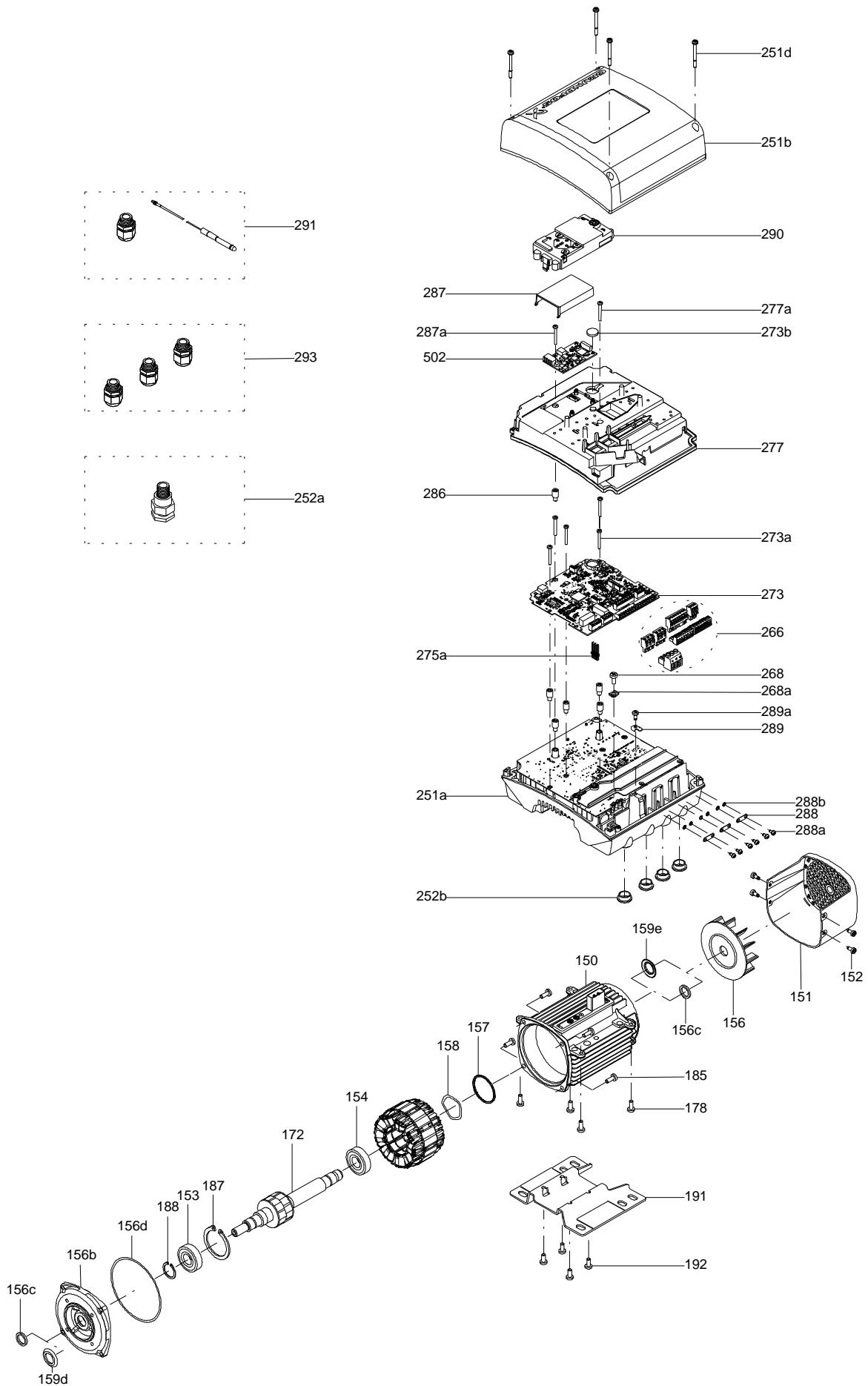

Parts list CM5-5, Product No. On request
Valid from 10.9.2013 (1337)

Pos	Description	Annotation	Données de classification	Référence	Quantité	Unité
-	Chamber cpl.				1	pcs
4e	Chamber				1	
5d	Base				1	
5e	Spring				1	
-	Container				1	pcs
64f	Rubber seal				1	
64g	Container				1	
-	MG80B				1	pcs
	Jumper				1	
	Protector cpl.				1	
alt. 1.1	Stator				1	
alt. 1.2	Stator				1	
28	Pan head screw				4	
51	Shaft w/rotor				1	
79	Gasket				1	
150	Stator housing				1	
152	Pan head thread forming screw				4	
154	Ball bearing				1	
154	Ball bearing		Designation: 6204.2Z.C3.SYN		1	
155	Bearing cover				1	
156b	Motor flange				1	
156d	Gasket		Internal diameter: 114,80 Outer diameter: 121,20 Thickness: 0,25		1	
158	Waved washer				1	
158.a	O-ring				1	
159	O-ring		Diameter: 32 Material type: NBR Thickness: 2		1	
159a	Seal ring				1	
164	Terminal box cover w/gasket				1	
164a	Terminal box w/gasket				1	
166	Pan head screw				4	
173	Pan head thread forming screw		Designation: COMBI TORX T25		1	
173a	Base				1	
176	Terminal				1	
	Cross recess countersunk screw				4	pcs
- 4	Chamber cpl.				4	pcs
	Guide vane				6	
	Plate				1	
	Retainer				1	
	Intermediate chamber				1	
	Vane				1	
45	Neck ring				1	
65	Retainer				1	
- 4d	Chamber cpl.				1	pcs
	Chamber cpl.				1	
	Guide plate				1	
4f	Chamber, empty				2	pcs
5b	Water trap				1	pcs
5c	O-ring				1	pcs
6.a	Flange				1	pcs
16	Collar sleeve cpl.				1	pcs
- 25	Drain plug cpl.				2	pcs
11	O-ring		Diameter: 18,5 Material type: EPDM Thickness: 2		1	
25	Plug				1	
26	Hex socket head cap screw		Length (mm): 185		4	pcs

Pos	Description	Annotation	Données de classification	Référence	Quantité	Unité
31	O-ring		Thread: M8 Diameter: 114 Material type: EPDM Thickness: 3,9		1	pcs
- 32	Cover plate				1	pcs
	Cover plate				1	
	Plate				1	
36	Lock nut		Thread: M8		1	pcs
49	Impeller cpl.				4	pcs
51	Pump shaft		Diameter: D12		1	pcs
64	Spacing pipe				3	pcs
64.c	Clamp				1	pcs
64a	Spacing pipe		Length (mm): 13.00		1	pcs
66	Wedge lock washer				1	pcs
76	Nameplate				2	pcs
- 105	Shaft seal				1	pcs
102	O-ring		Diameter: 17,86 Material type: EPDM Thickness: 2,62		1	
103	Seal ring, stationary				1	
104	Seal ring, rotating				1	
107	O-ring				1	
108	Compression spring				1	
111	Retainer				1	
112	Driver for shaft seal				1	
111.a	Stop ring				1	pcs
151	Fan cover				1	pcs
152	Pan head thread forming screw				2	pcs
156	Fan				1	pcs
191	Base plate				1	pcs

Disclaimer: The information about the Grundfos pump in this document may be outdated.

Data may be subject to alterations without further notice.

Please contact us to verify the data above is still accurate/up-to-date.

All information is copyright Grundfos.



info@lenntech.com

<https://www.lenntech.com>

tel. +31 152 610 900

fax. +31 152 616 289