

CME3-2 A-R-G-E-AQQE U-A-D-N

Grundfos pump 98394777



Thank you for your interest in our products. Please contact us for more information, or visit our website

<https://www.lenntech.com/grundfos/CMEBASIS/98394777/CME3-2-A-R-G-E-AQQE.html>

info@lenntech.com

tel. +31 152 610 900

fax. +31 152 616 289

Position	Qty.	Description
	1	<p data-bbox="320 163 596 192">CME3-2 A-R-G-E-AQQE</p>  <p data-bbox="320 483 600 512">Product No.: On request</p> <p data-bbox="320 544 1453 645">Compact, reliable, horizontal, multistage, end-suction centrifugal pump with axial suction port and radial discharge port. Pump materials in contact with the liquid are in high-grade stainless steel. The mechanical shaft seal is a special designed, unbalanced O-ring seal. Pipework connection is via internal Whitworth pipe threads, Rp (ISO 7/1).</p> <p data-bbox="320 685 1390 739">The pump is fitted with a 1-phase, fan-cooled, permanent-magnet, synchronous motor. The motor efficiency is classified as IE5 in accordance with IEC 60034-30-2.</p> <p data-bbox="320 743 1453 819">The motor includes a frequency converter and PI controller in the motor terminal box. This enables continuously variable control of the motor speed, which again enables adaptation of the performance to a given requirement.</p> <p data-bbox="320 860 1437 936">An operating panel on the motor terminal box enables setting of required setpoint as well as setting of pump to "Min." or "Max." operation or to "Stop". The Grundfos Eye indicator on the operating panel provides visual indication of pump status:</p> <ul data-bbox="357 945 1437 1088" style="list-style-type: none"> • "Power on": Motor is running (rotating green indicator lights) or not running (permanently green indicator lights) • "Warning": Motor is still running (rotating yellow indicator lights) or has stopped (permanently yellow indicator lights) • "Alarm": Motor has stopped (flashing red indicator lights). <p data-bbox="320 1120 1445 1196">Communication with the pump is possible by means of Grundfos GO Remote (accessory). The remote control enables further settings as well as reading out of a number of parameters such as "Actual value", "Speed", "Power input" and total "Power consumption".</p> <p data-bbox="320 1263 927 1292">The terminal box holds terminals for these connections:</p> <ul data-bbox="357 1296 1015 1561" style="list-style-type: none"> • one dedicated digital input • two analog inputs, 0(4)-20 mA, 0-5 V, 0-10 V, 0.5 - 3.5 V • 5 V voltage supply to potentiometer and sensor • one configurable digital input or open-collector output • Grundfos Digital Sensor input and output • 24 V voltage supply for sensors • two signal-relay outputs (potential-free contacts) • GENIbus connection • interface for Grundfos CIM fieldbus module. <p data-bbox="320 1621 639 1650">Further product details</p> <p data-bbox="320 1657 1445 1711">Pump and motor are integrated in a compact and user-friendly design. The pump is fitted to a low base plate, making it ideal for installation in systems where compactness is important.</p> <p data-bbox="320 1715 1382 1769">The state-of-the-art design and materials of the shaft seal ensure high wear resistance, improved sticking and dry-running capabilities and long operating life.</p> <p data-bbox="320 1774 1430 1827">Servicing the pump requires no special service tools. Service parts are in stock for quick delivery and are available as kits, single parts or bulk. Service videos are available on www.youtube.com.</p> <p data-bbox="320 1859 903 1888">Frequency converter operation offers these functions:</p> <ul data-bbox="357 1892 927 1977" style="list-style-type: none"> - controlled operation, i.e. consumption fluctuates - constant pressure - communication with the pump. <p data-bbox="320 2009 1342 2038">Adaption of performance through frequency-controlled speed offers obvious benefits such as:</p> <ul data-bbox="357 2042 596 2096" style="list-style-type: none"> - energy savings - increased comfort

Position	Qty.	Description
		<p>- control and monitoring of the application and pump performance.</p> <p>An operating panel on the motor terminal box enables setting of required setpoint as well as setting of pump to "Min." or "Max." operation or to "Stop". The Grundfos Eye indicator on the operating panel provides visual indication of pump status:</p> <ul style="list-style-type: none"> • "Power on": Motor is running (rotating green indicator lights) or not running (permanently green indicator lights) • "Warning": Motor is still running (rotating yellow indicator lights) or has stopped (permanently yellow indicator lights) • "Alarm": Motor has stopped (flashing red indicator lights). <p>Communication with the pump is possible by means of Grundfos GO Remote (accessory). The remote control enables further settings as well as reading out of a number of parameters such as "Actual value", "Speed", "Power input" and total "Power consumption".</p> <p>Pump</p> <p>A combination of a stop ring and a Nord-lock® washer secures a tight and reliable fixation of the impeller spacing pipes to the splined pump shaft. It is possible to remove and fit the hydraulic parts from the pump side. The inlet and outlet port are integrated in the pump sleeve. The inlet part, chambers and discharge part are hold together by four staybolts and a retaining flange.</p> <p>The pump is fitted with an unbalanced O-ring seal with a rigid torque-transmission system. It has a fixed seal driver ensuring a reliable rotation of all parts. The dynamic secondary seal is an O-ring.</p> <p>Primary seal:</p> <ul style="list-style-type: none"> • Rotating seal ring material: silicon carbide (SiC) • Stationary seat material: silicon carbide (SiC) <p>This material pairing is used where higher corrosion resistance is required. The high hardness of this material pairing offers good resistance against abrasive particles.</p> <p>Secondary seal material: EPDM (ethylene-propylene rubber) EPDM has excellent resistance to hot water. EPDM is not suitable for mineral oils.</p>  <p>The pump shaft is connected to the motor shaft through a left thread and tight fit. The shaft cannot be dismantled.</p> <p>Motor</p> <p>The motor is a totally enclosed, fan-cooled motor with principal dimensions to EN 50347. Electrical tolerances comply with EN 60034.</p> <p>The motor efficiency is classified as IE5 in accordance with IEC 60034-30-2. The motor requires no external motor protection. The motor control unit incorporates protection against slow- and quick-rising temperatures, e.g. constant overload and stalled conditions.</p> <p>The terminal box holds terminals for these connections:</p> <ul style="list-style-type: none"> • one dedicated digital input • two analog inputs, 0(4)-20 mA, 0-5 V, 0-10 V, 0.5 - 3.5 V • 5 V voltage supply to potentiometer and sensor • one configurable digital input or open-collector output • Grundfos Digital Sensor input and output • 24 V voltage supply for sensors • two signal-relay outputs (potential-free contacts) • GENIbus connection • interface for Grundfos CIM fieldbus module. <p>Technical data</p> <p>Liquid: Pumped liquid: Water Liquid temperature range: -20 .. 120 °C</p>

Position	Qty.	Description
		<p>Liquid temperature during operation: 20 °C Density: 998.2 kg/m³</p> <p>Technical: Rated flow: 3.7 m³/h Rated head: 19.1 m Primary shaft seal: AQQE Approvals on nameplate: CE,TR,CURUS,EAC Curve tolerance: ISO9906:2012 3B</p> <p>Materials: Pump housing: Stainless steel DIN W.-Nr. 1.4401 AISI 316 Impeller: Stainless steel DIN W.-Nr. 1.4401 AISI 316 Rubber: EPDM</p> <p>Installation: Maximum ambient temperature: 40 °C Maximum operating pressure: 16 bar Max pressure at stated temp: 10 bar / 120 °C 16 bar / 90 °C Flange standard: WHITWORTH THREAD RP Pump inlet: Rp 1 Pump outlet: Rp 1</p> <p>Electrical data: Motor type: 71A IE Efficiency class: IE5 Rated power - P2: 0.55 kW Mains frequency: 50 Hz Rated voltage: 1 x 200-240 V Rated current: 3.45-2.90 A Rated speed: 360-4000 rpm Enclosure class (IEC 34-5): IP55 Insulation class (IEC 85): F</p> <p>Others: Minimum efficiency index, MEI : 0.7 Net weight: 13.5 kg Gross weight: 17 kg</p>

On request CME3-2 A-R-G-E-AQQE 50 Hz

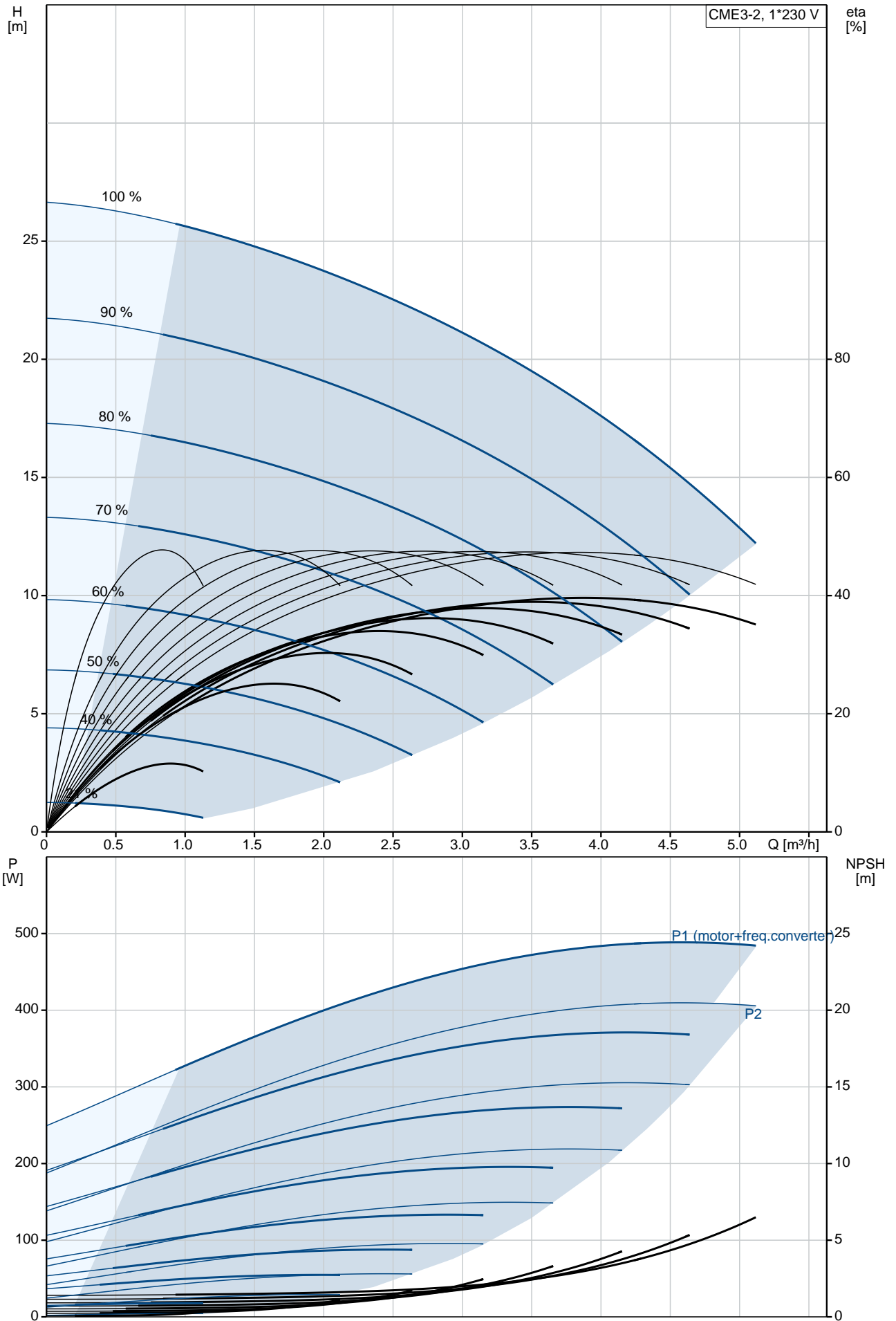

Description	Value
General information:	
Product name:	CME3-2 A-R-G-E-AQQE
Product No:	On request
EAN number:	On request
Technical:	
Rated flow:	3.7 m ³ /h
Rated head:	19.1 m
Impellers:	2
Primary shaft seal:	AQQE
Approvals on nameplate:	CE,TR,CURUS,EAC
Curve tolerance:	ISO9906:2012 3B
Pump version:	A
Model:	A
Materials:	
Pump housing:	Stainless steel DIN W.-Nr. 1.4401 AISI 316
Impeller:	Stainless steel DIN W.-Nr. 1.4401 AISI 316
Material code:	G
Rubber:	EPDM
Code for rubber:	E
Installation:	
Maximum ambient temperature:	40 °C
Maximum operating pressure:	16 bar
Max pressure at stated temp:	10 bar / 120 °C 16 bar / 90 °C
Flange standard:	WHITWORTH THREAD RP
Pump inlet:	Rp 1
Pump outlet:	Rp 1
Connect code:	R
Liquid:	
Pumped liquid:	Water
Liquid temperature range:	-20 .. 120 °C
Liquid temperature during operation:	20 °C
Density:	998.2 kg/m ³
Electrical data:	
Motor type:	71A
IE Efficiency class:	IE5
Rated power - P2:	0.55 kW
Mains frequency:	50 Hz
Rated voltage:	1 x 200-240 V
Rated current:	3.45-2.90 A
Rated speed:	360-4000 rpm
Enclosure class (IEC 34-5):	IP55
Insulation class (IEC 85):	F
Others:	
Minimum efficiency index, MEI :	0.7
Net weight:	13.5 kg
Gross weight:	17 kg
Config. file no:	98498682

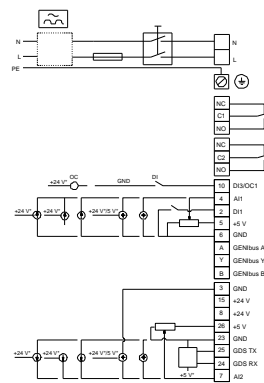
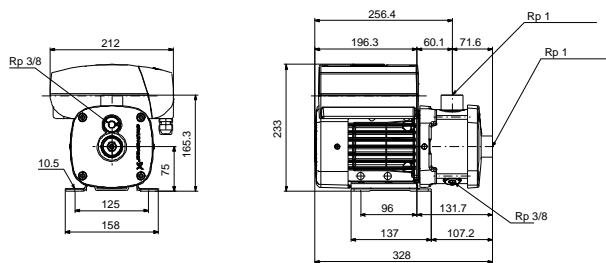
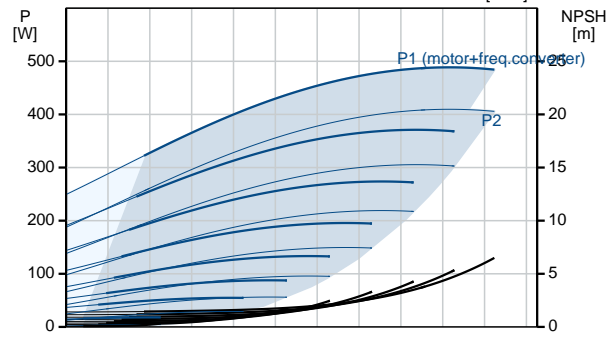
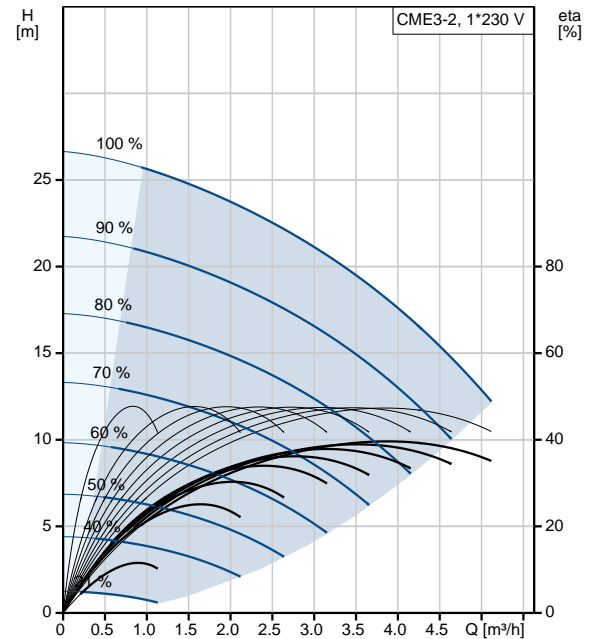

On request CME3-2 A-R-G-E-AQQE 50 Hz

CME3-2 + 71A 0.55 kW 1*230 V, 50 Hz

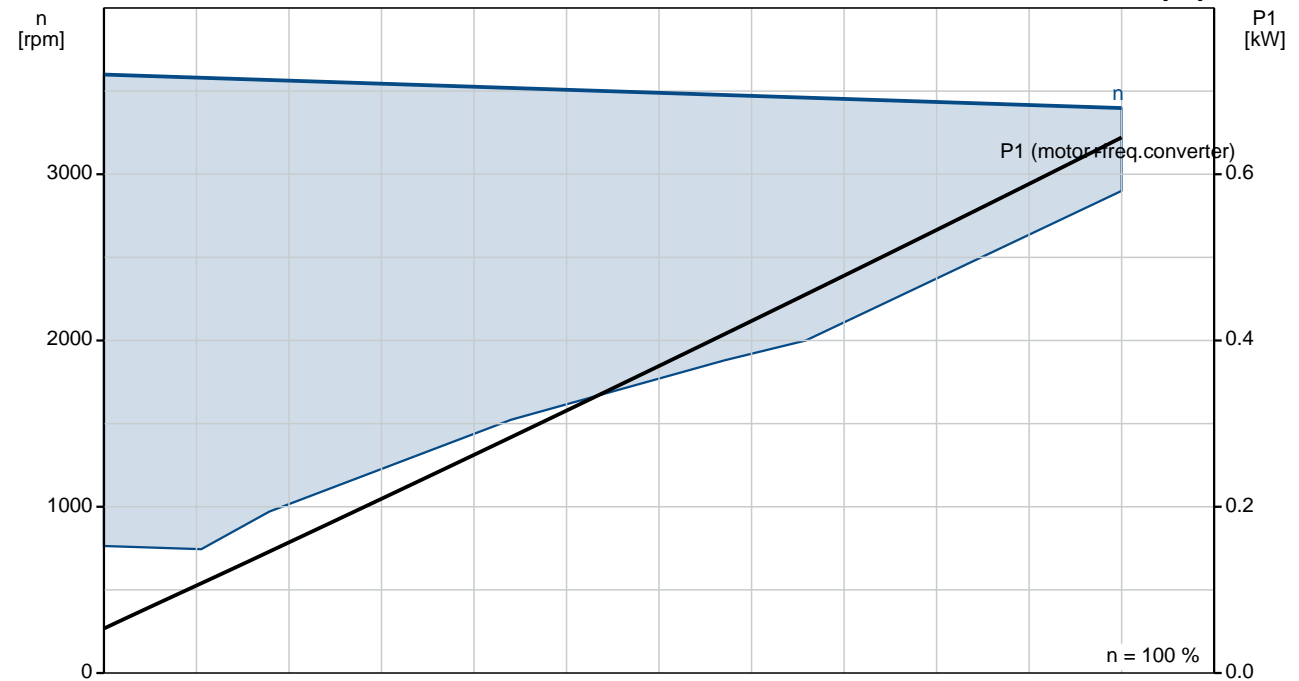
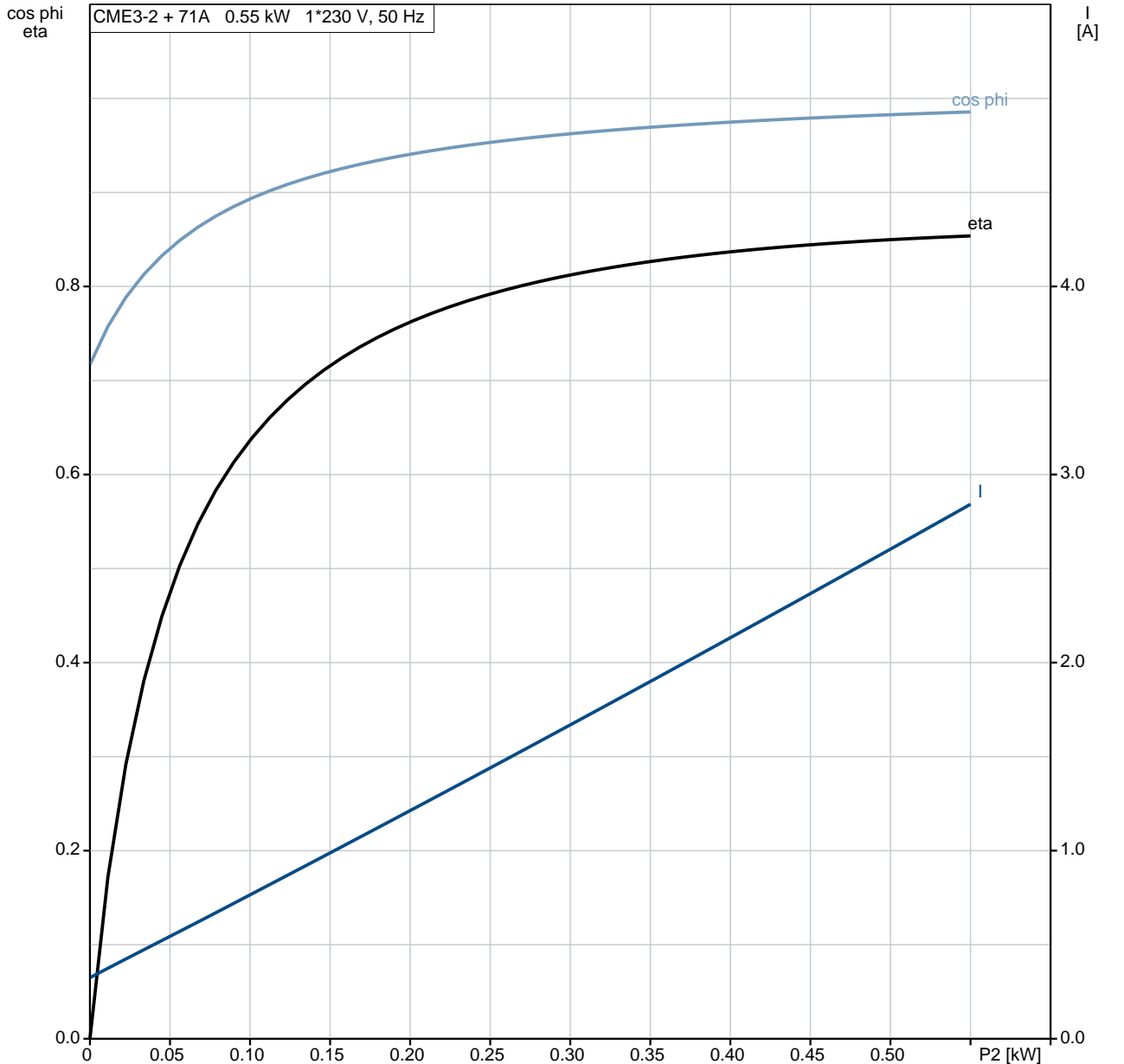

On request CME3-2 A-R-G-E-AQQE 50 Hz

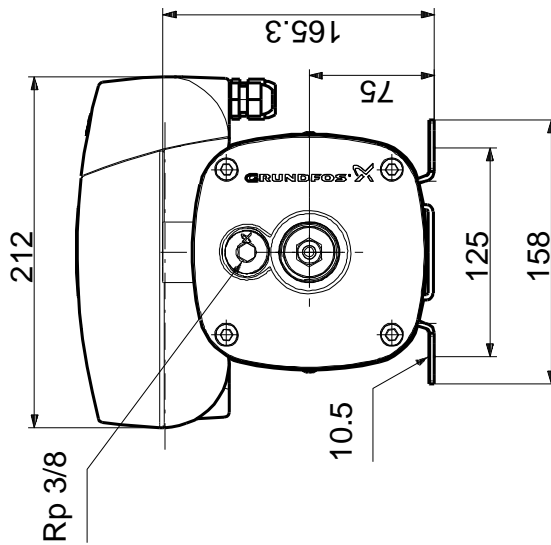
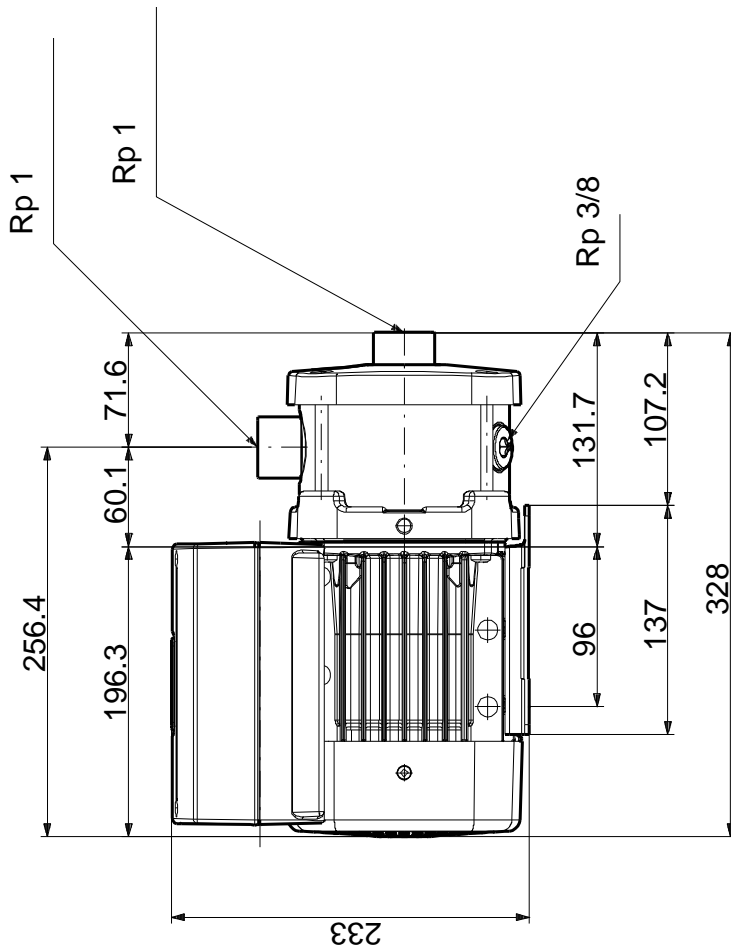

Note! All units are in [mm] unless others are stated.
 Disclaimer: This simplified dimensional drawing does not show all details.

Exploded view



Sectional drawing (TM058200 for TPE2,TPE3)

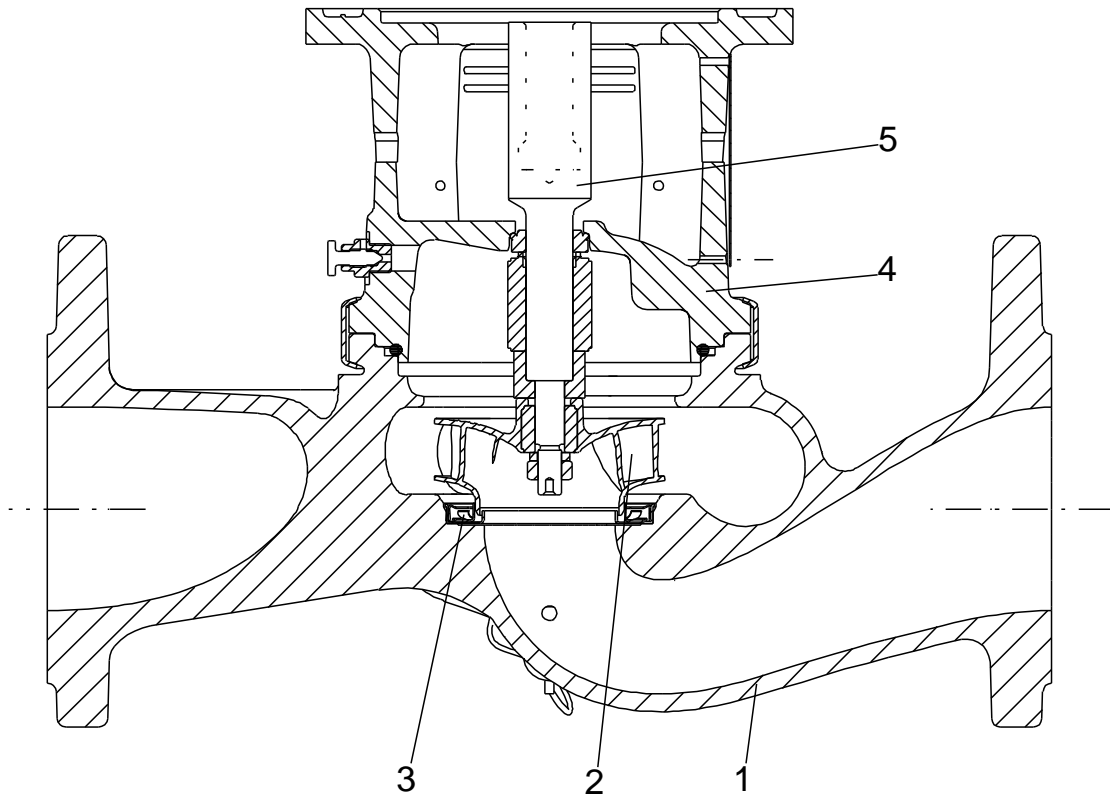

TM058200

Exploded view (TM057026 for MGE model H/I)



Parts list CME3-2, Product No. On request
Valid from 2.1.2013 (1301)

Pos	Description	Annotation	Données de classification	Référence	Quantité	Unité
+	MGE71A				1	pcs
	Cross recess countersunk screw				4	pcs
-	4.d Chamber cpl.				1	pcs
	Chamber				1	
	Retainer for seal ring				1	
	Guide vane				6	
	Plate				1	
	Vane				1	
45	Neck ring				1	
65	Neck ring retainer				1	
-	4e Chamber cpl.				1	pcs
	4a Intermediate chamber				1	
	45 Neck ring				1	
	65 Neck ring retainer				1	
	5a Chamber, empty				1	pcs
	6.a Flange				1	pcs
	16 Collar sleeve cpl.				1	pcs
-	25 Drain plug cpl.				2	pcs
	11 O-ring		Diameter: 18,5 Material type: EPDM Thickness: 2		1	
	25 Plug				1	
	26 Hex socket head cap screw		Length (mm): 80 Thread: M8		4	pcs
	31 O-ring		Diameter: 114 Material type: EPDM Thickness: 3,9		1	pcs
-	32 Cover				1	pcs
	Cover plate				1	
	Plate				1	
	36 Lock nut		Thread: M8		1	pcs
	49 Impeller cpl.				2	pcs
	51 Pump shaft		Diameter: D12		1	pcs
	64 Spacing pipe				1	pcs
	64.c Clamp				1	pcs
	66 Wedge lock washer				1	pcs
	76 Nameplate				2	pcs
-	105 Shaft seal				1	pcs
	102 O-ring		Diameter: 17,86 Material type: EPDM Thickness: 2,62		1	
	103 Seal ring, stationary				1	
	104 Seal ring, rotating				1	
	107 O-ring				1	
	108 Compression spring				1	
	111 Retainer				1	
	112 Driver for shaft seal				1	
	111.a Stop ring				1	pcs
	151 Fan cover				1	pcs
	152 Pan head thread forming screw				4	pcs
	156 Fan				1	pcs

Disclaimer: The information about the Grundfos pump in this document may be outdated.

Data may be subject to alterations without further notice.

Please contact us to verify the data above is still accurate/up-to-date.

All information is copyright Grundfos.



info@lenntech.com

<https://www.lenntech.com>

tel. +31 152 610 900

fax. +31 152 616 289