

## TP 25-80/2-A-O-A-BUBE 1X230 50HZ Grundfos pump 98346597



Thank you for your interest in our products. Please contact us for more information, or visit our website

<https://www.lenntech.com/grundfos/TP000/98346597/TP-25-80-2-A-O-A-BUBE.html>

[info@lenntech.com](mailto:info@lenntech.com)

tel. +31 152 610 900

fax. +31 152 616 289

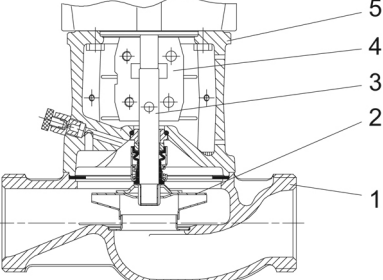
Position	Qty.	Description
	1	<p data-bbox="320 163 603 194"><b>TP 25-80/2 A-O-A-BUBE</b></p>  <p data-bbox="320 488 600 519">Product No.: On request</p> <p data-bbox="320 546 1445 622">Single-stage, close-coupled, volute pump with in-line suction and discharge ports of identical diameter. The pump is of the top-pull-out design, i.e. the power head (motor, pump head and impeller) can be removed for maintenance or service while the pump housing remains in the pipework.</p> <p data-bbox="320 631 1422 685">The pump is fitted with an unbalanced rubber bellows seal. The shaft seal is according to EN 12756. Pipework connection is via PN 10 union connections (ISO 228-1).</p> <p data-bbox="320 689 951 721">The pump is fitted with a fan-cooled asynchronous motor.</p> <p data-bbox="320 748 639 779"><b>Further product details</b></p> <p data-bbox="320 784 400 815"><b>Pump</b></p> <p data-bbox="320 819 1257 851">Pump housing and pump head are electrocoated to improve the corrosion resistance.</p> <p data-bbox="320 855 584 887">Electrocoating includes:</p> <ol data-bbox="320 891 810 999" style="list-style-type: none"> <li>1) Alkaline-based cleaning.</li> <li>2) Pretreatment with zinc phosphate coating.</li> <li>3) Cathodic electrocoating (epoxy).</li> <li>4) Curing of paint film at 200-250 °C.</li> </ol>  <ol data-bbox="320 1330 507 1473" style="list-style-type: none"> <li>1: Pump housing</li> <li>2: Impeller</li> <li>3: Shaft</li> <li>4: Coupling</li> <li>5: Pump head</li> </ol> <p data-bbox="320 1505 1461 1581">The pump housing is provided with a replaceable stainless steel/PTFE neck ring to reduce the amount of liquid running from the discharge side of the impeller to the suction side. The impeller is secured with a split cone pressed onto the shaft.</p> <p data-bbox="320 1621 1445 1697">The pump is fitted with an unbalanced rubber bellows seal with torque transmission across the spring and around the bellows. Due to the bellows, the seal does not wear the shaft, and the axial movement is not prevented by deposits on the shaft.</p> <p data-bbox="320 1711 464 1742">Primary seal:</p> <ul data-bbox="357 1742 1054 1796" style="list-style-type: none"> <li>• Rotating seal ring material: tungsten carbide (WC)</li> <li>• Stationary seat material: carbon graphite, resin-impregnated</li> </ul> <p data-bbox="320 1800 1430 1899">This is a widely used material pairing. If the pumped liquid contains particles, wear on the seal faces must be expected. Due to the favourable lubricating properties of carbon graphite, the seal is suitable for use even under poor lubricating conditions, such as hot water. However, under such conditions, wear on the carbon graphite face reduces seal life.</p> <p data-bbox="320 1912 1219 1966">Secondary seal material: EPDM (ethylene-propylene rubber) EPDM has excellent resistance to hot water. EPDM is not suitable for mineral oils.</p> <p data-bbox="320 2002 1445 2056">A circulation of liquid through the duct of the air vent screw ensures lubrication and cooling of the shaft seal.</p>

The motor stool forms connection between the pump housing and the motor, and is equipped with a manual air vent screw for venting of the pump housing and the shaft seal chamber. The sealing between motor stool and pump housing is an O-ring or a flat gasket.

The central part of the motor stool is provided with guards for protection against the shaft and coupling. Motor and pump shaft are connected via a shell coupling.

### Motor

The motor is a totally enclosed, fan-cooled motor with principal dimensions to IEC and DIN standards. Electrical tolerances comply with IEC 60034.

The motor is flange-mounted with tapped-hole flange (FT).

Motor-mounting designation in accordance with IEC 60034-7: IM B 14, IM V 18 (Code I) / IM 3601, IM 3611 (Code II).

The motor has built-in thermal protection (PTO current and temperature sensors) in accordance with IEC 60034-11 and requires no further motor protection. The protection reacts to both slow- and quick-rising temperatures, e.g. constant overload and stalled conditions.

As the thermal protection incorporates automatic reset, the motor must be connected in a way which ensures that the automatic reset cannot cause accidents.

### Technical data

#### Liquid:

Pumped liquid: Water  
Liquid temperature range: 0 .. 110 °C  
Liquid temperature during operation: 20 °C  
Density: 998.2 kg/m<sup>3</sup>

#### Technical:

Rated flow: 6.32 m<sup>3</sup>/h  
Rated head: 4.04 m  
Actual impeller diameter: 80 mm  
Primary shaft seal: BUBE  
Curve tolerance: ISO9906:2012 3B

#### Materials:

Pump housing: Cast iron  
EN-JL1020  
ASTM A48-25B  
Impeller: Composite PES/PP 30% GF

#### Installation:

Range of ambient temperature: -30 .. 40 °C  
Maximum operating pressure: 10 bar  
Flange standard: UNION  
Pipe connection: G 1 1/2  
Pressure rating: PN 10  
(@): 180 mm  
Flange size for motor: FT75

#### Electrical data:

Motor type: 71A  
Rated power - P2: 0.18 kW  
Power (P2) required by pump: 0.18 kW  
Mains frequency: 50 Hz  
Rated voltage: 1 x 220-240 V  
Rated current: 1.52-1.65 A  
Starting current: 520-525 %  
Cos phi - power factor: 0.85  
Rated speed: 2875-2895 rpm  
Motor efficiency at full load: 62.8-59 %  
Number of poles: 2  
Enclosure class (IEC 34-5): 55 Dust/Jetting  
Insulation class (IEC 85): F

Position	Qty.	Description
		<p><b>Others:</b>  Minimum efficiency index, MEI : 0.55  ErP status: EuP Standalone/Prod.  Net weight: 7.4 kg  Gross weight: 8.4 kg  Shipping volume: 0.02 m<sup>3</sup></p>

# On request TP 25-80/2 A-O-A-BUBE 50 Hz

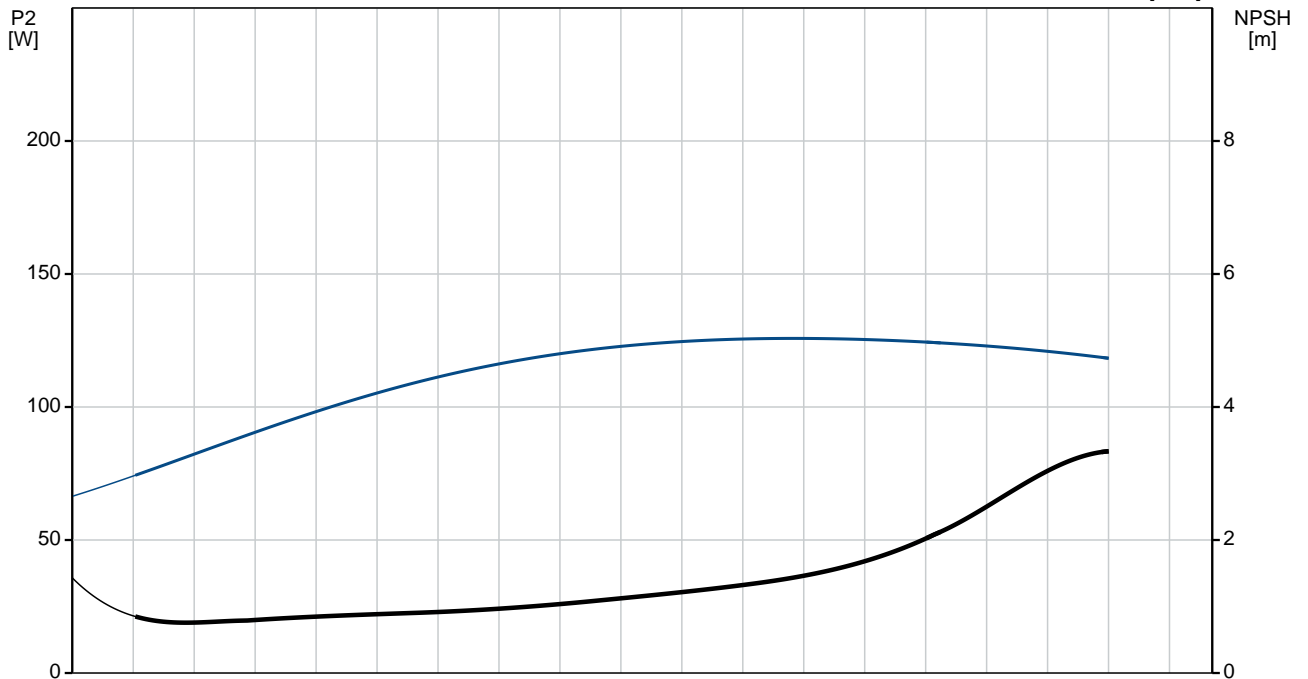
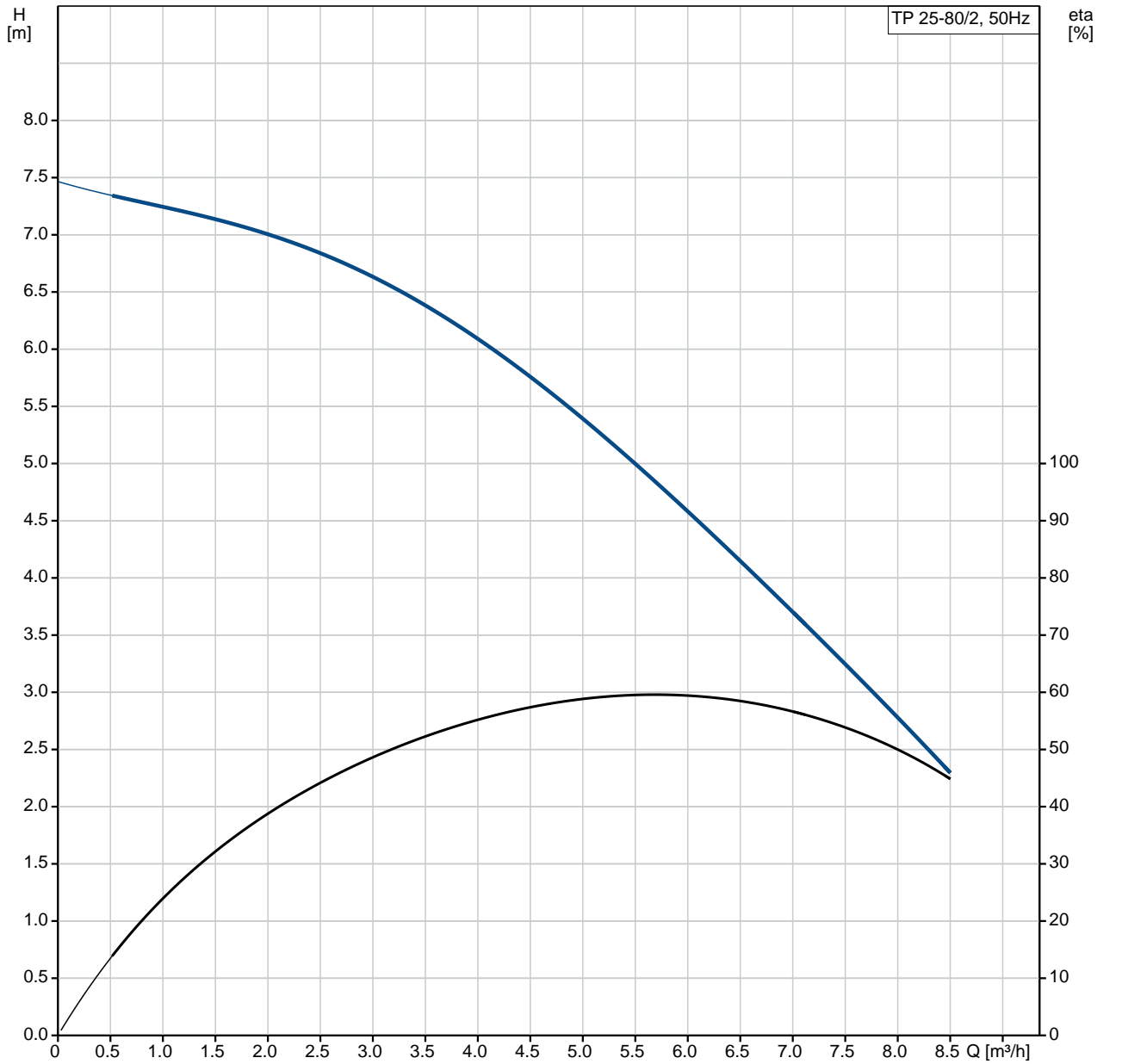

Description	Value
<b>General information:</b>	
Product name:	TP 25-80/2 A-O-A-BUBE
Product No:	On request
EAN number:	On request
<b>Technical:</b>	
Rated flow:	6.32 m <sup>3</sup> /h
Rated head:	4.04 m
Head max:	80 dm
Actual impeller diameter:	80 mm
Primary shaft seal:	BUBE
Curve tolerance:	ISO9906:2012 3B
Pump version:	A
Model:	B
<b>Materials:</b>	
Pump housing:	Cast iron EN-JL1020 ASTM A48-25B
Impeller:	Composite PES/PP 30% GF
Material code:	A
<b>Installation:</b>	
Range of ambient temperature:	-30 .. 40 °C
Maximum operating pressure:	10 bar
Flange standard:	UNION
Pipe connection:	G 1 1/2
Pressure rating:	PN 10
(@)	180 mm
Flange size for motor:	FT75
Connect code:	O
<b>Liquid:</b>	
Pumped liquid:	Water
Liquid temperature range:	0 .. 110 °C
Liquid temperature during operation:	20 °C
Density:	998.2 kg/m <sup>3</sup>
<b>Electrical data:</b>	
Motor type:	71A
Rated power - P2:	0.18 kW
Power (P2) required by pump:	0.18 kW
Mains frequency:	50 Hz
Rated voltage:	1 x 220-240 V
Rated current:	1.52-1.65 A
Starting current:	520-525 %
Cos phi - power factor:	0.85
Rated speed:	2875-2895 rpm
Motor efficiency at full load:	62.8-59 %
Number of poles:	2
Enclosure class (IEC 34-5):	55 Dust/Jetting
Insulation class (IEC 85):	F
Motor protec:	PTO
Motor No:	98714252
<b>Others:</b>	
Minimum efficiency index, MEI :	0.55
ErP status:	EuP Standalone/Prod.
Net weight:	7.4 kg
Gross weight:	8.4 kg
Shipping volume:	0.02 m <sup>3</sup>

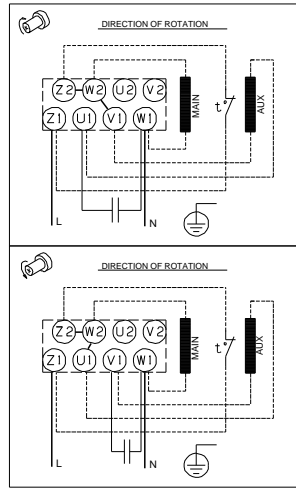
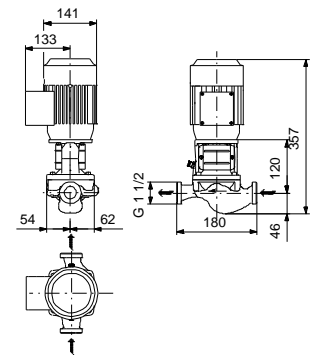
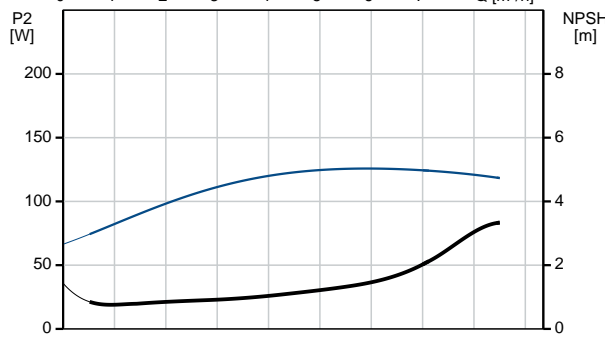
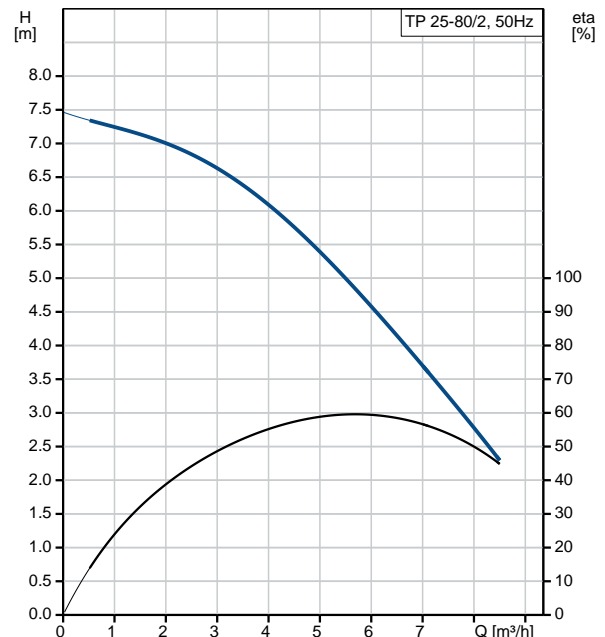

# On request TP 25-80/2 A-O-A-BUBE 50 Hz

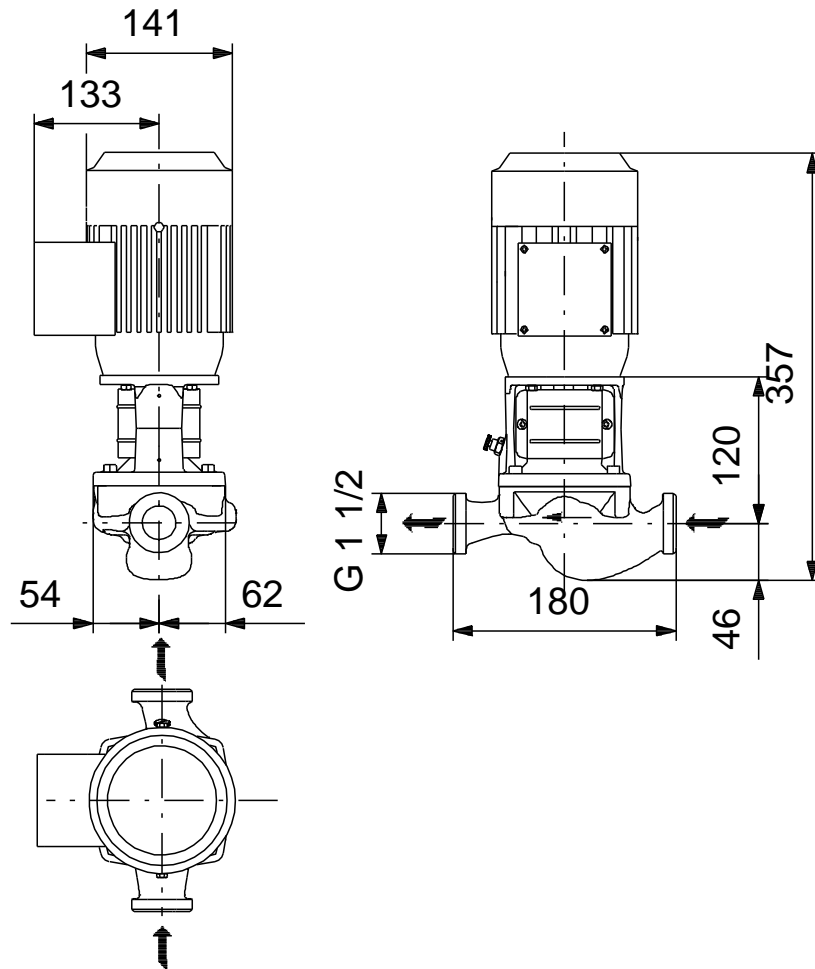

Note! All units are in [mm] unless others are stated.  
Disclaimer: This simplified dimensional drawing does not show all details.

**Exploded view**

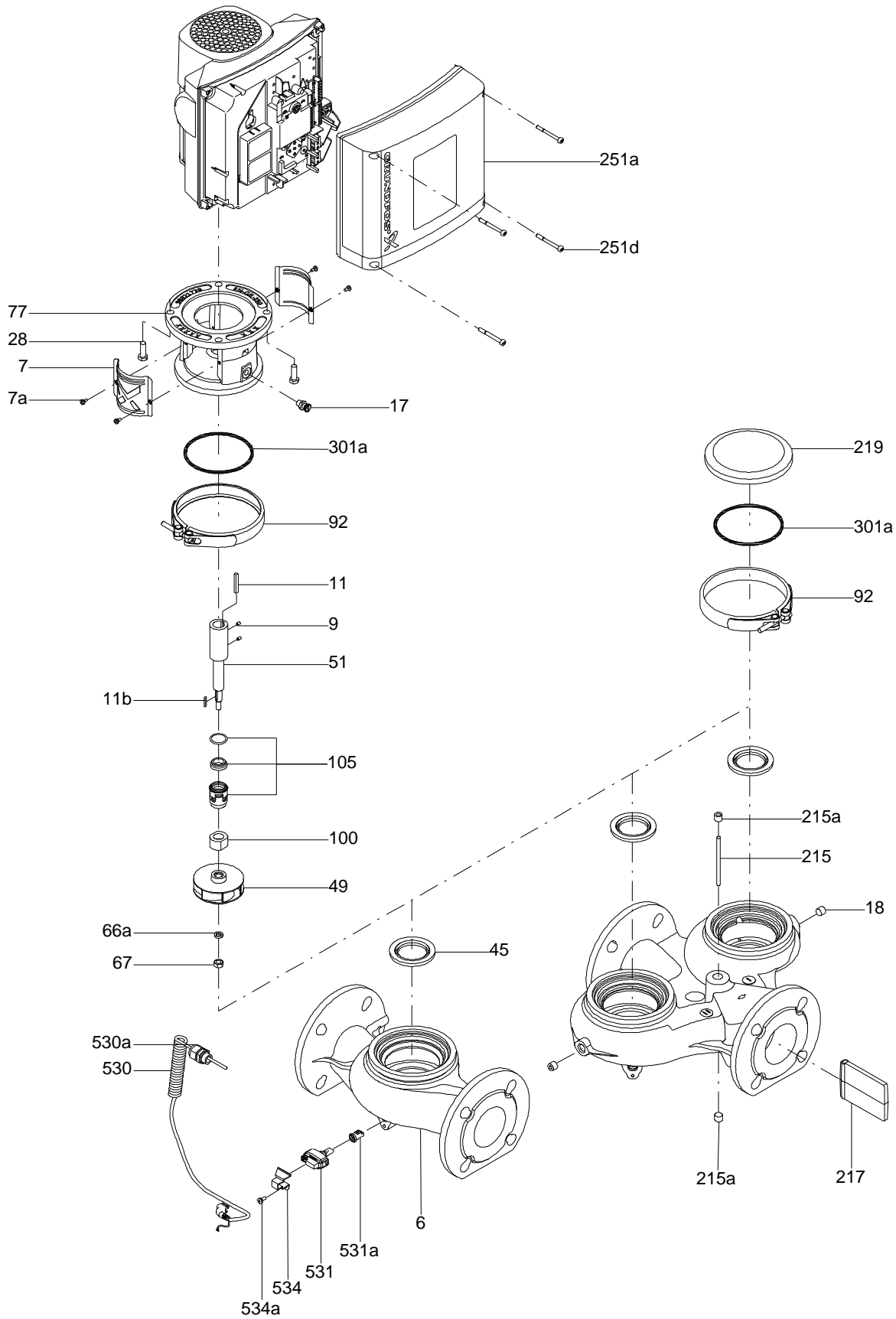



Sectional drawing (TM058200 for TPE2,TPE3)

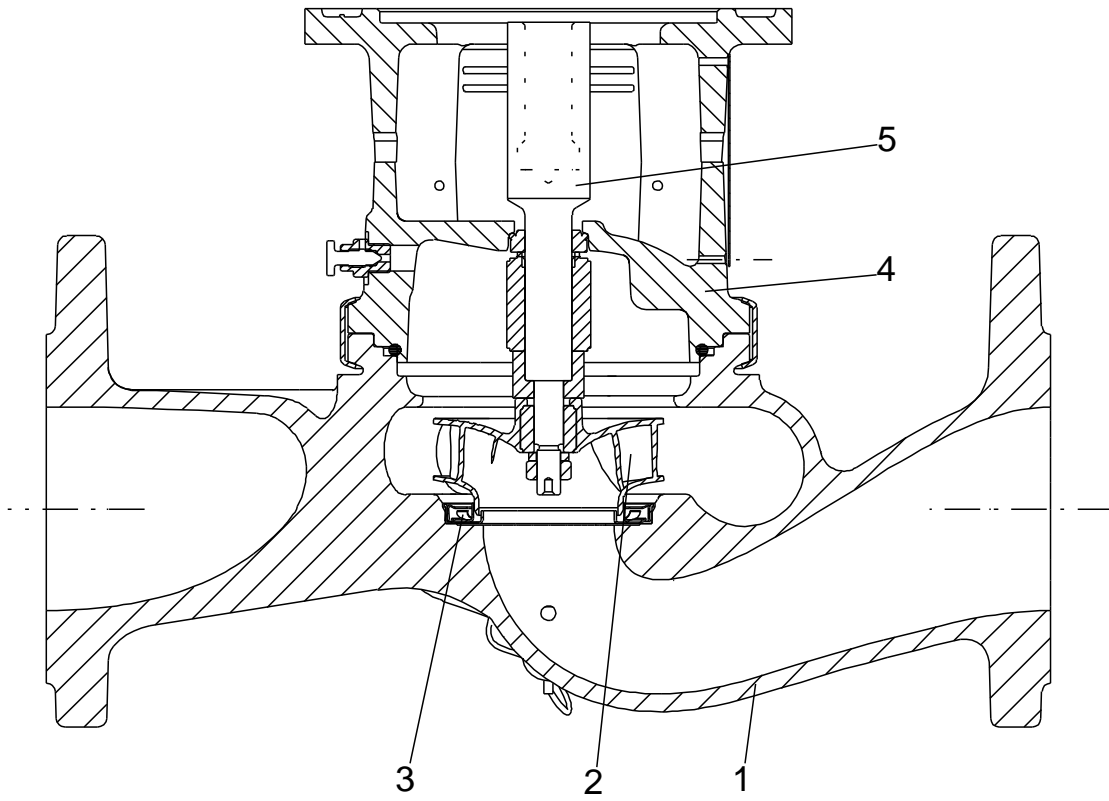

TM058200

Exploded view ( TM057026 for MGE model H/I )

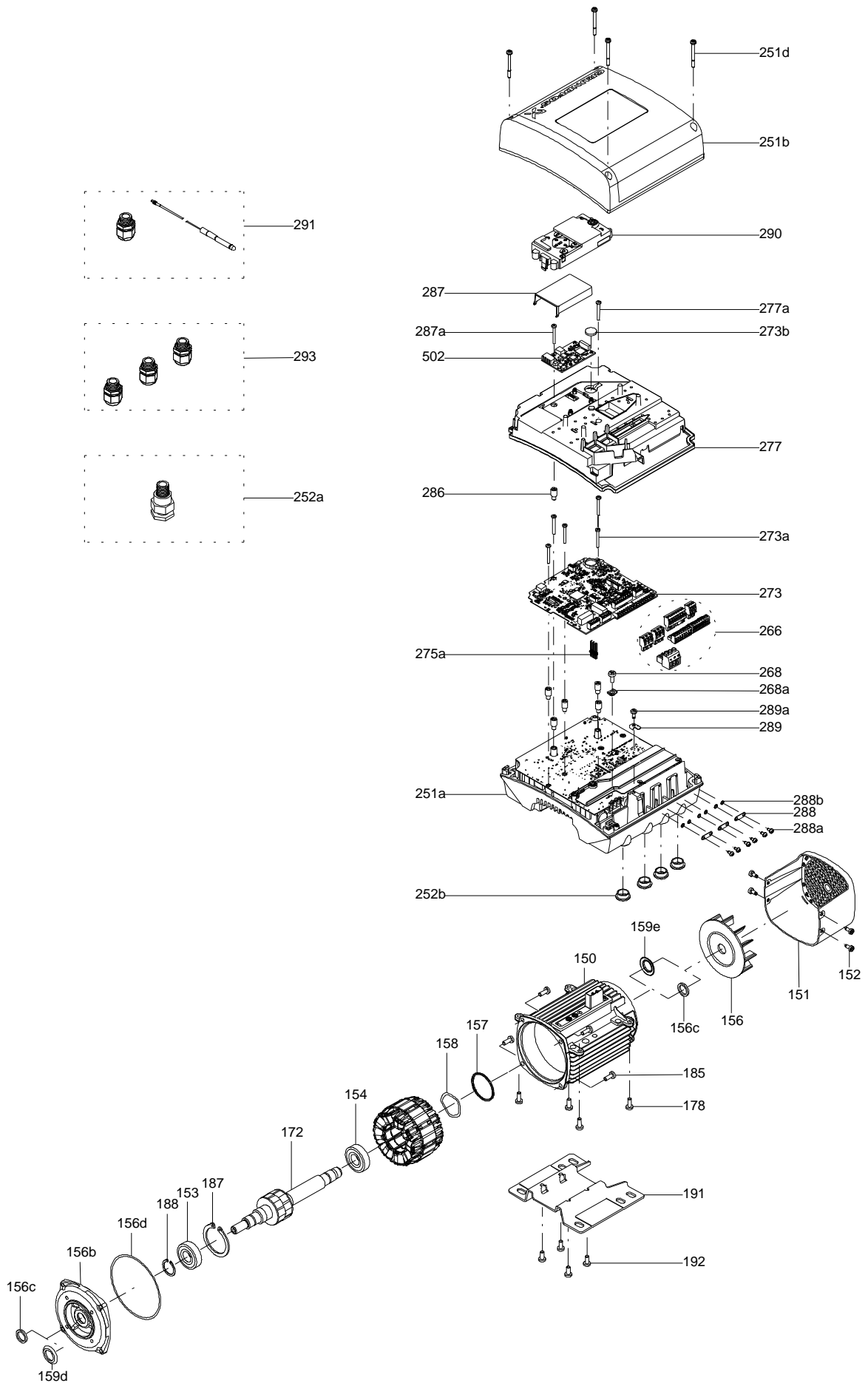

**Parts list TP 25-80/2, Product No. On request**  
**Valid from 20.6.2010 (1024)**

Pos	Description	Annotation	Données de classification	Référence	Quantité	Unité
	Motor				1	pcs
-	Coupling cpl.				1	pcs
9	Hex socket head cap screw		Designation: DIN 912 Length (mm): 20 Thread: M6		4	
10	Shaft pin		Diameter: 5 Length (mm): 21,5		1	
10a	Coupling half				2	
-	Motor stool cpl.				1	pcs
2	Motor stool				1	
26	Hex socket head cap screw		Designation: DIN 912 Length (mm): 20 Thread: M6		4	
28	Hex head screw		Length (mm): 16 MM Thread: M5		4	
-	Pump housing cpl.				1	pcs
- 6	Pump housing cpl.				1	
-	Pump housing				1	
6	Pump housing					
45	Seal ring					
-	Coupling guard cpl.				1	pcs
7	Coupling guard				2	
7a	Pan head screw				4	
66	Lock washer				4	
-	Shaft w/impeller cpl.				1	pcs
-	Shaft w/impeller cpl.				1	
49	Impeller cpl.				1	
49b	Split cone				1	
51	Pump shaft				1	
66a	Washer		Designation: DIN 125 A2 Internal diameter: 13 Outer diameter: 24 Thickness: 2,5		1	
17	Air vent screw				1	pcs
72a	Gasket		Internal diameter: 97 MM Outer diameter: 77.5 Thickness: 2 MM		1	pcs
105	Shaft seal		Material type: BUBE		1	pcs

*Disclaimer: The information about the Grundfos pump in this document may be outdated.*

*Data may be subject to alterations without further notice.*

*Please contact us to verify the data above is still accurate/up-to-date.*

All information is copyright Grundfos.



[info@lenntech.com](mailto:info@lenntech.com)

<https://www.lenntech.com>

tel. +31 152 610 900

fax. +31 152 616 289