

MAGNA1 32-60 F N 220 1x230V PN6/10 Grundfos pump 98333846



Thank you for your interest in our products. Please contact us for more information, or visit our website

<https://www.lenntech.com/grundfos/MAGNA1N/98333846/MAGNA1-32-60-F-N.html>

info@lenntech.com

tel. +31 152 610 900

fax. +31 152 616 289

Position	Qty.	Description
	1	<p>MAGNA1 32-60 F N</p>  <p>Product No.: On request</p> <p>MAGNA1 circulator pump with easy selection of pump setting The pump is of the canned-rotor type, i.e. pump and motor form an integral unit without shaft seal and with only two gaskets for sealing. The bearings are lubricated by the pumped liquid. In order to avoid problems in connection with disposal, great importance has been attached to using as few different materials as possible. A pump with no maintenance requirements and extremely low life cycle cost.</p> <p>Heating systems</p> <ul style="list-style-type: none"> • Main pump • mixing loops • heating surfaces • air-conditioning surfaces. <p>The MAGNA1 circulator pumps are designed for circulating liquids in heating systems with variable flows where it is desirable to optimise the setting of the pump duty point, thus reducing energy costs. The pumps are also suitable for domestic hot-water systems.</p> <p>To ensure correct operation, it is important that the sizing range of the system falls within the duty range of the pump.</p> <p>Benefits</p> <ul style="list-style-type: none"> • Safe selection. • Simple installation. • Low energy consumption. All MAGNA1 pumps comply with the EuP requirements. • Nine light fields for indication of pump setting. Three proportional-pressure curves, three constant-pressure curves and three fixed-speed curves are available. • Low noise level. • No maintenance and long life. <p>Liquid:</p> <p>Pumped liquid: Water Liquid temperature range: -10 .. 110 °C Liquid temperature during operation: 60 °C Density: 983.2 kg/m³</p> <p>Technical:</p> <p>TF class: 110 Approvals on nameplate: CE,VDE,EAC,CN ROHS</p> <p>Materials:</p> <p>Pump housing: Stainless steel EN 1.4308 ASTM 351 CF8</p> <p>Impeller: PES 30%GF</p> <p>Installation:</p> <p>Range of ambient temperature: 0 .. 40 °C Maximum operating pressure: 10 bar Flange standard: DIN</p>

Position	Qty.	Description
		Pipe connection: DN 32 Pressure rating: PN6/10 (@): 220 mm Electrical data: Power input - P1: 9 .. 111 W Mains frequency: 50 Hz Rated voltage: 1 x 230 V Maximum current consumption: 0.09 .. 0.9 A Enclosure class (IEC 34-5): X4D Insulation class (IEC 85): F Others: Energy (EEI): 0.22 Net weight: 7.36 kg Gross weight: 7.84 kg Shipping volume: 0.016 m ³ Danish VVS No.: 380781061 Norwegian NRF no.: 9042102

On request MAGNA1 32-60 F N 50 Hz

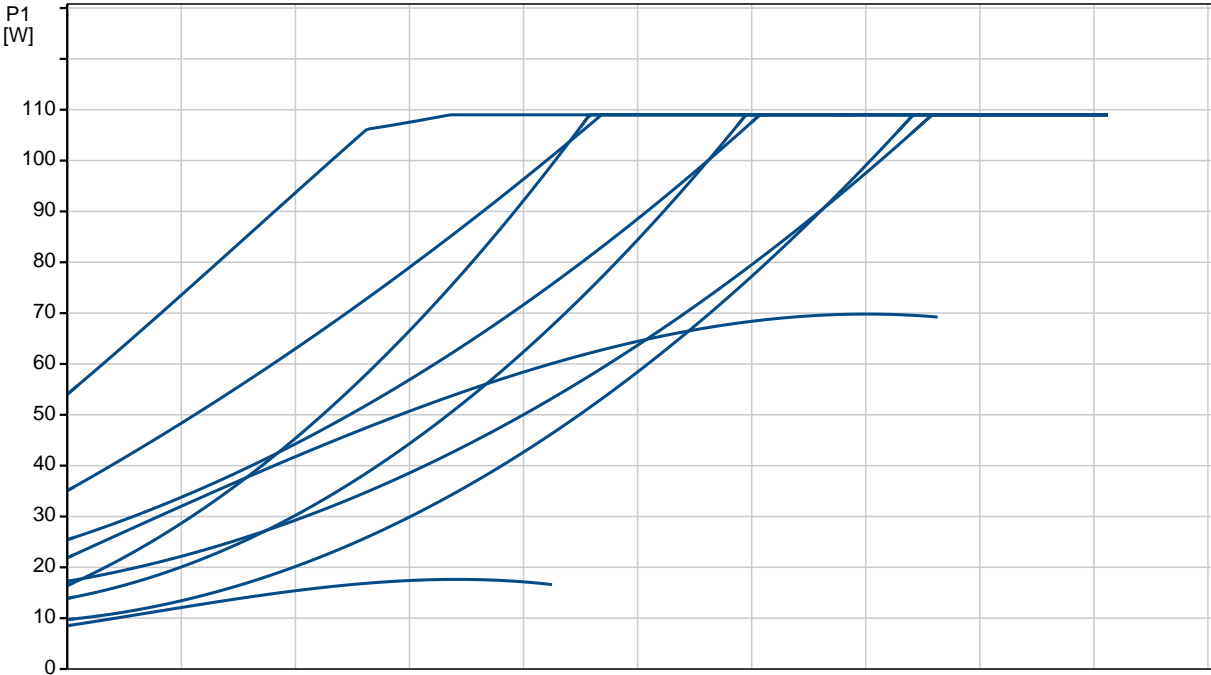
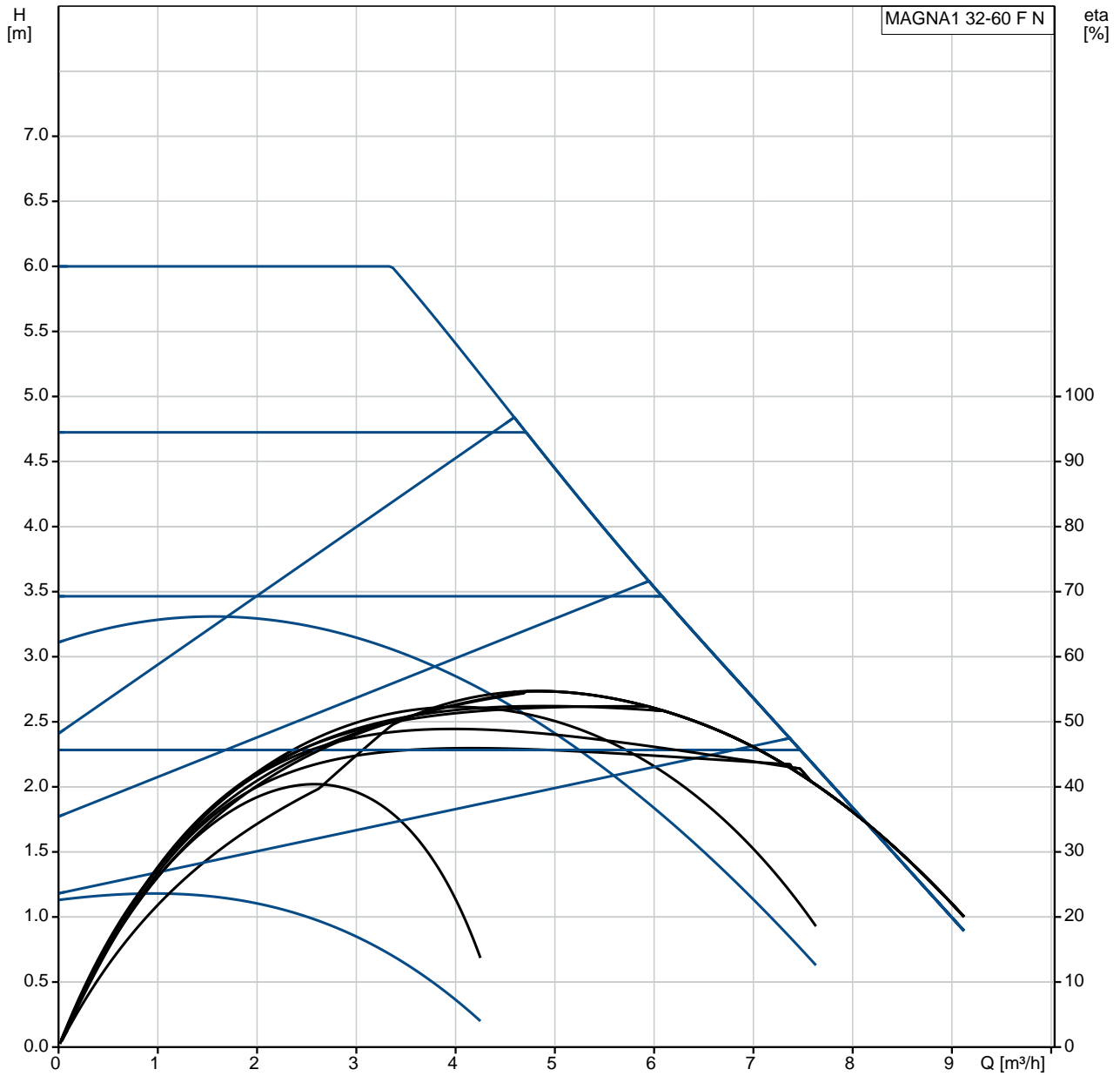

Description	Value
General information:	
Product name:	MAGNA1 32-60 F N
Product No:	On request
EAN number:	On request
Technical:	
Head max:	60 dm
TF class:	110
Approvals on nameplate:	CE,VDE,EAC,CN ROHS
Model:	A
Materials:	
Pump housing:	Stainless steel EN 1.4308 ASTM 351 CF8
Impeller:	PES 30%GF
Installation:	
Range of ambient temperature:	0 .. 40 °C
Maximum operating pressure:	10 bar
Flange standard:	DIN
Pipe connection:	DN 32
Pressure rating:	PN6/10 (@) 220 mm
Liquid:	
Pumped liquid:	Water
Liquid temperature range:	-10 .. 110 °C
Liquid temperature during operation:	60 °C
Density:	983.2 kg/m ³
Electrical data:	
Power input - P1:	9 .. 111 W
Mains frequency:	50 Hz
Rated voltage:	1 x 230 V
Maximum current consumption:	0.09 .. 0.9 A
Enclosure class (IEC 34-5):	X4D
Insulation class (IEC 85):	F
Others:	
Energy (EEI):	0.22
Net weight:	7.36 kg
Gross weight:	7.84 kg
Shipping volume:	0.016 m ³
Danish VVS No.:	380781061
Norwegian NRF no.:	9042102

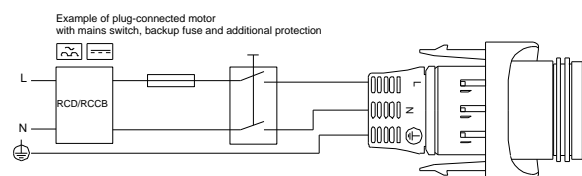
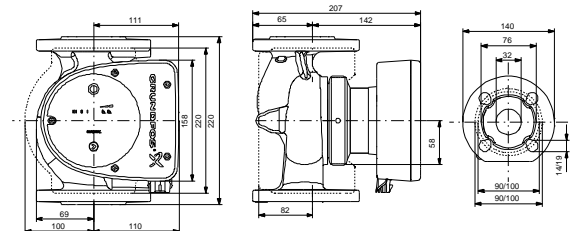
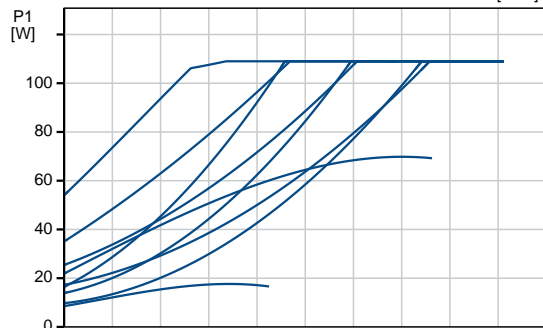
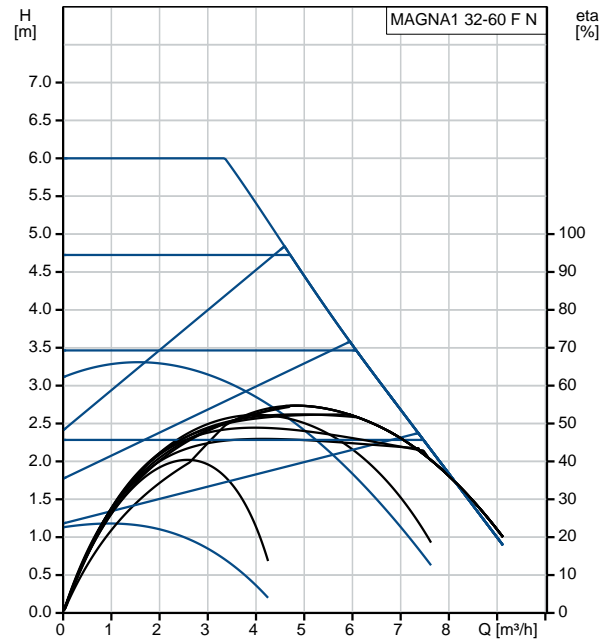

On request MAGNA1 32-60 F N 50 Hz

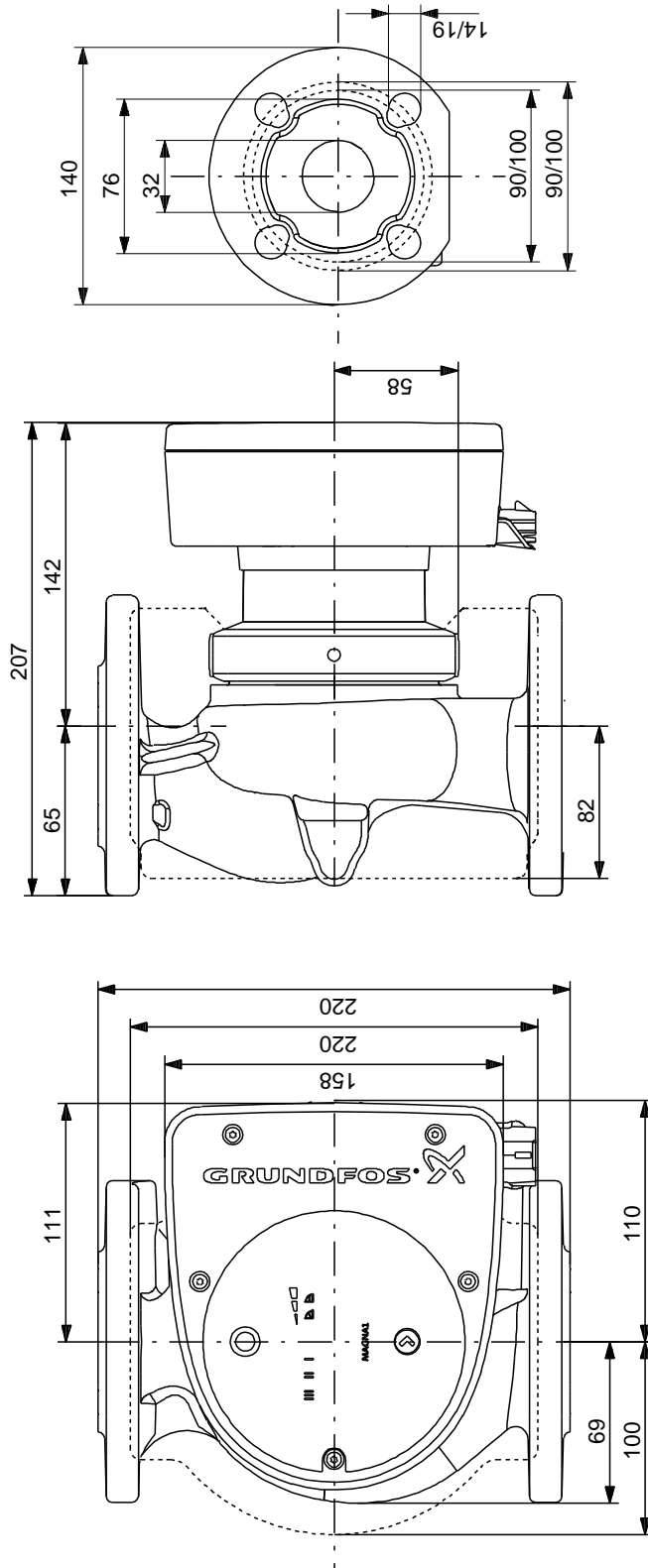

Note! All units are in [mm] unless others are stated.
Disclaimer: This simplified dimensional drawing does not show all details.

Exploded view

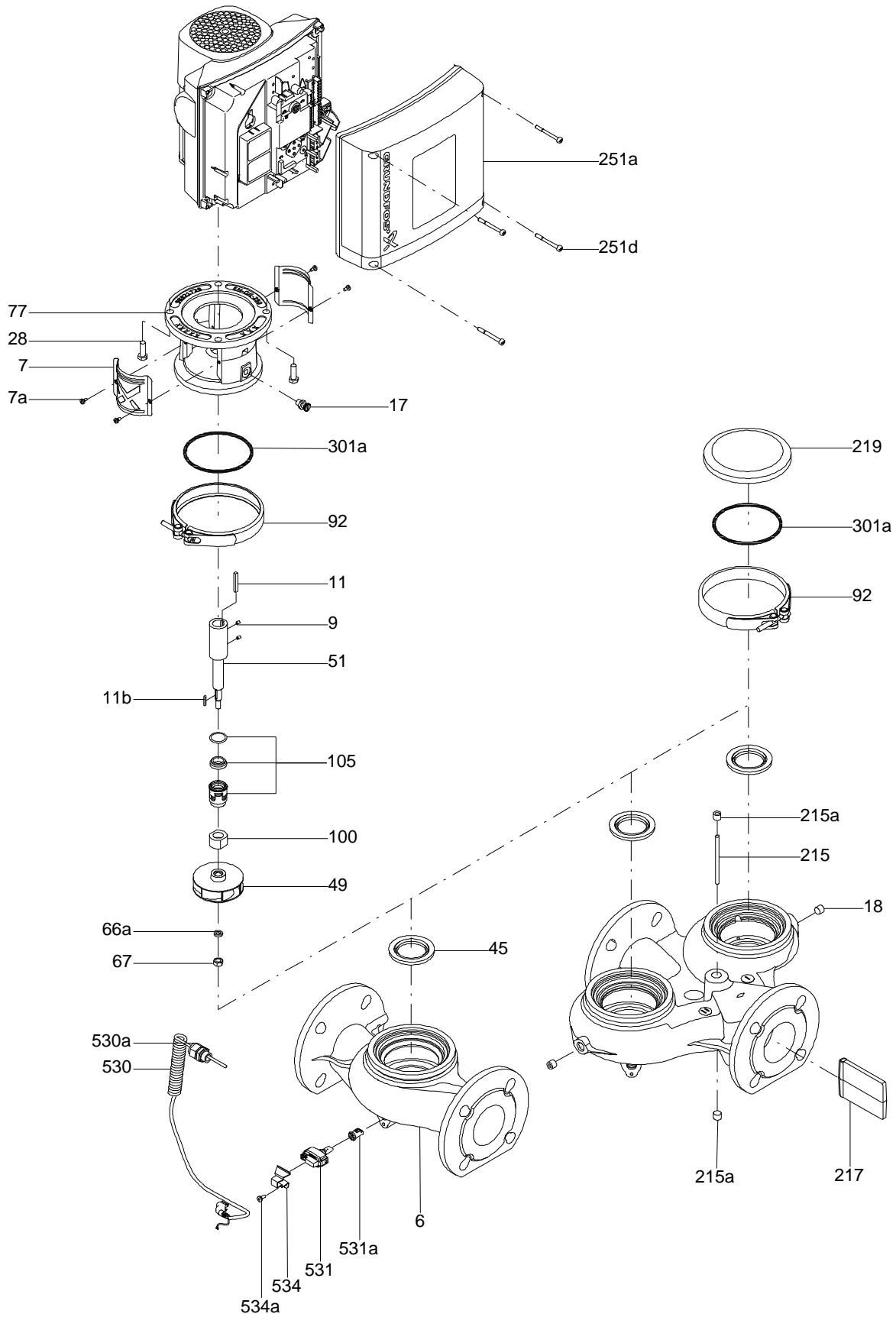

Sectional drawing (TM058200 for TPE2,TPE3)

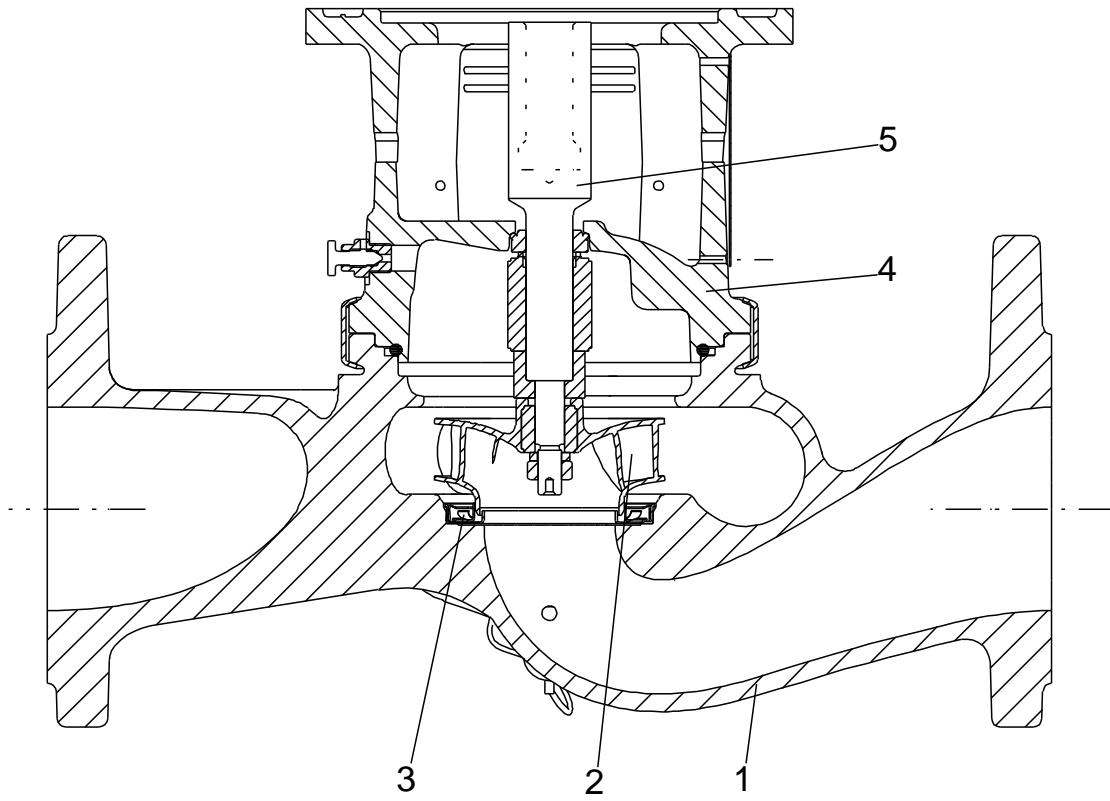

TM058200

Exploded view (TM057026 for MGE model H/I)

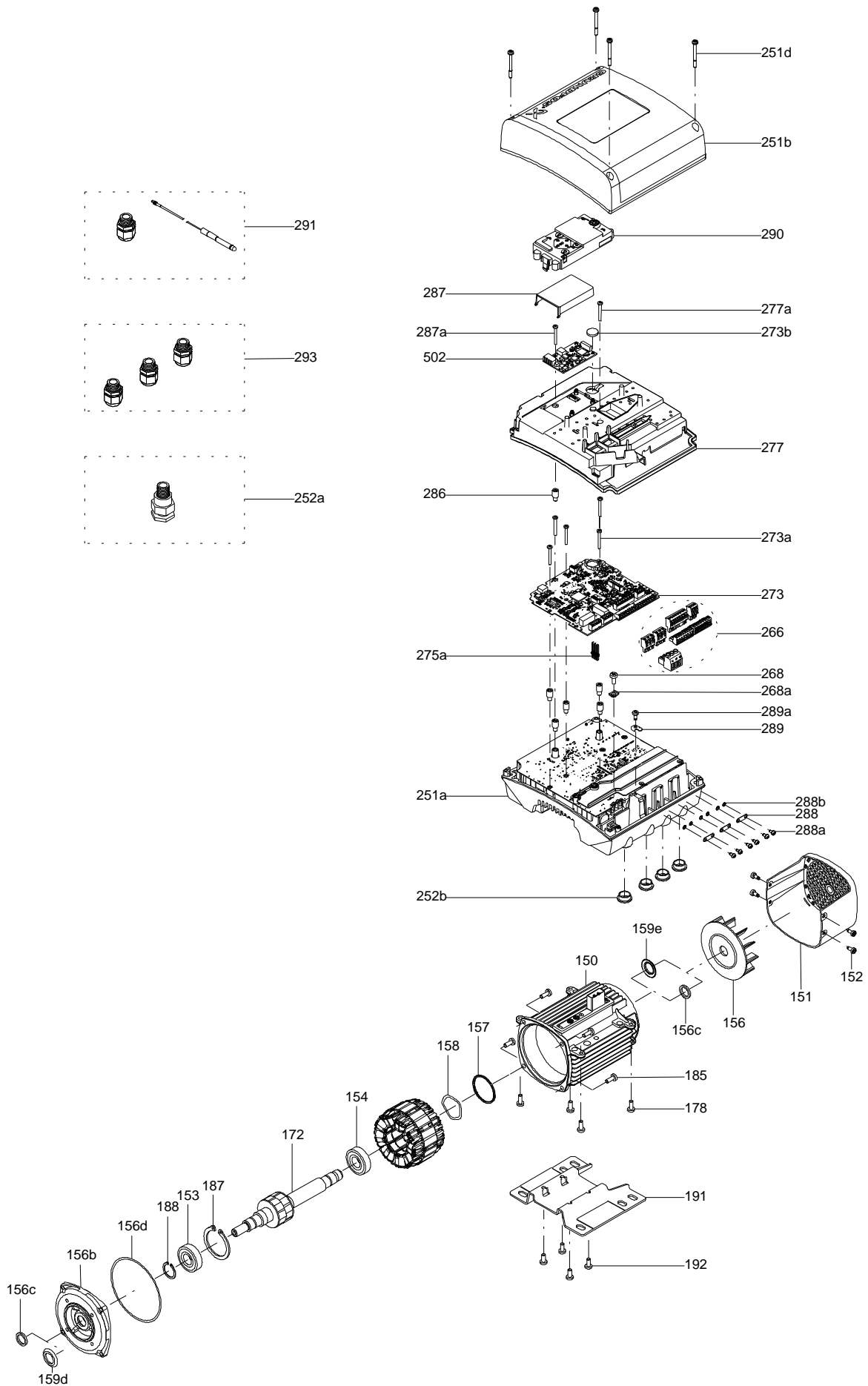

Parts list MAGNA1 32-60 F N, Product No. On request
Valid from 18.10.2012 (1242)

Pos	Description	Annotation	Données de classification	Référence	Quantité	Unité
-	Pump housing cpl.				1	pcs
	Flange				2	
	Lock ring				2	
	Cylinder				2	
6	Pump housing				1	
45	Neck ring				1	
-	Control box				1	pcs
	Screw w/washer				3	
163	Bottom				1	
164	Cover				1	
164a	Screw DELTA PT				5	
	Foil				1	pcs
92	Clamp cpl.				1	pcs
163a	Pan head screw				2	pcs
302	Pump head				1	pcs
450	Insulation shell				1	pcs

Disclaimer: The information about the Grundfos pump in this document may be outdated.

Data may be subject to alterations without further notice.

Please contact us to verify the data above is still accurate/up-to-date.

All information is copyright Grundfos.



info@lenntech.com

<https://www.lenntech.com>

tel. +31 152 610 900

fax. +31 152 616 289