

TP 200-160/4-A-F-A-BQQE 400D 50HZ Grundfos pump 97927159



Thank you for your interest in our products. Please contact us for more information, or visit our website

<https://www.lenntech.com/grundfos/TP000/97927159/TP-200-160-4-A-F-A-BQQE.html>

info@lenntech.com

tel. +31 152 610 900

fax. +31 152 616 289

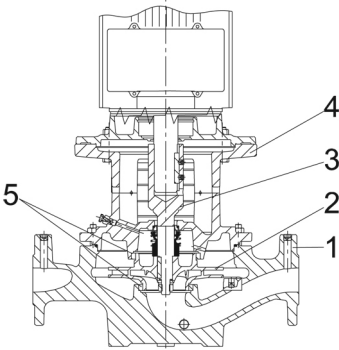
Position	Qty.	Description
	1	<p data-bbox="320 163 628 194">TP 200-160/4 A-F-A-BQQE</p>  <p data-bbox="320 483 600 515">Product No.: On request</p> <p data-bbox="320 544 1445 620">Single-stage, close-coupled, volute pump with in-line suction and discharge ports of identical diameter. The pump is of the top-pull-out design, i.e. the power head (motor, pump head and impeller) can be removed for maintenance or service while the pump housing remains in the pipework.</p> <p data-bbox="320 629 1422 680">The pump is fitted with an unbalanced rubber bellows seal. The shaft seal is according to EN 12756. Pipework connection is via PN 16 DIN flanges (EN 1092-2 and ISO 7005-2).</p> <p data-bbox="320 687 951 719">The pump is fitted with a fan-cooled asynchronous motor.</p> <p data-bbox="320 745 639 777">Further product details</p> <p data-bbox="320 781 1426 857">The product's minimum efficiency index (MEI) is greater or equal to 0.70. This is by the Commission Regulation (EU) considered as an indicative benchmark for best-performing water pump available on the market as from 1 January 2013.</p> <p data-bbox="320 896 403 927">Pump</p> <p data-bbox="320 931 1256 963">Pump housing and pump head are electrocoated to improve the corrosion resistance.</p> <p data-bbox="320 965 584 996">Electrocoating includes:</p> <ol data-bbox="320 999 810 1111" style="list-style-type: none"> 1) Alkaline-based cleaning. 2) Pretreatment with zinc phosphate coating. 3) Cathodic electrocoating (epoxy). 4) Curing of paint film at 200-250 °C.  <ol data-bbox="320 1516 608 1664" style="list-style-type: none"> 1: Pump housing 2: Impeller 3: Stub shaft 4: Pump head/motor stool 5: Wear rings <p data-bbox="320 1693 1461 1747">The pump housing is provided with a replaceable brass neck ring to reduce the amount of liquid running from the outlet side of the impeller to the inlet side. The impeller is secured to the shaft with a nut.</p> <p data-bbox="320 1809 1441 1886">The pump is fitted with an unbalanced rubber bellows seal with torque transmission across the spring and around the bellows. Due to the bellows, the seal does not wear the shaft, and the axial movement is not prevented by deposits on the shaft.</p> <p data-bbox="320 1895 467 1926">Primary seal:</p> <ul data-bbox="357 1928 919 1984" style="list-style-type: none"> • Rotating seal ring material: silicon carbide (SiC) • Stationary seat material: silicon carbide (SiC) <p data-bbox="320 1986 1426 2040">This material pairing is used where higher corrosion resistance is required. The high hardness of this material pairing offers good resistance against abrasive particles.</p> <p data-bbox="320 2042 986 2074">Secondary seal material: EPDM (ethylene-propylene rubber)</p> <p data-bbox="320 2076 1219 2107">EPDM has excellent resistance to hot water. EPDM is not suitable for mineral oils.</p>

Position	Qty.	Description
		<p>A circulation of liquid through the duct of the air vent screw ensures lubrication and cooling of the shaft seal.</p> <p>The flanges have tappings for mounting of pressure gauges.</p> <p>The motor stool forms connection between the pump housing and the motor, and is equipped with a manual air vent screw for venting of the pump housing and the shaft seal chamber. The sealing between motor stool and pump housing is an O-ring.</p> <p>The central part of the motor stool is provided with guards for protection against the shaft and coupling. The pump shaft is fastened directly on the motor shaft with key and set screws.</p> <p>Motor</p> <p>The motor is a totally enclosed, fan-cooled motor with principal dimensions to IEC and DIN standards. Electrical tolerances comply with IEC 60034.</p> <p>The motor is flange-mounted with free-hole flange (FF). Motor-mounting designation in accordance with IEC 60034-7: IM B 5, IM V 1 (Code I) / IM 3001, IM 3011 (Code II).</p> <p>The motor efficiency is classified as IE3 in accordance with IEC 60034-30-1. The motor has thermistors (PTC sensors) in the windings in accordance with DIN 44081/DIN 44082. The protection reacts to both slow- and quick-rising temperatures, e.g. constant overload and stalled conditions.</p> <p>Thermal switches must be connected to an external control circuit in a way which ensures that the automatic reset cannot cause accidents. The motors must be connected to a motor-protective circuit breaker according to local regulations.</p> <p>The motor can be connected to a variable speed drive for adjustment of pump performance to any duty point. Grundfos CUE offers a range of variable speed drives. Please find more information in Grundfos Product Center.</p> <p>Technical data</p> <p>Liquid: Pumped liquid: Water Liquid temperature range: -25 .. 120 °C Liquid temperature during operation: 20 °C Density: 998.2 kg/m³</p> <p>Technical: Rated flow: 399 m³/h Rated head: 10 m Actual impeller diameter: 226-220 mm Primary shaft seal: BQQE Curve tolerance: ISO9906:2012 3B</p> <p>Materials: Pump housing: Cast iron EN-JL1040 ASTM A48-40 B Impeller: Cast iron EN-JL1030 ASTM A48-30 B</p> <p>Installation: Range of ambient temperature: -30 .. 60 °C Maximum operating pressure: 16 bar Flange standard: DIN Pipe connection: DN 200 Pump inlet: DN 200 Pump outlet: DN 200 Pressure rating: PN 16 (@): 900 mm Flange size for motor: FF300</p> <p>Electrical data:</p>

Position	Qty.	Description
		<p> Motor type: 160LB IE Efficiency class: IE3 Rated power - P2: 15 kW Power (P2) required by pump: 15 kW Mains frequency: 50 Hz Rated voltage: 3 x 380-415D/660-690Y V Rated current: 29,0-28,0/16,8-16,4 A Starting current: 760-870 % Cos phi - power factor: 0.86-0.82 Rated speed: 1460-1470 rpm Efficiency: IE3 92,1% Motor efficiency at full load: 92.1 % Motor efficiency at 3/4 load: 92.3 % Motor efficiency at 1/2 load: 92.1 % Number of poles: 4 Enclosure class (IEC 34-5): 55 Dust/Jetting Insulation class (IEC 85): F </p> <p> Others: Minimum efficiency index, MEI : 0.70 ErP status: EuP Standalone/Prod. Net weight: 417 kg Gross weight: 513 kg Shipping volume: 2.29 m³ Danish VVS No.: 381719160 </p>

On request TP 200-160/4 A-F-A-BQQE 50 Hz

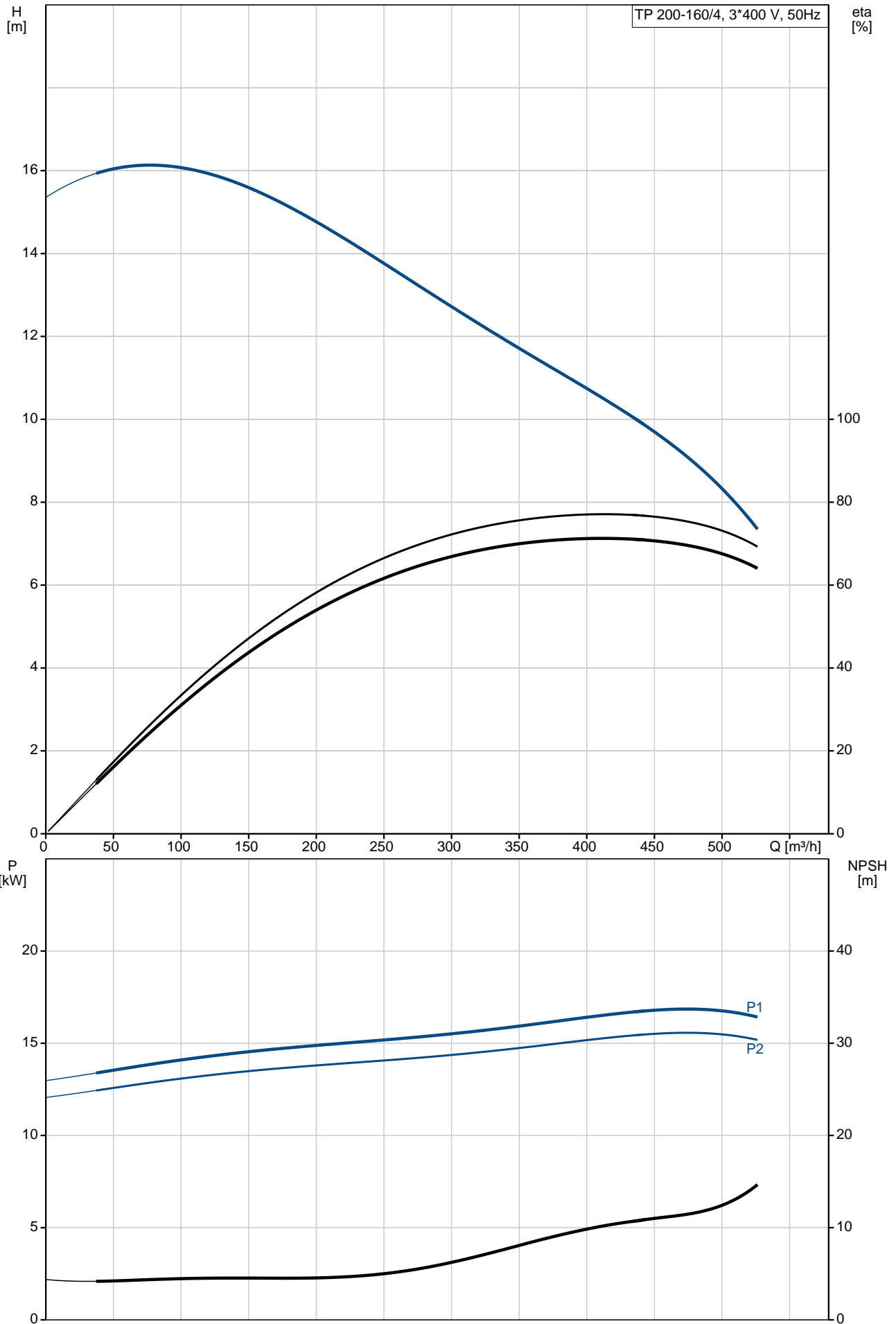

Description	Value
General information:	
Product name:	TP 200-160/4 A-F-A-BQQE
Product No:	On request
EAN number:	On request
Technical:	
Rated flow:	399 m ³ /h
Rated head:	10 m
Head max:	160 dm
Actual impeller diameter:	226-220 mm
Primary shaft seal:	BQQE
Curve tolerance:	ISO9906:2012 3B
Pump version:	A
Model:	A
Materials:	
Pump housing:	Cast iron EN-JL1040 ASTM A48-40 B
Impeller:	Cast iron EN-JL1030 ASTM A48-30 B
Material code:	A
Installation:	
Range of ambient temperature:	-30 .. 60 °C
Maximum operating pressure:	16 bar
Flange standard:	DIN
Pipe connection:	DN 200
Pump inlet:	DN 200
Pump outlet:	DN 200
Pressure rating:	PN 16
(@)	900 mm
Flange size for motor:	FF300
Connect code:	F
Liquid:	
Pumped liquid:	Water
Liquid temperature range:	-25 .. 120 °C
Liquid temperature during operation:	20 °C
Density:	998.2 kg/m ³
Electrical data:	
Motor type:	160LB
IE Efficiency class:	IE3
Rated power - P2:	15 kW
Power (P2) required by pump:	15 kW
Mains frequency:	50 Hz
Rated voltage:	3 x 380-415D/660-690Y V
Rated current:	29,0-28,0/16,8-16,4 A
Starting current:	760-870 %
Cos phi - power factor:	0.86-0.82
Rated speed:	1460-1470 rpm
Efficiency:	IE3 92,1%
Motor efficiency at full load:	92.1 %
Motor efficiency at 3/4 load:	92.3 %
Motor efficiency at 1/2 load:	92.1 %
Number of poles:	4
Enclosure class (IEC 34-5):	55 Dust/Jetting
Insulation class (IEC 85):	F
Motor protec:	PTC
Motor No:	87420032
Others:	
Minimum efficiency index, MEI :	0.70
ErP status:	EuP Standalone/Prod.
Net weight:	417 kg
Gross weight:	513 kg
Shipping volume:	2.29 m ³
Danish VVS No.:	381719160

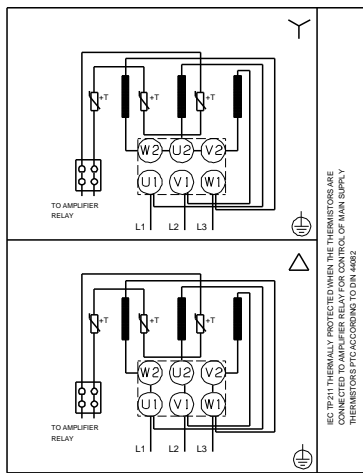
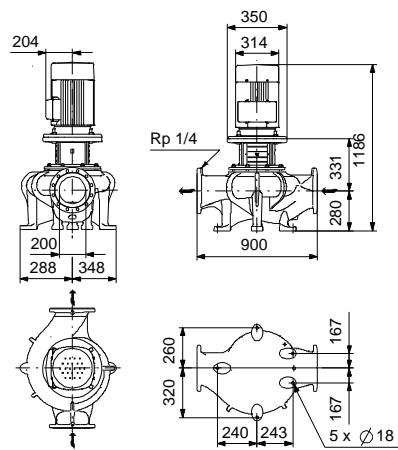
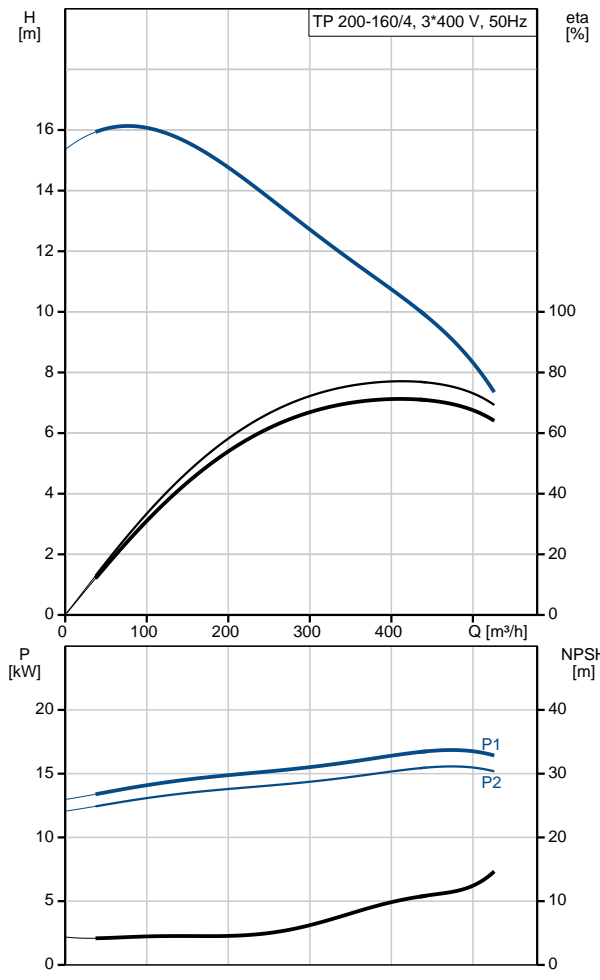

On request TP 200-160/4 A-F-A-BQQE 50 Hz

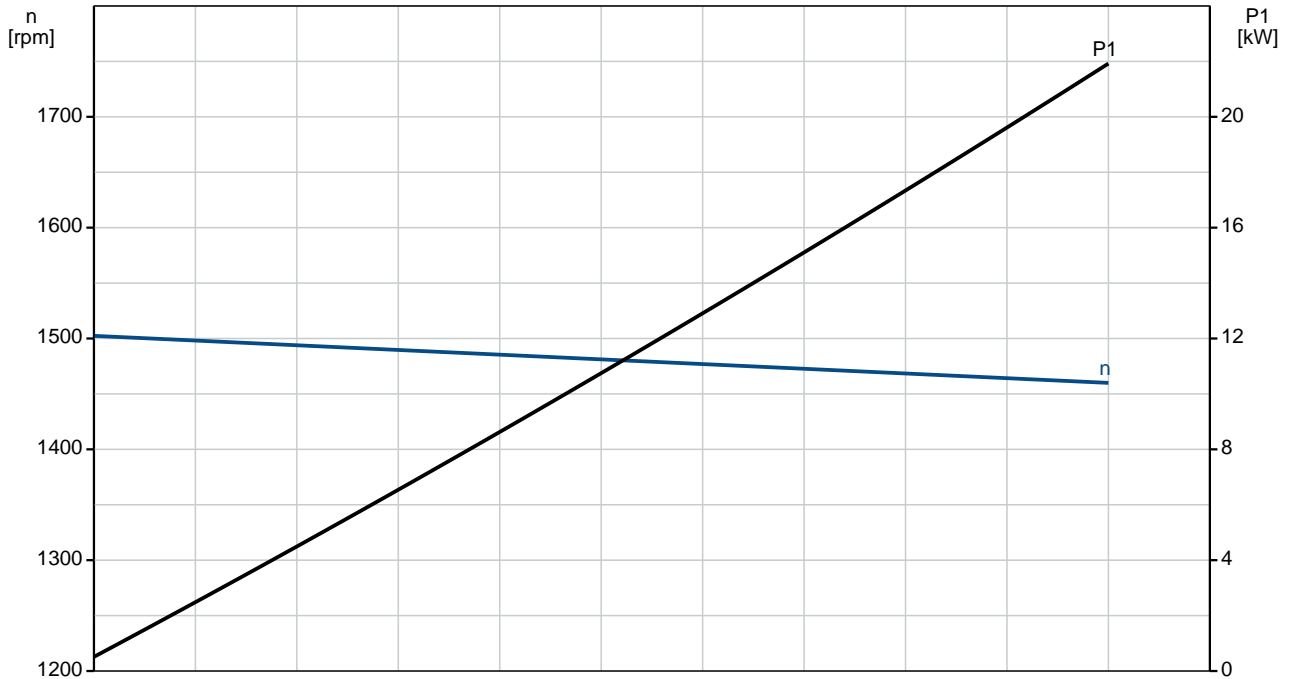
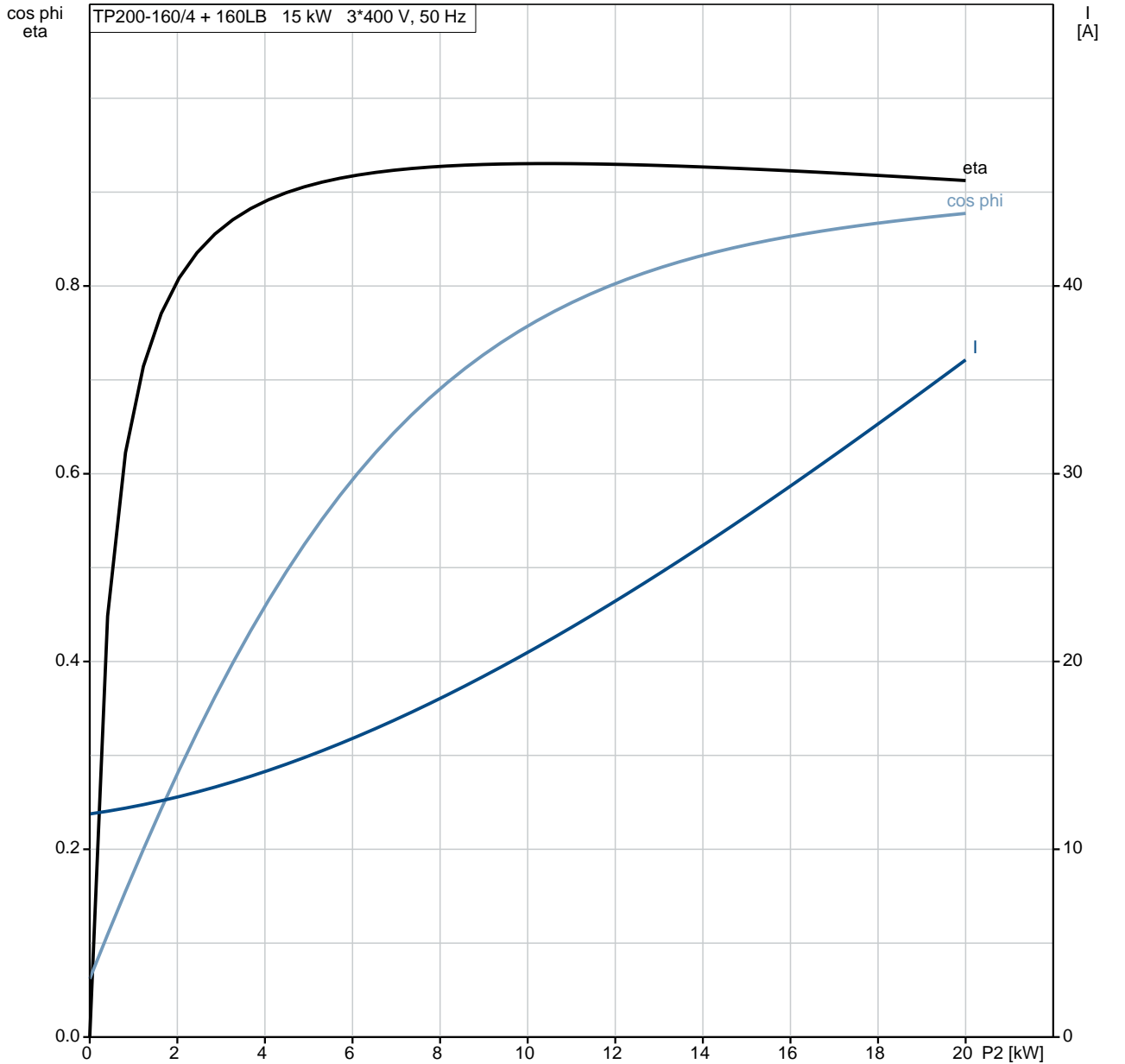

On request TP 200-160/4 A-F-A-BQQE 50 Hz

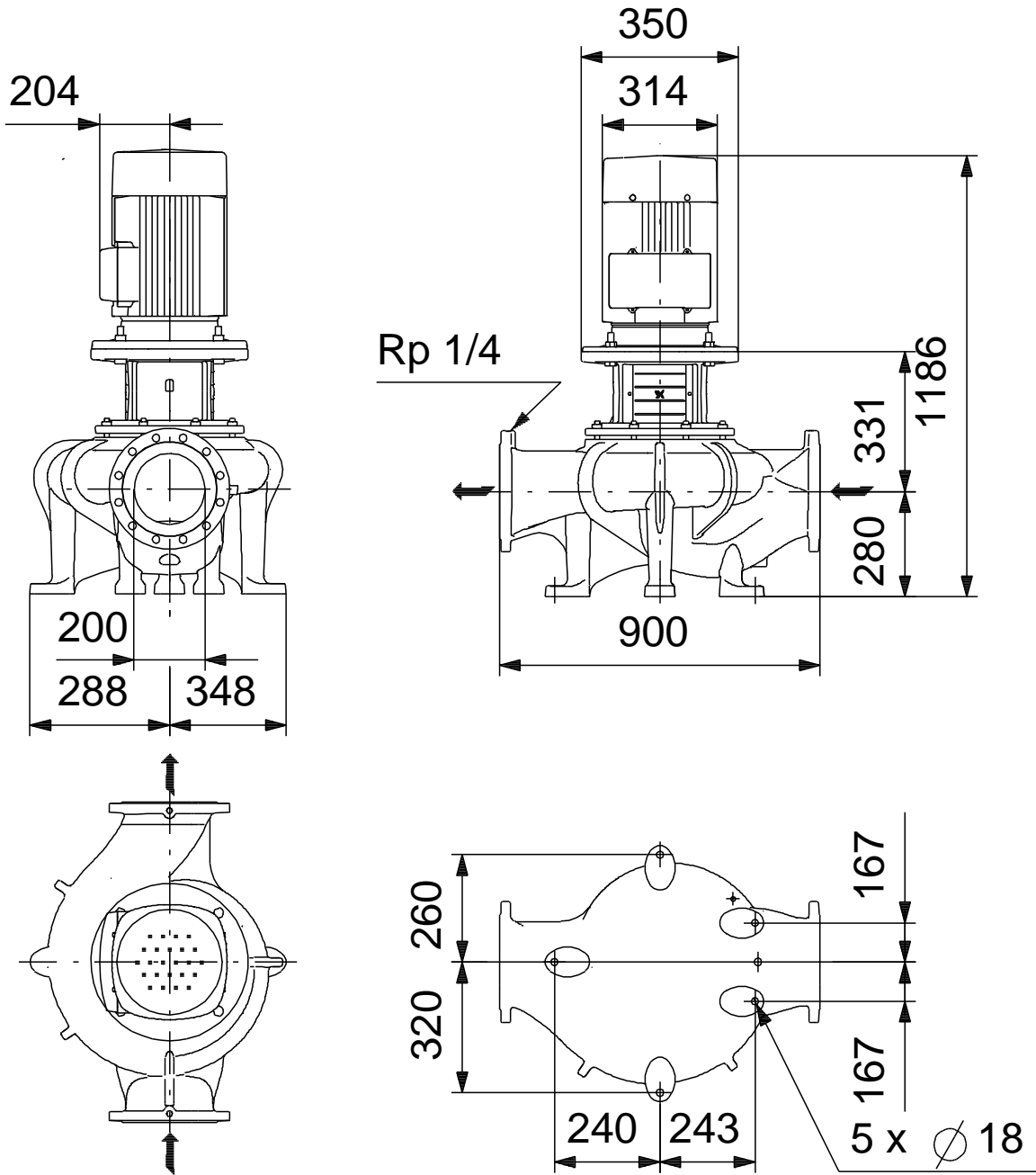

Note! All units are in [mm] unless others are stated.
Disclaimer: This simplified dimensional drawing does not show all details.

Exploded view

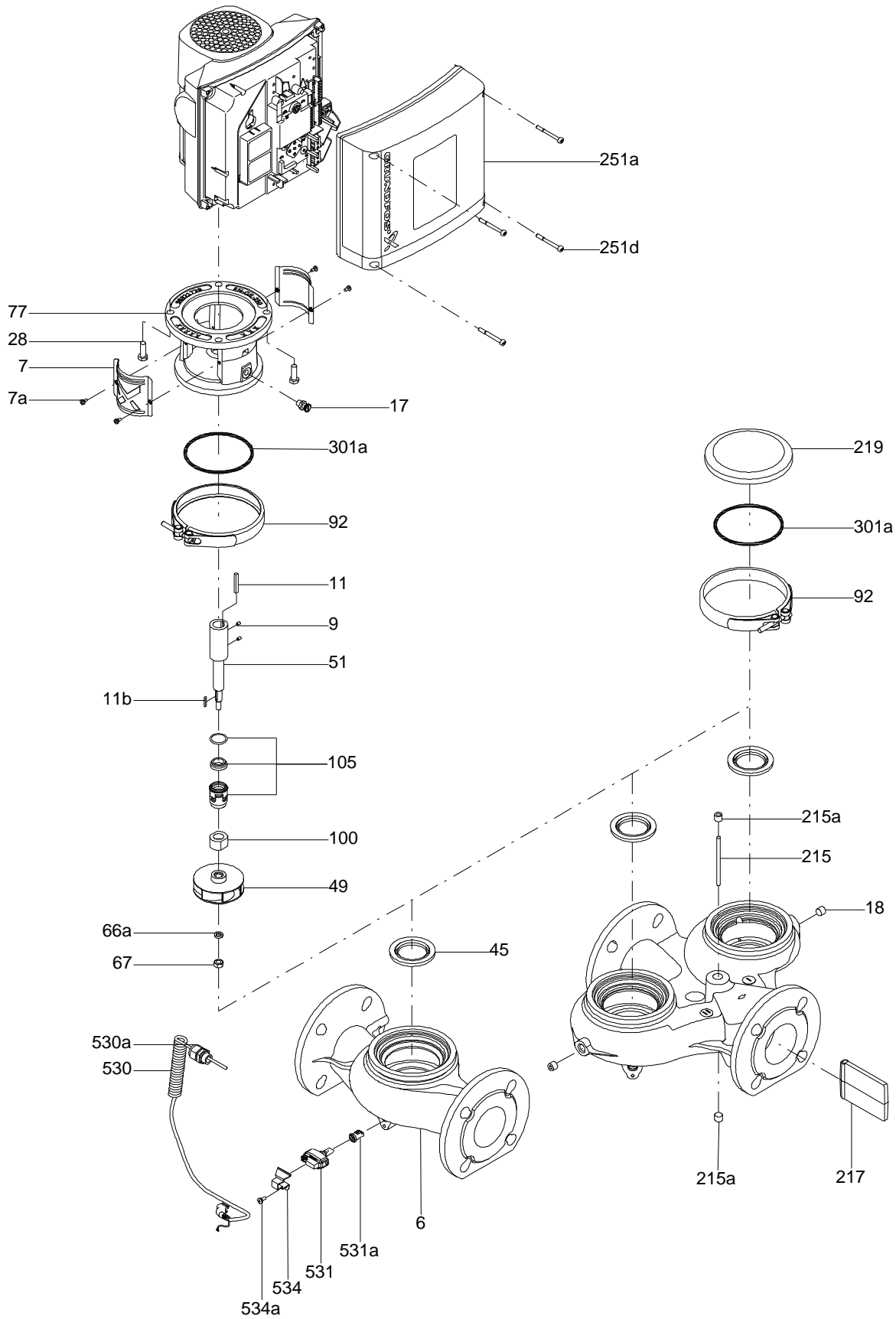

Sectional drawing (TM058200 for TPE2,TPE3)

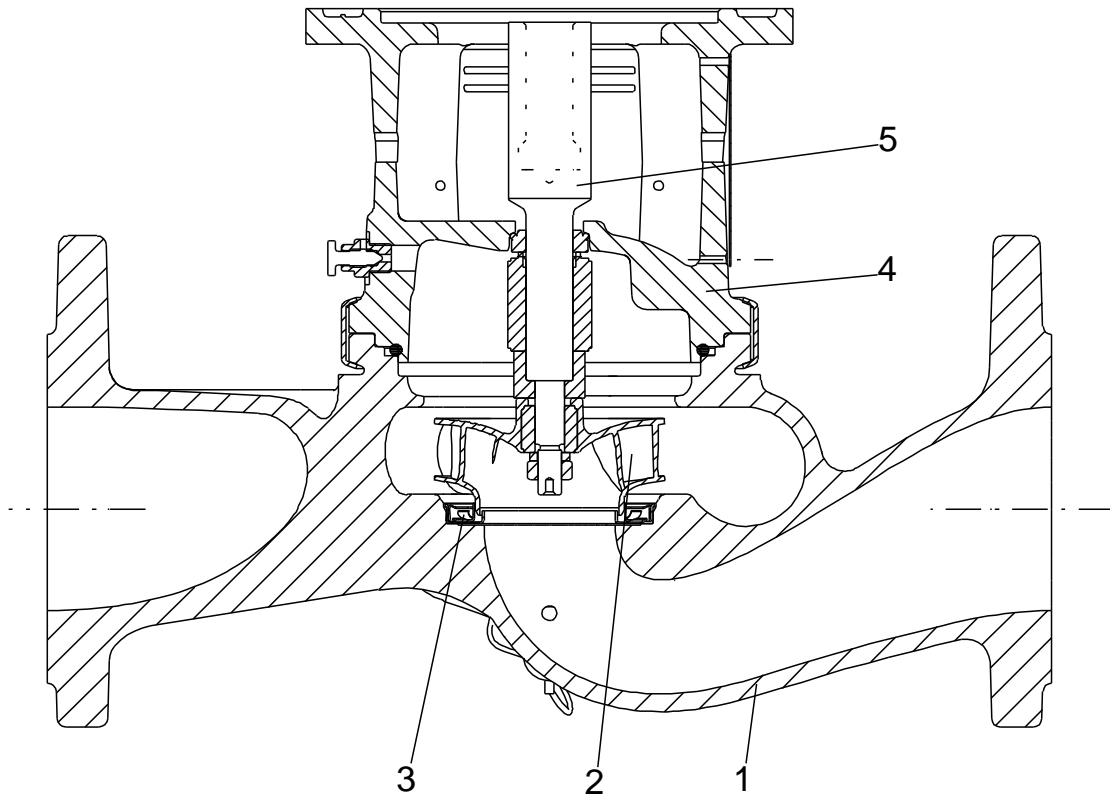

TM058200

Exploded view (TM057026 for MGE model H/I)

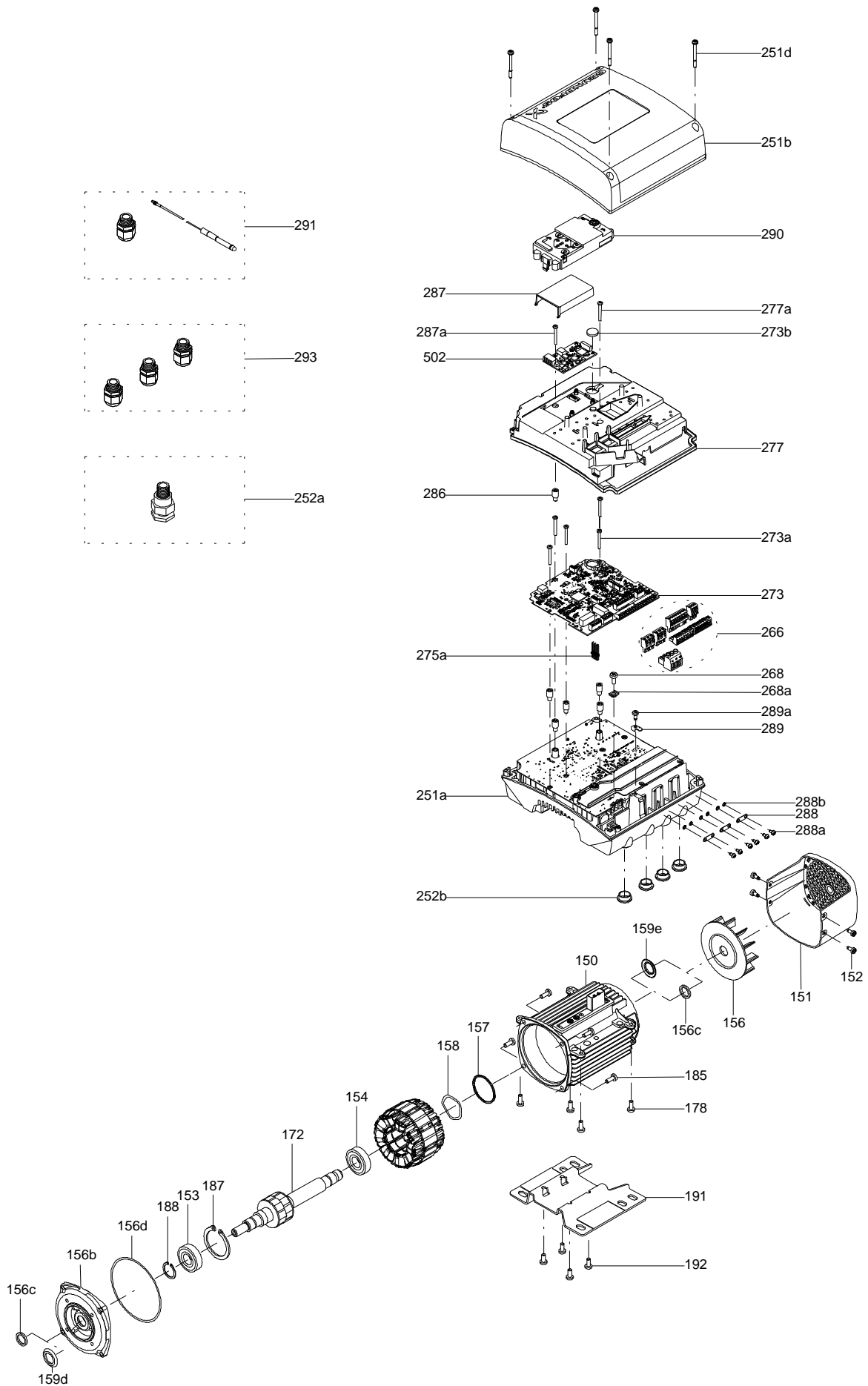

Parts list TP 200-160/4, Product No. On request
Valid from 1.1.2011 (1152)

Pos	Description	Annotation	Données de classification	Référence	Quantité	Unité
+	Motor				1	pcs
-	Nut				1	pcs
66	Washer				1	
66a	Spring lock washer				1	
67	Nut		Thread: M25		1	
-	Motor stool cpl.				1	pcs
1a	Motor stool				1	
7	Coupling guard				2	
77a	Pan head screw				4	
-	Pump housing cpl.				1	pcs
6	Pump housing				1	
66a	Nut		Thread: M12		10	
-	Shaft seal cpl.				1	pcs
72.a	O-ring		Diameter: 278,99 Material type: EPDM Thickness: 3,53		1	
105	Shaft seal				1	
-	Shaft cpl.				1	pcs
9	Socket set screw		Length (mm): 6 Thread: M8		2	
11	Key				1	
51	Stub shaft				1	
19	Plug				2	pcs
49	Impeller				1	pcs
-	77 Cover				1	pcs
77	Cover				1	

Disclaimer: The information about the Grundfos pump in this document may be outdated.

Data may be subject to alterations without further notice.

Please contact us to verify the data above is still accurate/up-to-date.

All information is copyright Grundfos.



info@lenntech.com

<https://www.lenntech.com>

tel. +31 152 610 900

fax. +31 152 616 289