

## MD.22.3.4 3x400V 10M Grundfos pump 97901100



Thank you for your interest in our products. Please contact us for more information, or visit our website

<https://www.lenntech.com/grundfos/MULDOUB/97901100/MD-22-3-4.html>

[info@lenntech.com](mailto:info@lenntech.com)

tel. +31 152 610 900

fax. +31 152 616 289

Position	Qty.	Description
	1	<p data-bbox="320 163 438 194"><b>MD.22.3.4</b></p>  <p data-bbox="711 595 1193 618" style="text-align: center;"><b>Note! Product picture may differ from actual product</b></p> <p data-bbox="320 629 600 651">Product No.: On request</p> <p data-bbox="320 689 1465 786">Supplied as complete unit ready for installation, the Multilift consist of a fully integrated collecting tank with two pumps and submersible motors, non-return valve with integrated Y-branch pipe, discharge adapter with flexible connection piece DN100 mounted on the collecting tank and a pre-wired Controller incl. a level sensor.</p> <p data-bbox="320 831 1417 882">The fully integrated collecting tank has all necessary ports for the connection of inlet pipe, discharge pipe, vent pipe and a manually operated diaphragm pump (accessory).</p> <p data-bbox="320 920 1465 1025">The collecting tank contains 8 inlet sockets around it's shape. The back inlet DN100 is placed on a patented inlet disk to connect all inlet pipe levels (centre) between 180 and 315mm stepless. DN100 and DN50 inlet sockets on each side. 2 x DN150, DN50 sockets on the top of the tank.</p> <p data-bbox="320 1093 1390 1144">Multilift corrosion free polyethylen collecting tanks are gas- and odour-proof as well as watertight , reduction of residual water and less sedimentation by chamfered bottom design.</p> <p data-bbox="320 1182 1465 1288">Pumps with Vortex impeller and a maintenance free submersible motors, oil chamber with physiological harmless oil filling between two shaft seals. Direction of rotation can be observed from outside over the shaft below the eye bolt.</p> <p data-bbox="320 1326 1426 1400">An LC221 controller with microprocessor is equipped with display for full monitoring possibilities. The pump and sensor are connected to the controller with 4m or 10m cable and tube length. The power supply cable is 1,5m with plug (incl. phase inverter for 3 phase motor)</p> <p data-bbox="320 1415 1437 1520">Contactless, piezo resistive pressure sensor pluggable inside the cabinet, monitored by controller, accurate to the millimetre shown on display. Blockage free pressure tube inside the tank without movable parts inside wastewater.</p> <p data-bbox="320 1588 1401 1639">The controller offer thermal motor protection and monitoring of pump operation. The thermal motor protection consists of thermal switches in the winding.</p> <p data-bbox="320 1677 544 1700">Controller functions:</p> <ul data-bbox="320 1704 1442 2085" style="list-style-type: none"> <li>• on/off, regular and failure changeover of two wastewater pumps based on a continuous signal from a piezo-resistive sensor</li> <li>• motor protection via motor-protective circuit breaker and/or current measurement as well as connection of thermal switches.</li> <li>• dry running motor protection via run-time limitation with a following emergency operation</li> <li>• 24h automatic test runs during long periods of inactivity</li> <li>• setting of delay times: <ul style="list-style-type: none"> <li>- stopping delay (time from the stop level is reached till the pumped is stopped)</li> <li>- starting delay (time from the start level is reached till the pumped is started)</li> <li>- alarm delay (time from a fault appears till an alarm is indicated) to prevents short-time high-level alarm in case of temporary high inflow to the tank.</li> </ul> </li> <li>• automatic current measurement for alarm indications</li> </ul>

Position	Qty.	Description
		<ul style="list-style-type: none"> <li>• operating indication of: <ul style="list-style-type: none"> <li>- operating mode (auto, manual)</li> <li>- operating hours</li> <li>- impulses (number of starts)</li> <li>- highest measured motor current</li> </ul> </li> <li>• alarm indication of: <ul style="list-style-type: none"> <li>- pump status (running, fault)</li> <li>- phase-sequence fault and missing phase</li> <li>- thermal-switch failure</li> <li>- high-water alarm</li> <li>- time for service/maintenance (selectable).</li> </ul> </li> <li>• selection of automatic alarm resetting</li> <li>• fault log of up to 20 alarms</li> <li>• selection between different start levels</li> <li>• selection of connected sensor type</li> <li>• calibration of sensor (preset)</li> <li>• selection of maintenance interval (0, 3, 6 or 12 months).</li> </ul> <p>As standard, the LC 221 has 6 potential-free outputs for:</p> <ul style="list-style-type: none"> <li>– pump running</li> <li>– pump failure</li> <li>– high water-level alarm</li> <li>– common fault.</li> </ul> <p>6 digital inputs for the following functions:</p> <ul style="list-style-type: none"> <li>– connecting a pressure sensor board (pre-assembled)</li> <li>– connecting an analogue sensor (4-20mA or 0-5V)</li> <li>– connecting up to four level switches or pressure switches instead of analogue sensor</li> <li>– connecting a separate level switch to be used for flood detection outside the Multilift. Lifting stations are often installed in a sump inside the basement - the lowest point in the building. In case of e.g. groundwater inflow or water pipe burst, an alarm will be indicated by the controller.</li> <li>– connecting an external alarm reset</li> <li>– connecting the thermal switch of the motor.</li> </ul> <p>The Multilift range is designed due to the standard EN12050-1, approved and monitored by external institute LGA. Further approvals are VDE, GHOST, CB, EMV</p> <p><b>Controls:</b> Type of control box: LC221.2</p> <p><b>Liquid:</b> Liquid temperature range: 0 °C .. 40 °C Density: 998.2 kg/m<sup>3</sup></p> <p><b>Technical:</b> Type of impeller: VORTEX Maximum particle size: 50 mm Approvals on nameplate: EN 12050-1 Valve type: FLAP VALVE</p> <p><b>Materials:</b> Impeller: LURANYL Tank: LDPE Gasket: NBR</p> <p><b>Installation:</b> Pump outlet: 80</p> <p><b>Electrical data:</b> Power input - P1: 2 x 3 kW Rated power - P2: 2 x 2.5 kW Mains frequency: 50 Hz Rated voltage: 3 x 400 V</p>

Position	Qty.	Description
		Voltage tolerance: +10/-14 % Max starts per. hour: 60 Rated current: 2 X 6,1 A Cos phi - power factor: 0.78 Rated speed: 1430 rpm Motor efficiency at full load: 80.8 % Number of poles: 4 Start. method: direct-on-line Enclosure class (IEC 34-5): IP68 Insulation class (IEC 85): F Type of cable plug: CEE 3P+N+E Mains cable: 1.5 m  <b>Tank:</b> Total volume of tank(s): 130 l Total effective volume of collecting tank at 180 mm inlet: 49 l Total effective volume of collecting tank at 250 mm inlet: 69 l Total effective volume of collecting tank at 315 mm inlet: 86 l  <b>Others:</b> Net weight: 121 kg

# On request MD.22.3.4 50 Hz

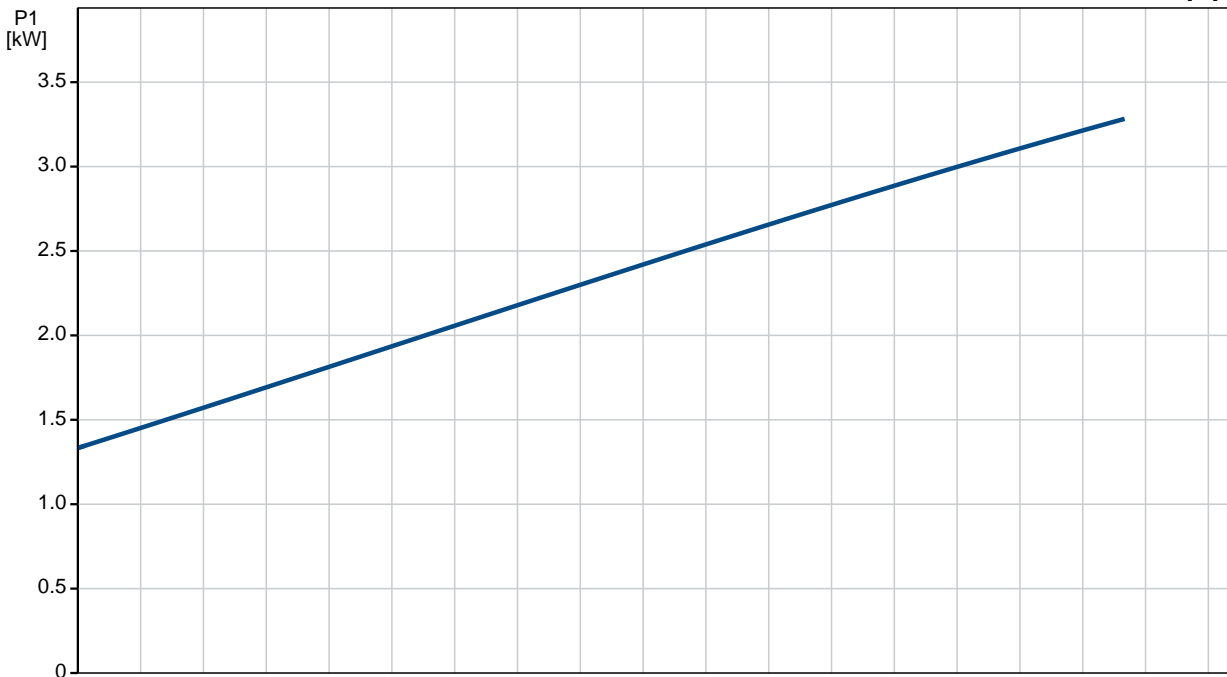
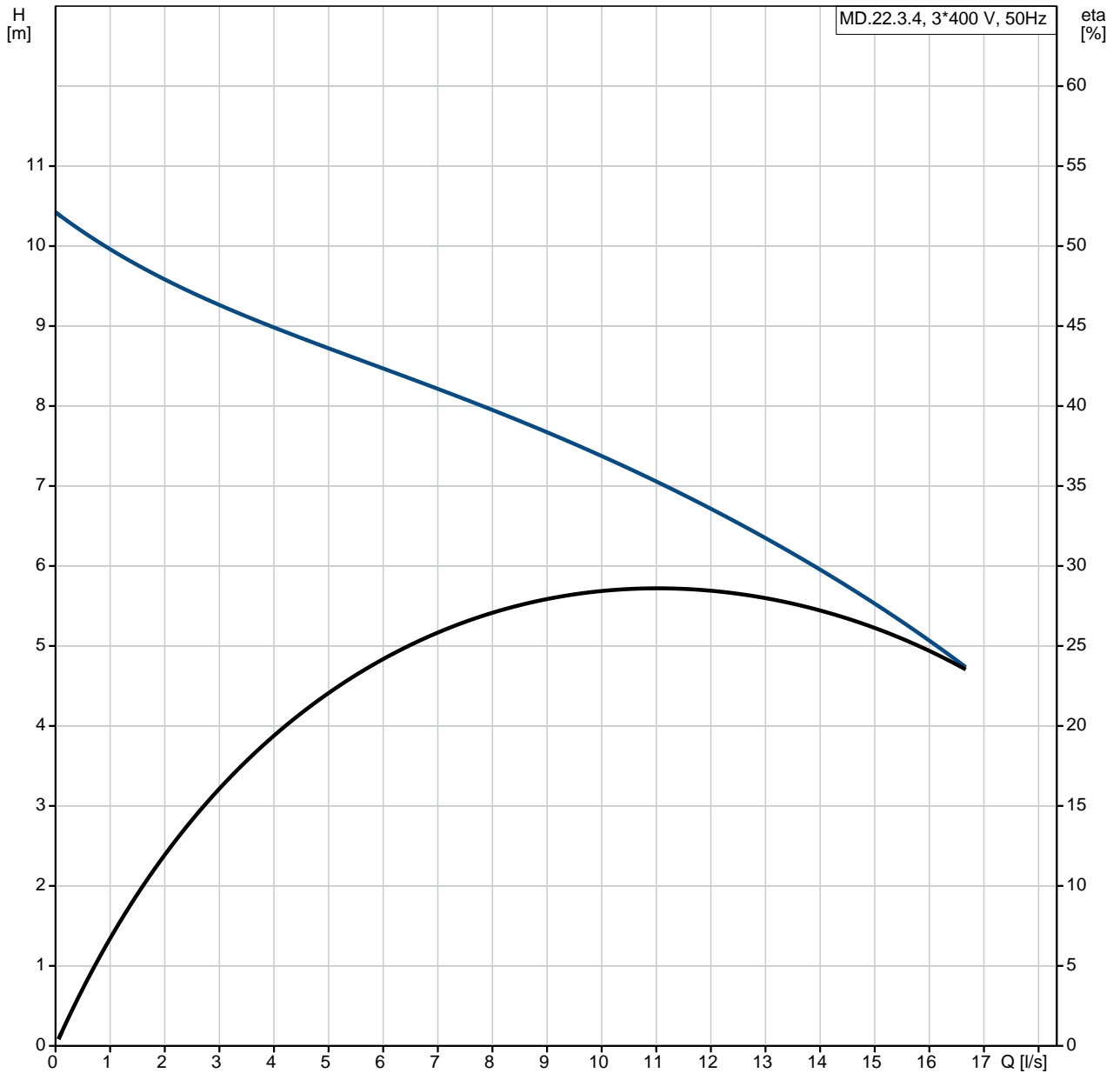

Description	Value
<b>General information:</b>	
Product name:	MD.22.3.4
Product No:	On request
EAN number:	On request
<b>Technical:</b>	
Max flow:	16.7 l/s
Head max:	10.4 m
Type of impeller:	VORTEX
Maximum particle size:	50 mm
Approvals on nameplate:	EN 12050-1
Valve type:	FLAP VALVE
<b>Materials:</b>	
Impeller:	LURANYL
Tank:	LDPE
Gasket:	NBR
<b>Installation:</b>	
Pump outlet:	80
<b>Liquid:</b>	
Liquid temperature range:	0 °C .. 40 °C
Density:	998.2 kg/m <sup>3</sup>
<b>Electrical data:</b>	
Power input - P1:	2 x 3 kW
Rated power - P2:	2 x 2.5 kW
Mains frequency:	50 Hz
Rated voltage:	3 x 400 V
Voltage tolerance:	+10/-14 %
Max starts per. hour:	60
Rated current:	2 X 6,1 A
Cos phi - power factor:	0.78
Rated speed:	1430 rpm
Motor efficiency at full load:	80.8 %
Number of poles:	4
Start. method:	direct-on-line
Enclosure class (IEC 34-5):	IP68
Insulation class (IEC 85):	F
Motor protec:	BIMETAL THERMAL SWITCH
Thermal protec:	BIMETAL THERMAL SWITCH
Motor cable:	10 m
Cable type:	H07 RN-F
Type of cable plug:	CEE 3P+N+E
Mains cable:	1.5 m
Cable size:	4X1,5+2X1
Mains cable:	H05 VV-F
<b>Controls:</b>	
Type of control box:	LC221.2
Operation mode:	S3-50%,1MIN
<b>Tank:</b>	
Total volume of tank(s):	130 l
Total effective volume of collecting tank at 180 mm inlet:	49 l
Total effective volume of collecting tank at 250 mm inlet:	69 l
Total effective volume of collecting tank at 315 mm inlet:	86 l
<b>Others:</b>	
Net weight:	121 kg

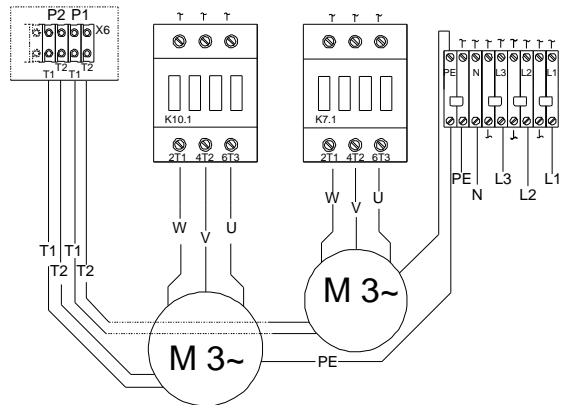
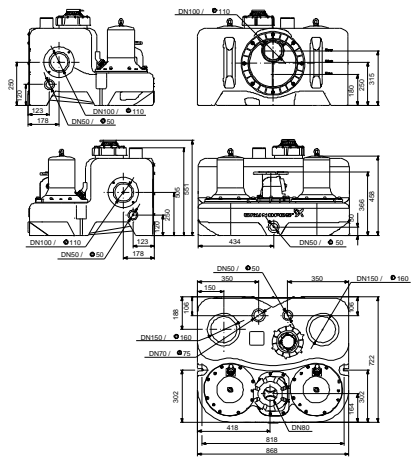
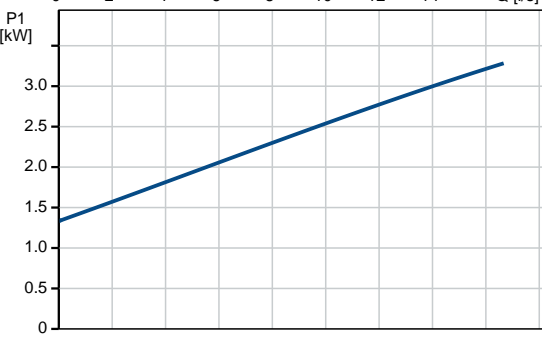
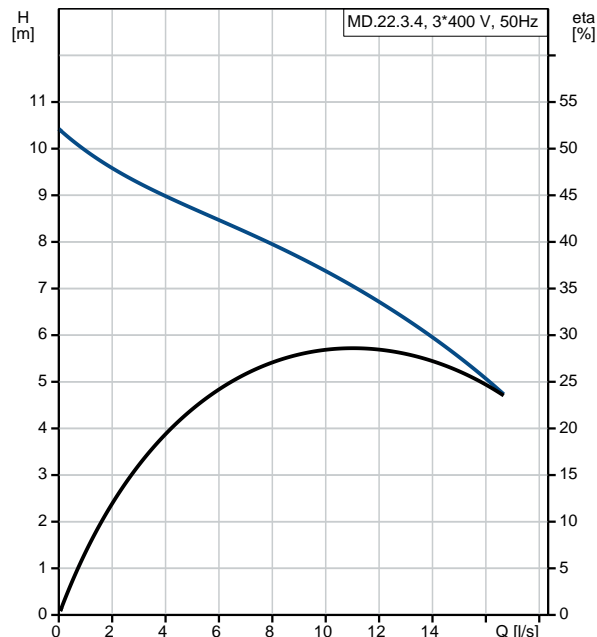

# On request MD.22.3.4 50 Hz

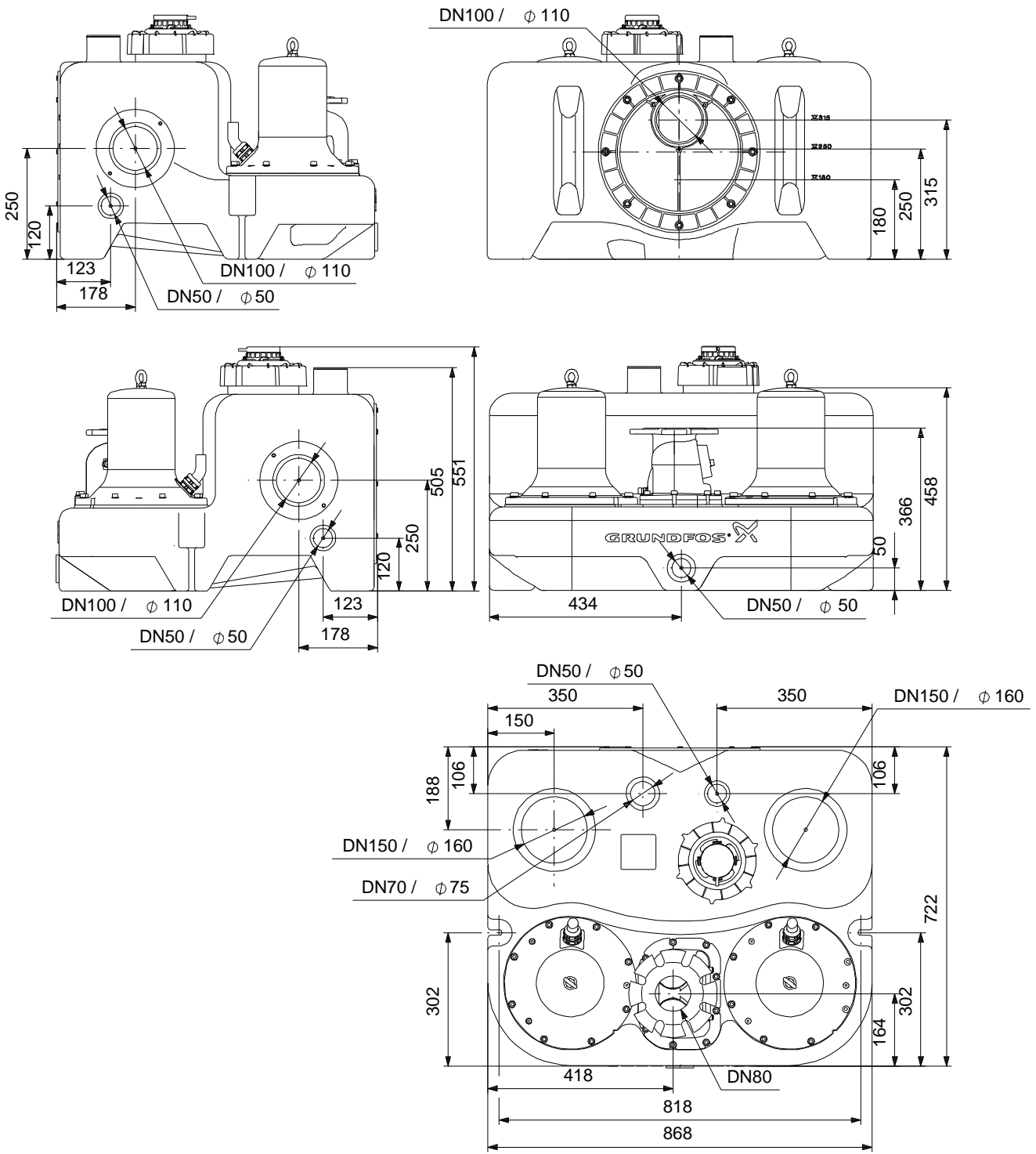

Note! All units are in [mm] unless others are stated.  
 Disclaimer: This simplified dimensional drawing does not show all details.

**Exploded view**

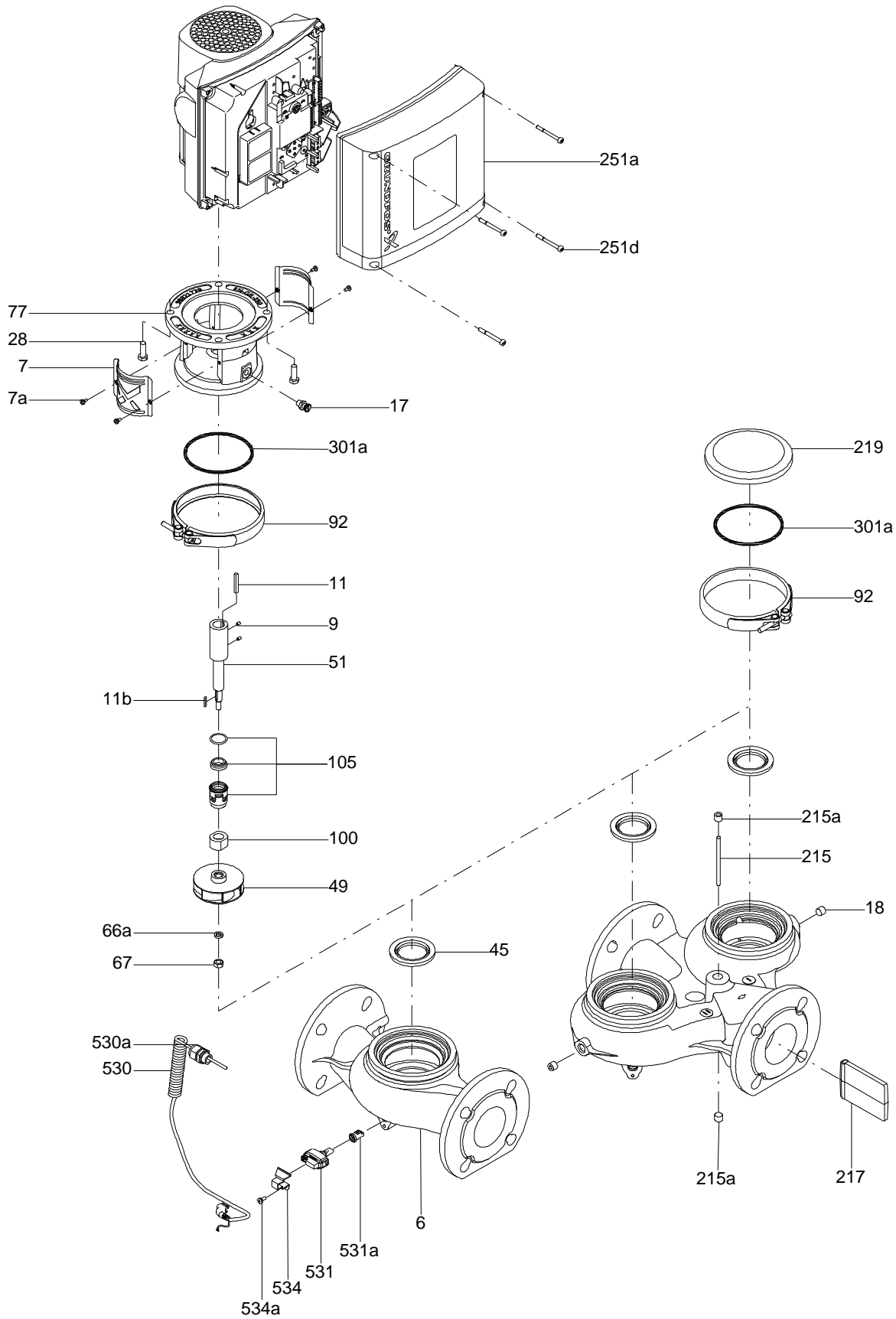



Sectional drawing (TM058200 for TPE2,TPE3)



TM058200

Exploded view ( TM057026 for MGE model H/I )

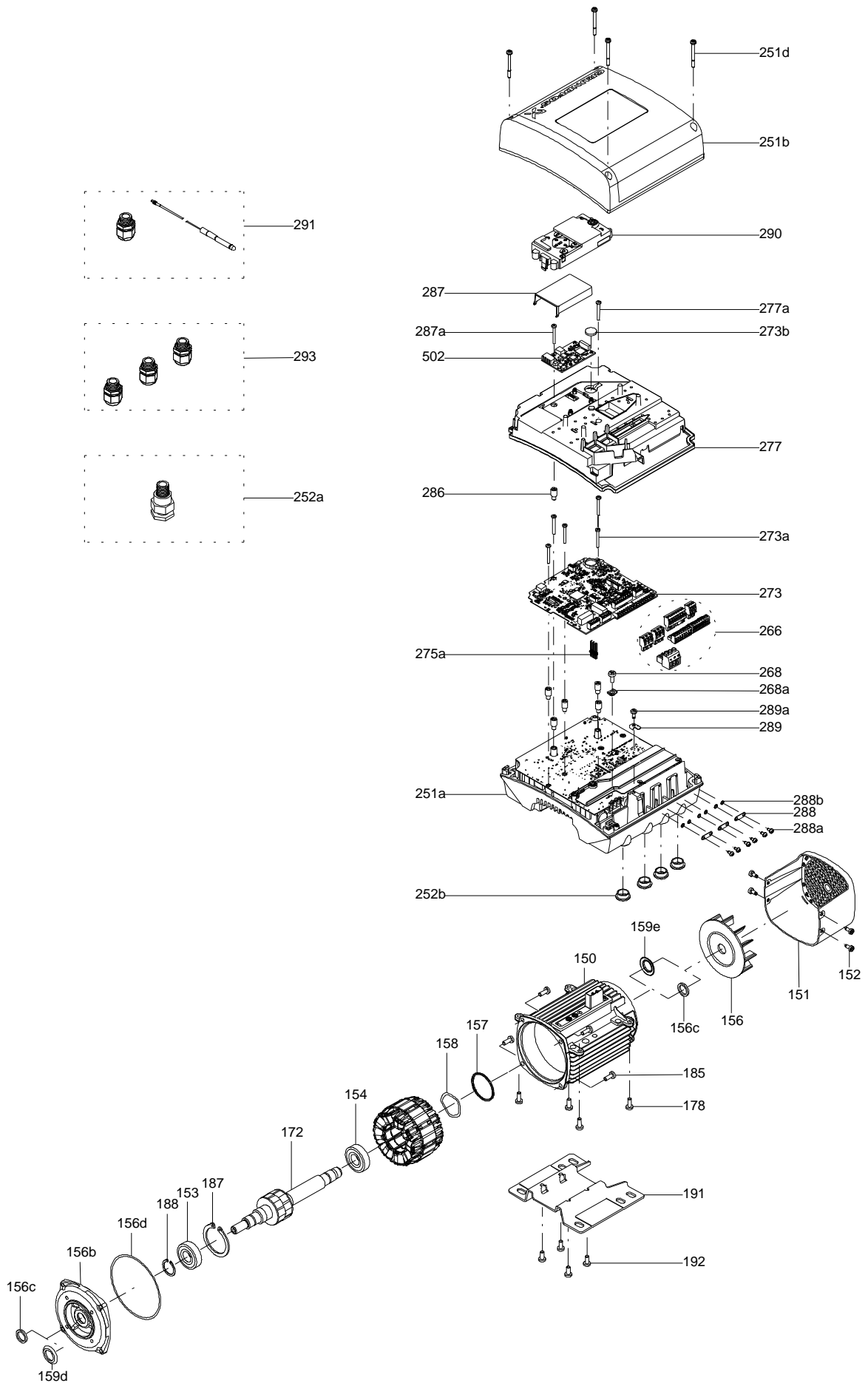

*Disclaimer: The information about the Grundfos pump in this document may be outdated.*

*Data may be subject to alterations without further notice.*

*Please contact us to verify the data above is still accurate/up-to-date.*

All information is copyright Grundfos.



[info@lenntech.com](mailto:info@lenntech.com)

<https://www.lenntech.com>

tel. +31 152 610 900

fax. +31 152 616 289