

CRI1S-15 A-P-I-E-HQQE 1x220/240 50HZ Grundfos pump 96562690



Thank you for your interest in our products. Please contact us for more information, or visit our website

<https://www.lenntech.com/grundfos/CRI1S/96562690/CRI-1S-15-A-P-I-E-HQQE.html>

info@lenntech.com

tel. +31 152 610 900

fax. +31 152 616 289

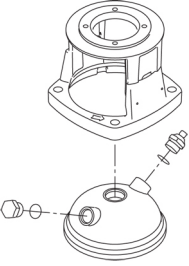
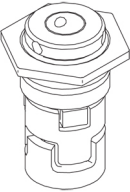
Position	Qty.	Description
	1	<p data-bbox="323 163 619 197">CRI 1S-15 A-P-A-E-HQQE</p>  <p data-bbox="323 483 600 517">Product No.: On request</p> <p data-bbox="323 546 1449 622">Vertical, multistage centrifugal pump with inlet and outlet ports on same the level (inline). Pump materials in contact with the liquid are in stainless steel. Power transmission is via a rigid split coupling. Pipe connection is via PJE (Victaulic®) couplings.</p> <p data-bbox="323 658 1054 692">The pump is fitted with a 1-phase, fan-cooled asynchronous motor.</p> <p data-bbox="323 719 639 752">Further product details</p> <p data-bbox="323 757 1449 857">Steel, cast iron and aluminium components have an epoxy-based coating made in a cathodic electro-deposition (CED) process. CED is a high-quality dip-painting process where an electrical field around the products ensures deposition of paint particles as a thin, well-controlled layer on the surface. An integral part of the process is a pretreatment. The entire process consists of these elements:</p> <ol data-bbox="323 869 815 987" style="list-style-type: none"> 1) Alkaline-based cleaning. 2) Zinc phosphating. 3) Cathodic electro-deposition. 4) Curing to a dry film thickness 18-22 my m. <p data-bbox="323 987 1027 1021">The colour code for the finished product is NCS 9000/RAL 9005.</p> <p data-bbox="323 1048 403 1081">Pump</p> <p data-bbox="323 1086 1449 1162">The pump head and flange for motor mounting is made in one piece (cast iron). The pump head cover is a separate component (stainless steel). The pump head has a combined 1/2" priming plug and vent screw.</p>  <p data-bbox="323 1462 1422 1563">The pump is fitted with a balanced O-ring seal unit with a rigid torque-transmission system. This seal type is assembled in a cartridge unit which makes replacement safe and easy. Due to the balancing, this seal type is suitable for high-pressure applications. The cartridge construction also protects the pump shaft from possible wear from a dynamic O-ring between pump shaft and shaft seal.</p> <p data-bbox="323 1574 467 1608">Primary seal:</p> <ul data-bbox="355 1608 919 1664" style="list-style-type: none"> • Rotating seal ring material: silicon carbide (SiC) • Stationary seat material: silicon carbide (SiC) <p data-bbox="323 1664 1422 1720">This material pairing is used where higher corrosion resistance is required. The high hardness of this material pairing offers good resistance against abrasive particles.</p> <p data-bbox="323 1720 986 1753">Secondary seal material: EPDM (ethylene-propylene rubber)</p> <p data-bbox="323 1753 1219 1787">EPDM has excellent resistance to hot water. EPDM is not suitable for mineral oils.</p>  <p data-bbox="323 2022 826 2056">The shaft seal is screwed into the pump head.</p>

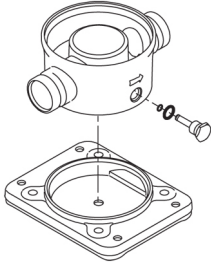
Position	Qty.	Description
		<p>The pump has a stainless-steel base mounted on a separate base plate. The base and base plate are kept in position by the tension of the staybolts which hold the pump together. The outlet side of the base has a combined drain plug and bypass valve. The pump is secured to the foundation by four bolts through the base plate. The base is prepared for connection by means of PJE (Victualic®) couplings.</p>  <p>Motor</p> <p>The motor is a totally enclosed, fan-cooled motor with principal dimensions to IEC and DIN standards. The motor is flange-mounted with tapped-hole flange (FT). Motor-mounting designation in accordance with IEC 60034-7: IM B 14 (Code I) / IM 3601 (Code II). Electrical tolerances comply with IEC 60034.</p> <p>The motor has built-in thermal protection (PTO current and temperature sensors) in accordance with IEC 60034-11 and requires no further motor protection. The protection reacts to both slow- and quick-rising temperatures, e.g. constant overload and stalled conditions.</p> <p>As the thermal protection incorporates automatic reset, the motor must be connected in a way which ensures that the automatic reset cannot cause accidents.</p> <p>Technical data</p> <p>Controls: Frequency converter: NONE</p> <p>Liquid: Pumped liquid: Water Liquid temperature range: -20 .. 120 °C Liquid temperature during operation: 20 °C Density: 998.2 kg/m³</p> <p>Technical: Rated flow: 0.9 m³/h Rated head: 64.1 m Pump orientation: Vertical Shaft seal arrangement: Single Code for shaft seal: HQQE Approvals on nameplate: CE, EAC, ACS Curve tolerance: ISO9906:2012 3B</p> <p>Materials: Base: Stainless steel EN 1.4408 AISI 316 Impeller: Stainless steel EN 1.4301 AISI 304 Bearing: SIC</p> <p>Installation: Maximum ambient temperature: 40 °C Maximum operating pressure: 25 bar Max pressure at stated temp: 25 bar / 120 °C 25 bar / -20 °C Type of connection: PJE Size of inlet connection: DN 32 1 1/4 inch Size of outlet connection: DN 32 1 1/4 inch</p>

Position	Qty.	Description
		Pressure rating for pipe connection: PN 50 Flange size for motor: FT100 Electrical data: Motor standard: IEC Motor type: 80A Rated power - P2: 0.55 kW Power (P2) required by pump: 0.55 kW Mains frequency: 50 Hz Rated voltage: 1 x 220-230/240 V Rated current: 4.00/3.65 A Starting current: 280 % Cos phi - power factor: 0.99 Rated speed: 2750 rpm Motor efficiency at full load: 66-64 % Number of poles: 2 Enclosure class (IEC 34-5): 55 Dust/Jetting Insulation class (IEC 85): F Others: Minimum efficiency index, MEI : 0.54 Net weight: 24.3 kg Gross weight: 27.2 kg Shipping volume: 0.074 m ³

On request CRI 1S-15 A-P-A-E-HQQE 50 Hz

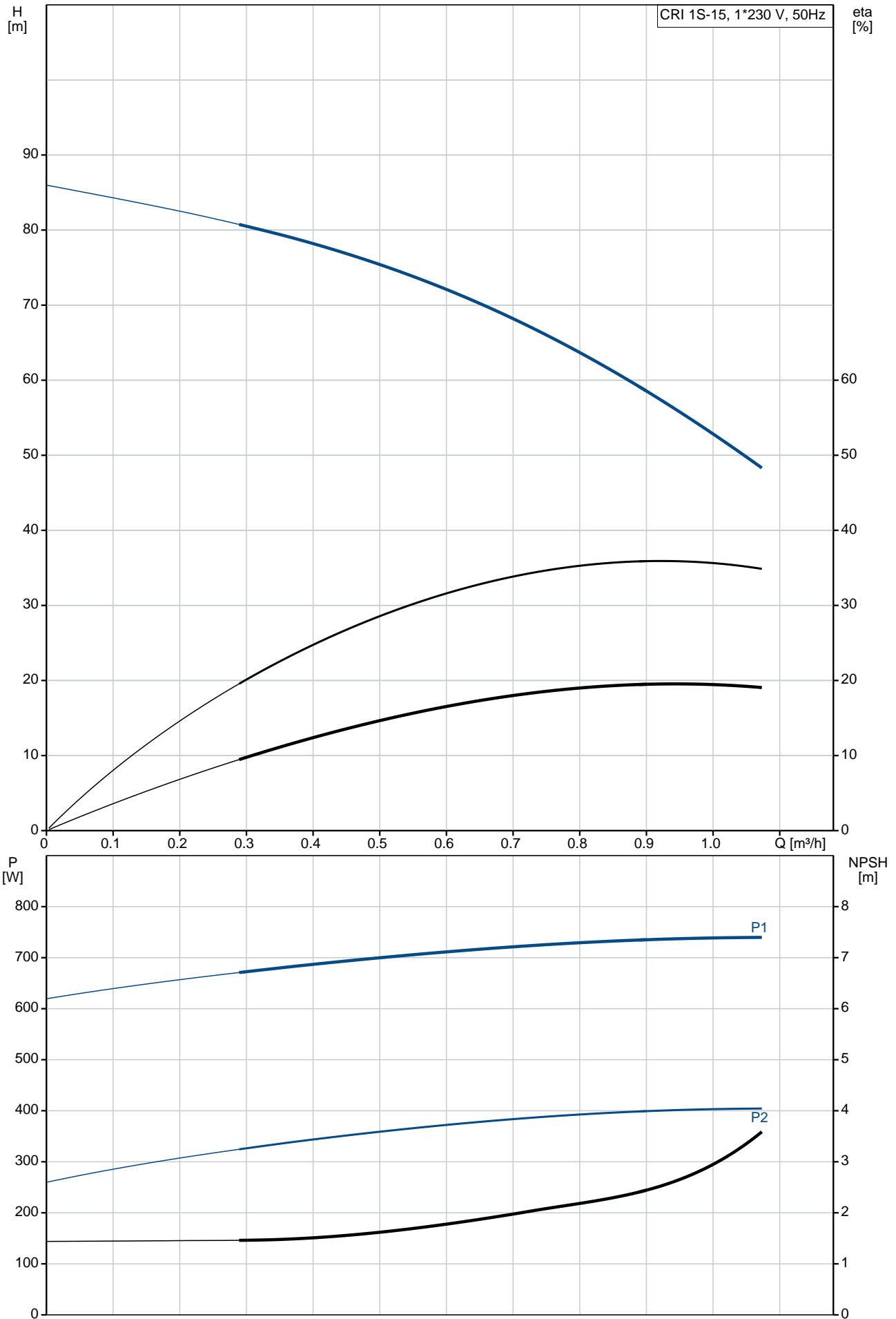

Description	Value
General information:	
Product name:	CRI 1S-15 A-P-A-E-HQQE
Product No:	On request
EAN number:	On request
Technical:	
Rated flow:	0.9 m ³ /h
Rated head:	64.1 m
Stages:	15
Impellers:	15
Number of reduced-diameter impellers:	0
Low NPSH:	N
Pump orientation:	Vertical
Shaft seal arrangement:	Single
Code for shaft seal:	HQQE
Approvals on nameplate:	CE, EAC, ACS
Curve tolerance:	ISO9906:2012 3B
Pump version:	A
Model:	A
Materials:	
Base:	Stainless steel EN 1.4408 AISI 316
Impeller:	Stainless steel EN 1.4301 AISI 304
Material code:	A
Code for rubber:	E
Bearing:	SIC
Installation:	
Maximum ambient temperature:	40 °C
Maximum operating pressure:	25 bar
Max pressure at stated temp:	25 bar / 120 °C 25 bar / -20 °C
Type of connection:	PJE
Size of inlet connection:	DN 32 1 1/4 inch
Size of outlet connection:	DN 32 1 1/4 inch
Pressure rating for pipe connection:	PN 50
Flange size for motor:	FT100
Connect code:	P
Liquid:	
Pumped liquid:	Water
Liquid temperature range:	-20 .. 120 °C
Liquid temperature during operation:	20 °C
Density:	998.2 kg/m ³
Electrical data:	
Motor standard:	IEC
Motor type:	80A
Rated power - P2:	0.55 kW
Power (P2) required by pump:	0.55 kW
Mains frequency:	50 Hz
Rated voltage:	1 x 220-230/240 V
Rated current:	4.00/3.65 A
Starting current:	280 %
Cos phi - power factor:	0.99
Rated speed:	2750 rpm
Motor efficiency at full load:	66-64 %
Number of poles:	2
Enclosure class (IEC 34-5):	55 Dust/Jetting
Insulation class (IEC 85):	F
Motor protec:	PTO
Motor No:	85215103

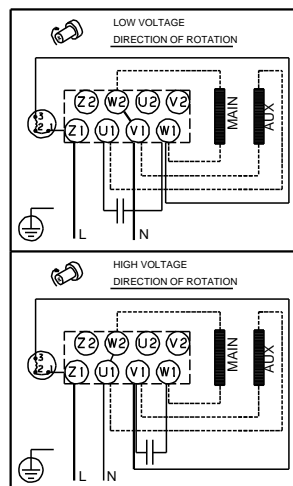
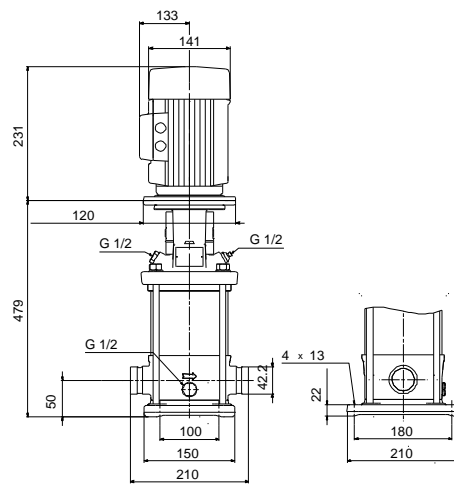
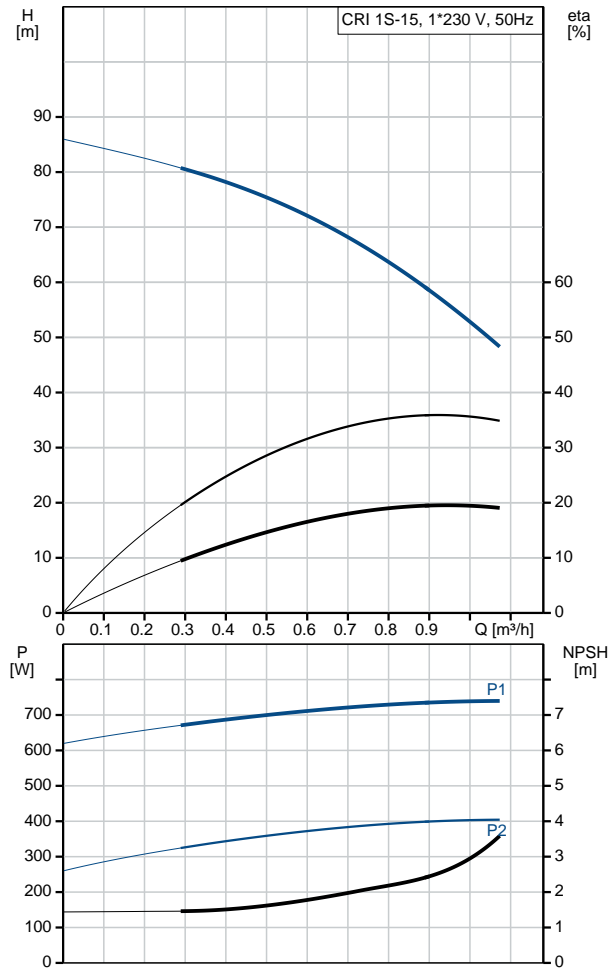

Description	Value
Controls:	
Frequency converter:	NONE
Others:	
Minimum efficiency index, MEI :	0.54
Net weight:	24.3 kg
Gross weight:	27.2 kg
Shipping volume:	0.074 m ³

On request CRI 1S-15 A-P-A-E-HQQE 50 Hz

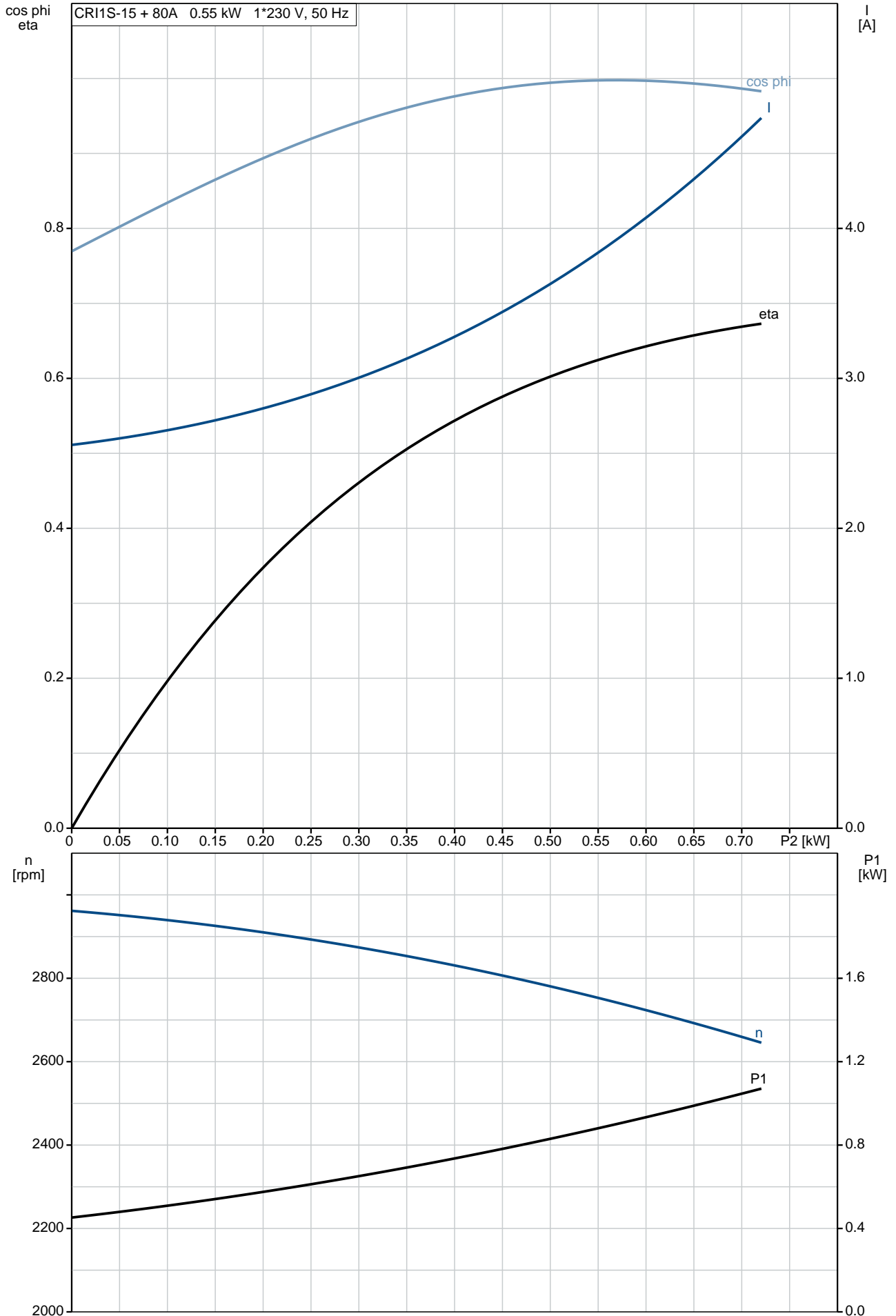

On request CRI 1S-15 A-P-A-E-HQQE 50 Hz

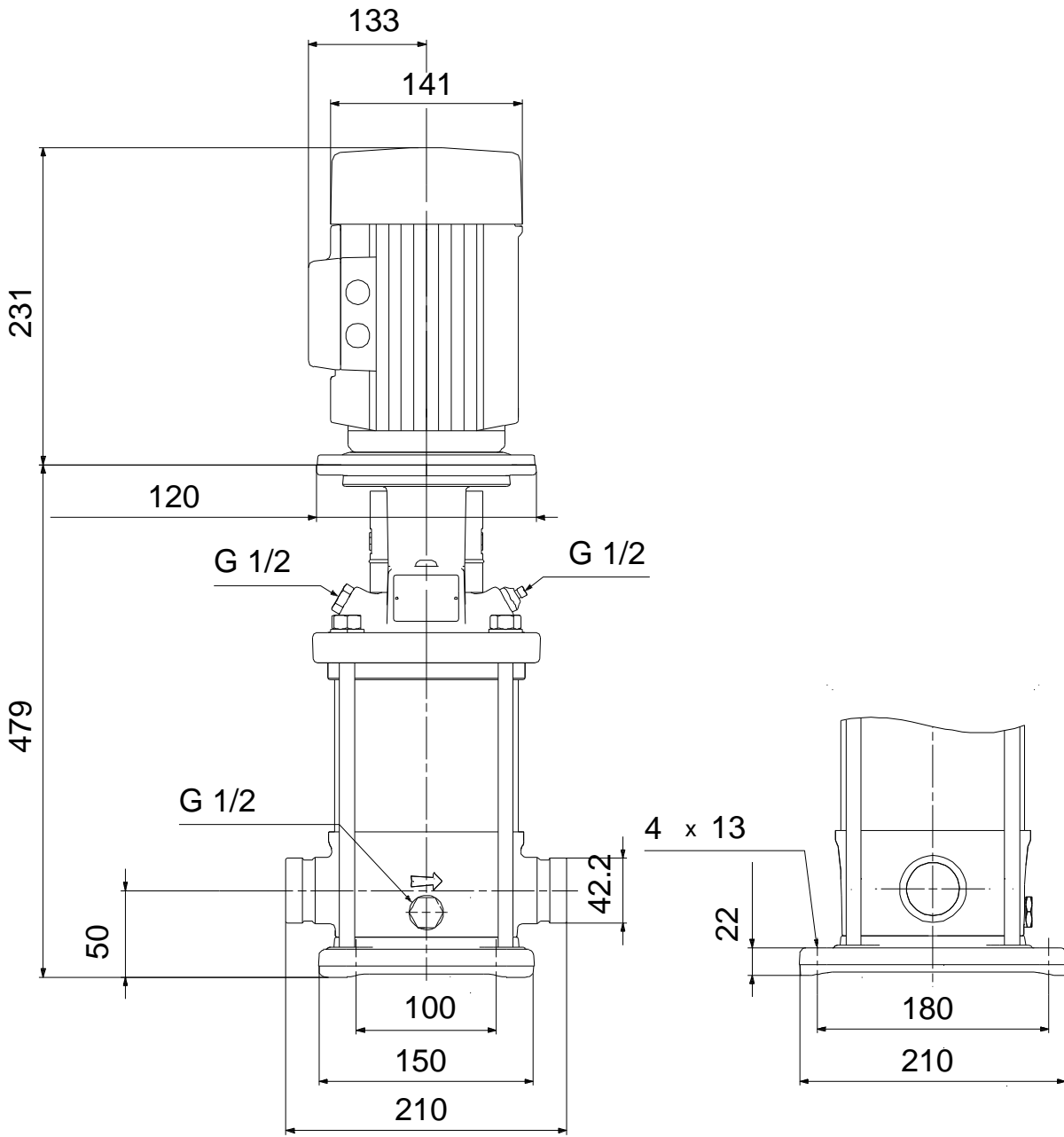

Note! All units are in [mm] unless others are stated.
Disclaimer: This simplified dimensional drawing does not show all details.

Exploded view

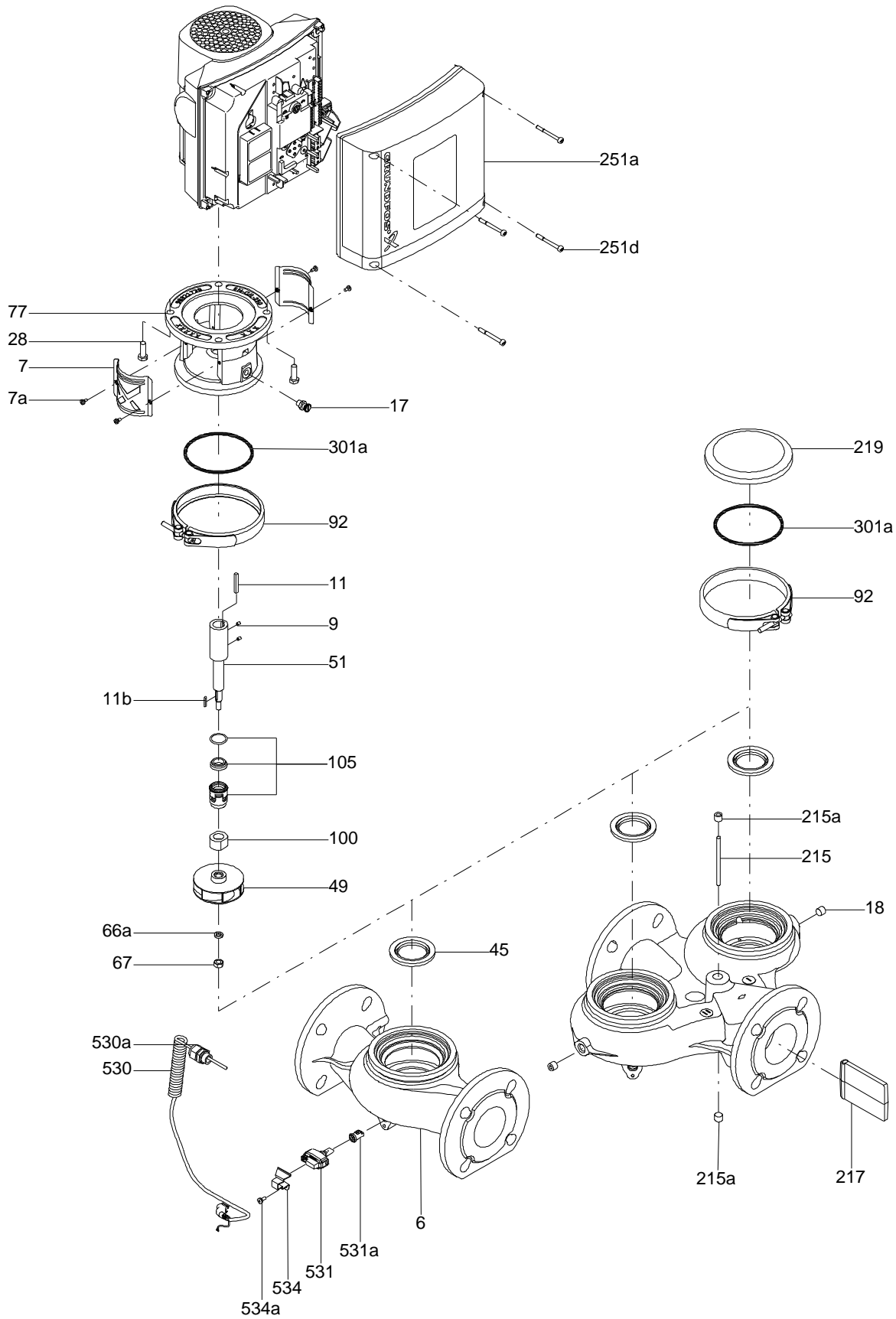

Sectional drawing (TM058200 for TPE2,TPE3)



TM058200

Exploded view (TM057026 for MGE model H/I)



Parts list CRI 1S-15, Product No. On request
Valid from 1.1.2004 (0401)

Pos	Description	Annotation	Données de classification	Référence	Quantité	Unité
+	Motor				1	pcs
-	Base cpl.				1	pcs
6	Base				1	
25	Plug				2	
56	Base plate				1	
-	Sealing parts				1	pcs
- 25	Drain plug w/bypass valve				1	
38	O-ring		Diameter: 16,3		1	
			Material type: EPDM			
			Thickness: 2,4			
37	O-ring				2	
100	O-ring		Diameter: 16,3		2	
			Material type: EPDM			
			Thickness: 2,4			
- 2	Pump head cpl.				1	pcs
2	Pump head				1	
7	Coupling guard				2	
7.a	Combi Slot Torx screw				4	
- 18	Air vent screw				1	
	Plug				1	
	Spindle				1	
23a	Plug				1	
28	Hex head screw		Length (mm): 25 MM		4	
			Thread: M6			
60	Formed wire spring				1	
77	Pump cover				1	
- 8	Coupling cpl.				1	pcs
9	Hex socket head cap screw		Designation: DIN 912		4	
			Length (mm): 20			
			Thread: M6			
10	Shaft pin		Diameter: 5		1	
			Length (mm): 26			
10a	Coupling half				2	
26	Staybolt		Length (mm): 367		4	pcs
			Thread: M12			
36a	Washer		Designation: DIN 125 A		4	pcs
			Internal diameter: 13			
			Outer diameter: 24			
			Thickness: 2,5			
55	Outer sleeve				1	pcs
66a	Nut		Thread: M12		4	pcs
- 80	Chamber stack				1	pcs
- 4	Chamber cpl.				12	
	Guide vane				6	
	Plate				1	
	Retainer				1	
	Intermediate chamber				1	
	Vane				1	
45	Neck ring				1	
65	Retainer				1	
- 4a	Chamber w. bearing cpl.				2	
	Guide vane				6	
	Retainer for bearing				1	
	Bearing bush				1	
	Retainer				1	
	Intermediate chamber				1	
	Vane				1	
45	Neck ring				1	
65	Retainer				1	

Pos	Description	Annotation	Données de classification	Référence	Quantité	Unité
- 5a	Chamber cpl.				1	
	Retainer				1	
	Intermediate chamber				1	
	Vane				1	
45	Neck ring				1	
65	Retainer				1	
36	Lock nut		Thread: M8		1	
47a	Bearing ring, rotating				2	
- 49	Impeller cpl.				15	
49	Impeller				1	
- 50a	Guide vane cpl.				1	
	Plate				1	
50a	Guide vane				6	
50b	Top plate				1	
- 51	Shaft, spline, cpl.				1	
51	Shaft				1	
62	Stop ring				1	
64a	Spacing pipe				12	
64a	Spacing pipe		Internal diameter: 12,85		2	
			Outer diameter: 15,85			
			Length (mm): 4,50			
64c	Clamp, splined		Internal diameter: 8,5		1	
			Outer diameter: 15			
66	Wedge lock washer				1	
- 105	Shaft seal		Material type: HQQE		1	pcs
	O-ring				1	
	O-ring				1	
	Seal driver, upper				1	
	Seal driver, lower				1	
	Spacer ring				1	
	Pipe				1	
	Plug				1	
	Plug				1	
	Compression spring				1	
	Socket set screw				1	
102	O-ring		Diameter: 22,00		1	
			Material type: EPDM			
			Thickness: 2,75			
103	Seal ring, stationary				1	
105	Seal ring, rotating				1	
107	O-ring				1	
113	Driver				1	

Disclaimer: The information about the Grundfos pump in this document may be outdated.

Data may be subject to alterations without further notice.

Please contact us to verify the data above is still accurate/up-to-date.

All information is copyright Grundfos.



info@lenntech.com

<https://www.lenntech.com>

tel. +31 152 610 900

fax. +31 152 616 289