

CRN1-2 A-CA-G-V-HQQV 3x230/400 50HZ

Grundfos pump 96520527



Thank you for your interest in our products. Please contact us for more information, or visit our website

<https://www.lenntech.com/grundfos/CRN01/96520527/CRN-1-2-A-CA-G-V-HQQV.html>

info@lenntech.com

tel. +31 152 610 900

fax. +31 152 616 289

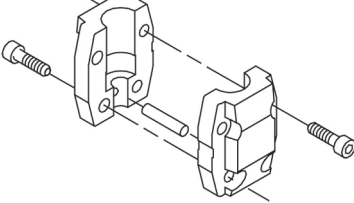
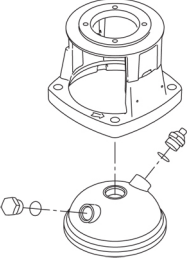
| Position | Qty. | Description |
|----------|------|--|
| | 1 | <p data-bbox="323 163 619 197">CRN 1-2 A-CA-A-V-HQQV</p>  <p data-bbox="323 488 598 521">Product No.: On request</p> <p data-bbox="323 548 1444 649">Vertical, multistage centrifugal pump with inlet and outlet ports on same the level (inline). Pump materials in contact with the liquid are in high-grade stainless steel. A cartridge shaft seal ensures high reliability, safe handling, and easy access and service. Power transmission is via a rigid split coupling. Pipe connection is via FlexiClamps.</p> <p data-bbox="323 689 1053 723">The pump is fitted with a 3-phase, fan-cooled asynchronous motor.</p> <p data-bbox="323 750 638 784">Further product details</p> <p data-bbox="323 788 1444 889">Steel, cast iron and aluminium components have an epoxy-based coating made in a cathodic electro-deposition (CED) process. CED is a high-quality dip-painting process where an electrical field around the products ensures deposition of paint particles as a thin, well-controlled layer on the surface. An integral part of the process is a pretreatment. The entire process consists of these elements:</p> <ol data-bbox="323 896 1029 1041" style="list-style-type: none"> 1) Alkaline-based cleaning. 2) Zinc phosphating. 3) Cathodic electro-deposition. 4) Curing to a dry film thickness 18-22 my m. <p data-bbox="323 1012 1029 1046">The colour code for the finished product is NCS 9000/RAL 9005.</p> <p data-bbox="323 1075 406 1108">Pump</p> <p data-bbox="323 1113 1412 1169">A standard split coupling connects the pump and motor shaft. It is enclosed in the pump head/motor stool by means of two coupling guards.</p>  <p data-bbox="323 1406 1444 1485">The pump head and flange for motor mounting is made in one piece (cast iron). The pump head cover is a separate component (stainless steel). The pump head has a combined 1/2" priming plug and vent screw.</p>  <p data-bbox="323 1787 1420 1888">The pump is fitted with a balanced O-ring seal unit with a rigid torque-transmission system. This seal type is assembled in a cartridge unit which makes replacement safe and easy. Due to the balancing, this seal type is suitable for high-pressure applications. The cartridge construction also protects the pump shaft from possible wear from a dynamic O-ring between pump shaft and shaft seal.</p> <p data-bbox="323 1899 470 1933">Primary seal:</p> <ul data-bbox="359 1926 917 1989" style="list-style-type: none"> • Rotating seal ring material: silicon carbide (SiC) • Stationary seat material: silicon carbide (SiC) <p data-bbox="323 1989 1428 2045">This material pairing is used where higher corrosion resistance is required. The high hardness of this material pairing offers good resistance against abrasive particles.</p> <p data-bbox="323 2045 893 2078">Secondary seal material: FKM (fluorocarbon rubber)</p> |

FKM has excellent resistance to oils and chemicals. Above 90 °C, FKM should only be used in media without water.

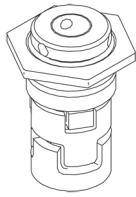

The shaft seal is screwed into the pump head.

The chambers and impellers are made of stainless-steel sheet. The chambers are provided with a PTFE neck ring offering improved sealing and high efficiency. The impellers have smooth surfaces, and the shape of the blades ensure a high efficiency.

The pump has a stainless-steel base mounted on a separate base plate. The base and base plate are kept in position by the tension of the staybolts which hold the pump together. The outlet side of the base has a combined drain plug and bypass valve. The pump is secured to the foundation by four bolts through the base plate. The base is prepared for connection by means of FlexiClamp couplings.

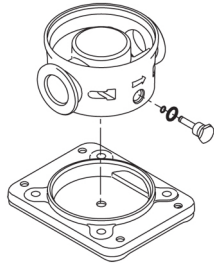

Motor

The motor is a totally enclosed, fan-cooled motor with principal dimensions to IEC and DIN standards. The motor is flange-mounted with tapped-hole flange (FT).

Motor-mounting designation in accordance with IEC 60034-7: IM B 14 (Code I) / IM 3601 (Code II).

Electrical tolerances comply with IEC 60034.

The motor efficiency is classified as IE3 in accordance with IEC 60034-30-1.

The motor does not incorporate motor protection and must be connected to a motor-protective circuit breaker which can be manually reset. The motor-protective circuit breaker must be set according to the rated current of the motor (I1/1).

Technical data

Controls:

Frequency converter: NONE

Liquid:

Pumped liquid: Water
Liquid temperature range: -20 .. 90 °C
Liquid temperature during operation: 20 °C
Density: 998.2 kg/m³

Technical:

Rated flow: 1.8 m³/h
Rated head: 9.8 m
Pump orientation: Vertical
Shaft seal arrangement: Single
Code for shaft seal: HQQV
Approvals on nameplate: CE, EAC
Curve tolerance: ISO9906:2012 3B

Materials:

Base: Stainless steel
EN 1.4408
AISI 316

| Position | Qty. | Description |
|----------|------|---|
| | | <p>Impeller: Stainless steel EN 1.4401 AISI 316</p> <p>Bearing: SIC</p> <p>Installation: Maximum ambient temperature: 40 °C Maximum operating pressure: 25 bar Max pressure at stated temp: 25 bar / 90 °C 25 bar / -20 °C</p> <p>Type of connection: FlexiClamp Size of inlet connection: DN 32 1 1/4 inch</p> <p>Size of outlet connection: DN 32 1 1/4 inch</p> <p>Pressure rating for pipe connection: PN 25 Flange size for motor: FT85</p> <p>Electrical data: Motor standard: IEC Motor type: 71A IE Efficiency class: IE3 Rated power - P2: 0.37 kW Power (P2) required by pump: 0.37 kW Mains frequency: 50 Hz Rated voltage: 3 x 220-240D/380-415Y V Rated current: 1.74/1.00 A Starting current: 490-530 % Cos phi - power factor: 0.80-0.70 Rated speed: 2850-2880 rpm Efficiency: IE3 73,8% Motor efficiency at full load: 73.8 % Motor efficiency at 3/4 load: 79.0 % Motor efficiency at 1/2 load: 75.5 % Number of poles: 2 Enclosure class (IEC 34-5): 55 Dust/Jetting Insulation class (IEC 85): F</p> <p>Others: Minimum efficiency index, MEI : 0.7 Net weight: 16.5 kg Gross weight: 19.1 kg Shipping volume: 0.054 m³</p> |

On request CRN 1-2 A-CA-A-V-HQQV 50 Hz

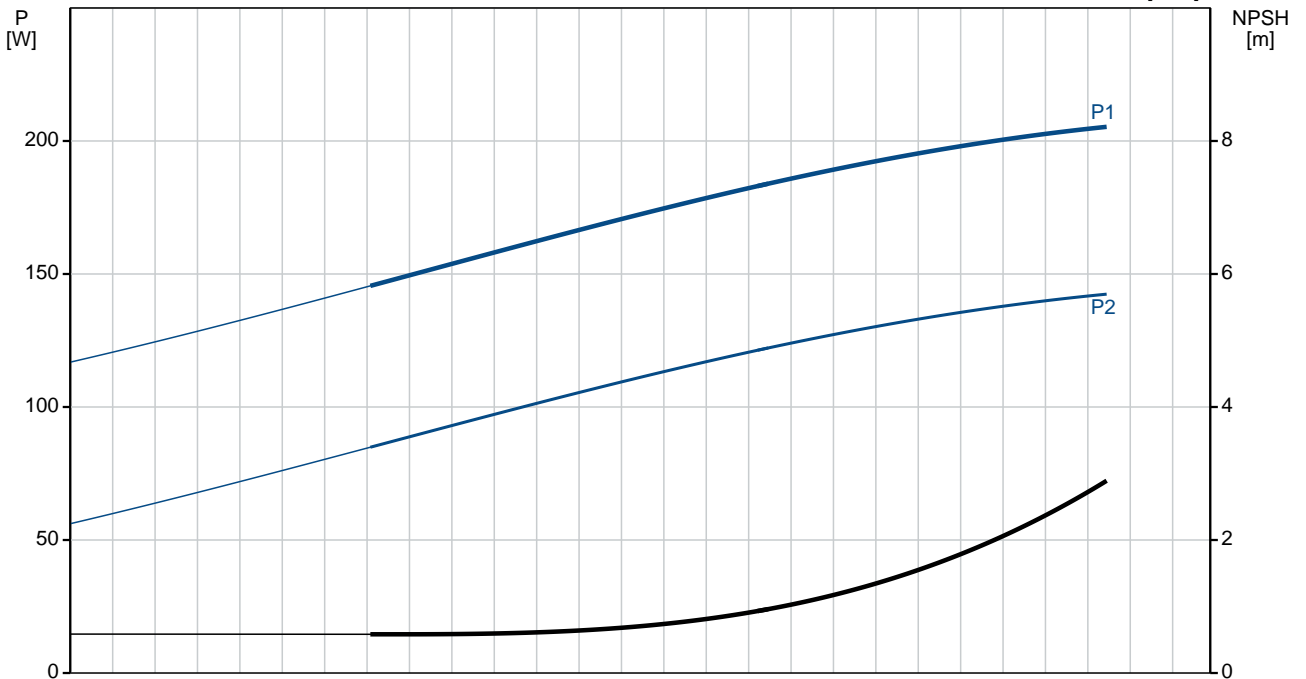
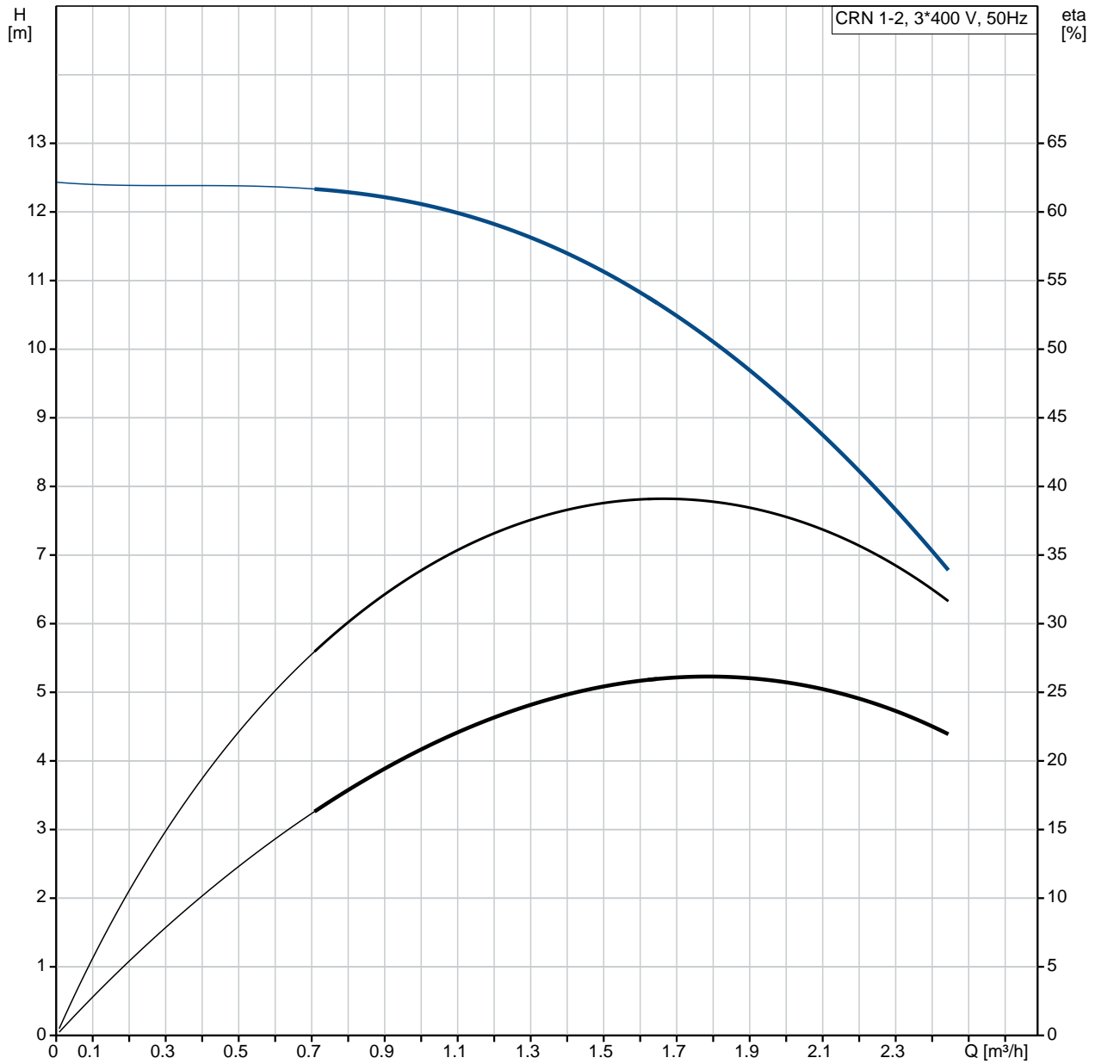

| Description | Value |
|---------------------------------------|--|
| General information: | |
| Product name: | CRN 1-2 A-CA-A-V-HQQV |
| Product No: | On request |
| EAN number: | On request |
| Technical: | |
| Rated flow: | 1.8 m ³ /h |
| Rated head: | 9.8 m |
| Stages: | 3 |
| Impellers: | 2 |
| Number of reduced-diameter impellers: | 0 |
| Low NPSH: | N |
| Pump orientation: | Vertical |
| Shaft seal arrangement: | Single |
| Code for shaft seal: | HQQV |
| Approvals on nameplate: | CE, EAC |
| Curve tolerance: | ISO9906:2012 3B |
| Pump version: | A |
| Model: | A |
| Materials: | |
| Base: | Stainless steel EN 1.4408 AISI 316 |
| Impeller: | Stainless steel EN 1.4401 AISI 316 |
| Material code: | A |
| Code for rubber: | V |
| Bearing: | SIC |
| Installation: | |
| Maximum ambient temperature: | 40 °C |
| Maximum operating pressure: | 25 bar |
| Max pressure at stated temp: | 25 bar / 90 °C 25 bar / -20 °C |
| Type of connection: | FlexiClamp |
| Size of inlet connection: | DN 32 1 1/4 inch |
| Size of outlet connection: | DN 32 1 1/4 inch |
| Pressure rating for pipe connection: | PN 25 |
| Flange size for motor: | FT85 |
| Connect code: | CA |
| Liquid: | |
| Pumped liquid: | Water |
| Liquid temperature range: | -20 .. 90 °C |
| Liquid temperature during operation: | 20 °C |
| Density: | 998.2 kg/m ³ |
| Electrical data: | |
| Motor standard: | IEC |
| Motor type: | 71A |
| IE Efficiency class: | IE3 |
| Rated power - P2: | 0.37 kW |
| Power (P2) required by pump: | 0.37 kW |
| Mains frequency: | 50 Hz |
| Rated voltage: | 3 x 220-240D/380-415Y V |
| Rated current: | 1.74/1.00 A |
| Starting current: | 490-530 % |
| Cos phi - power factor: | 0.80-0.70 |
| Rated speed: | 2850-2880 rpm |
| Efficiency: | IE3 73.8% |
| Motor efficiency at full load: | 73.8 % |
| Motor efficiency at 3/4 load: | 79.0 % |
| Motor efficiency at 1/2 load: | 75.5 % |
| Number of poles: | 2 |

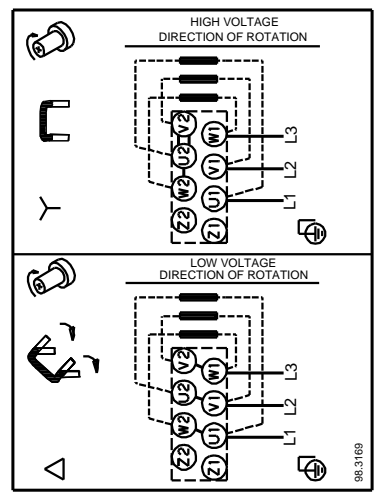
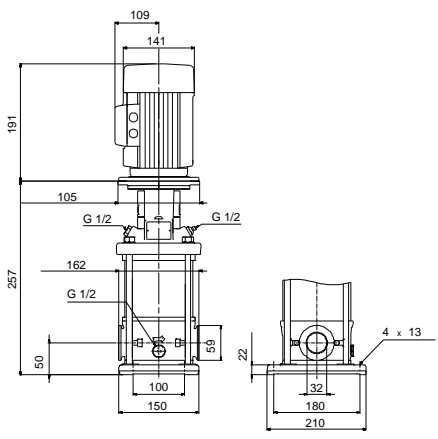
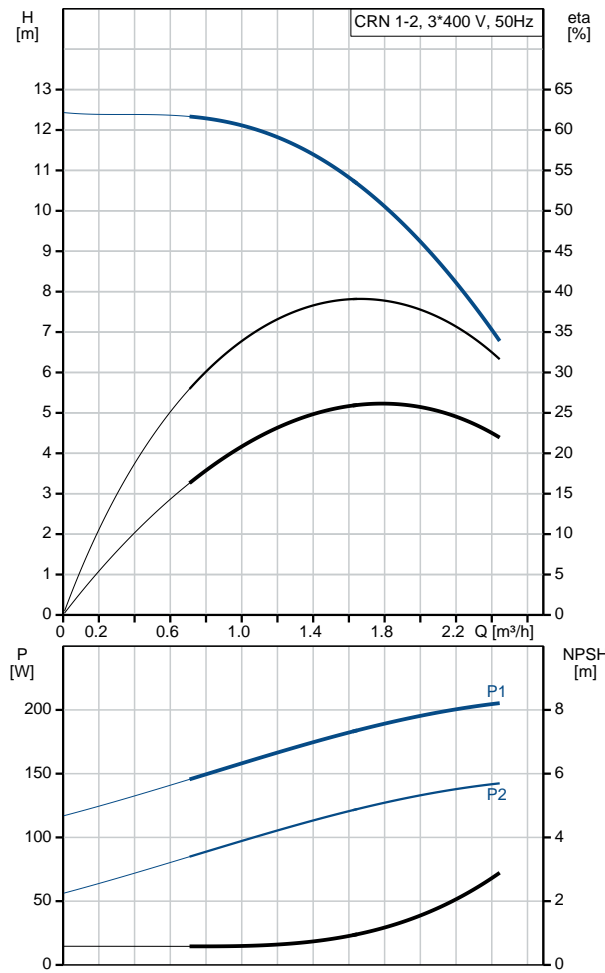

| Description | Value |
|---------------------------------|----------------------|
| Enclosure class (IEC 34-5): | 55 Dust/Jetting |
| Insulation class (IEC 85): | F |
| Motor protec: | NONE |
| Motor No: | 85805102 |
| Controls: | |
| Frequency converter: | NONE |
| Others: | |
| Minimum efficiency index, MEI : | 0.7 |
| Net weight: | 16.5 kg |
| Gross weight: | 19.1 kg |
| Shipping volume: | 0.054 m ³ |

On request CRN 1-2 A-CA-A-V-HQQV 50 Hz

CRN1-2 + 71A 0.37 kW 3*400 V, 50 Hz

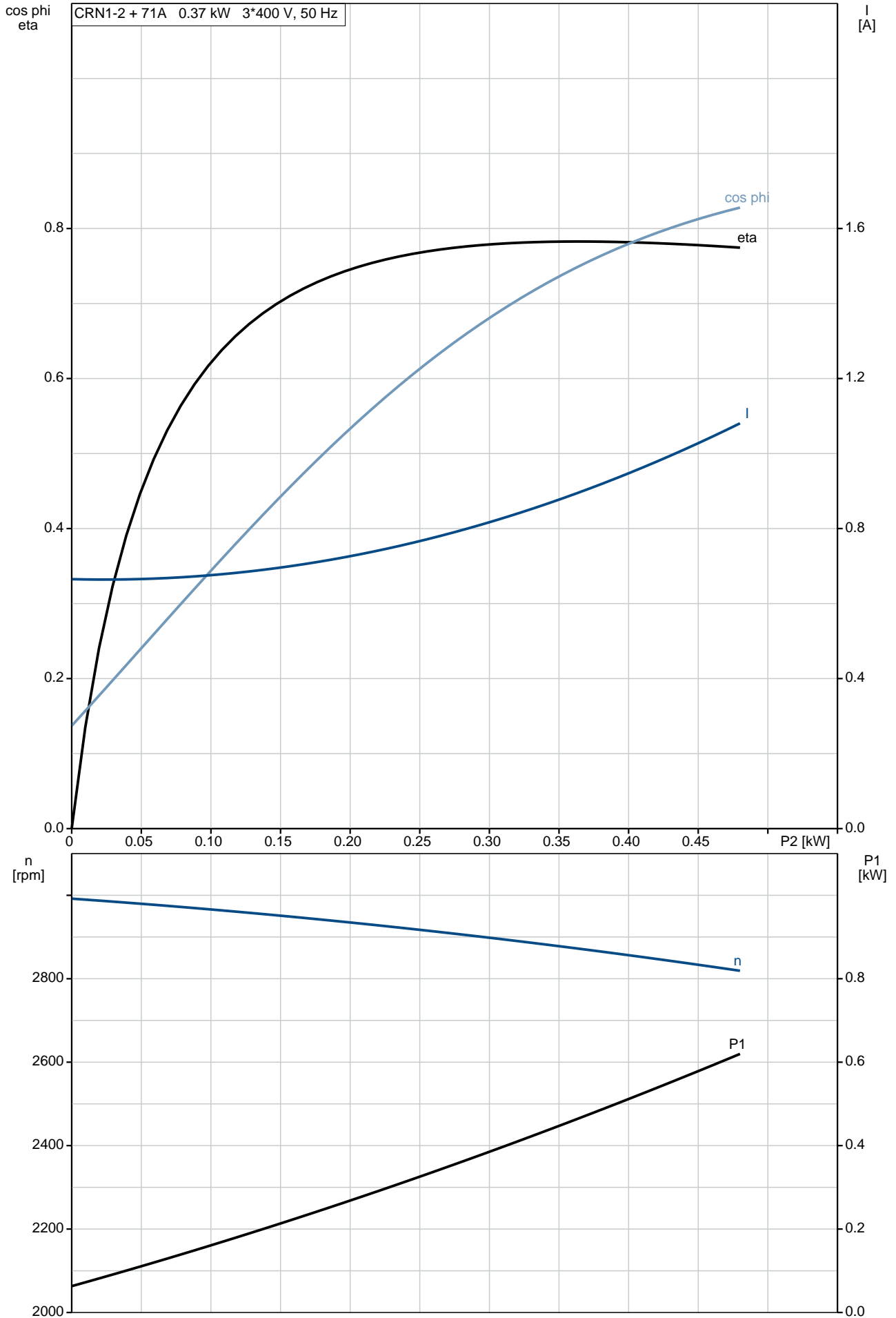

On request CRN 1-2 A-CA-A-V-HQQV 50 Hz

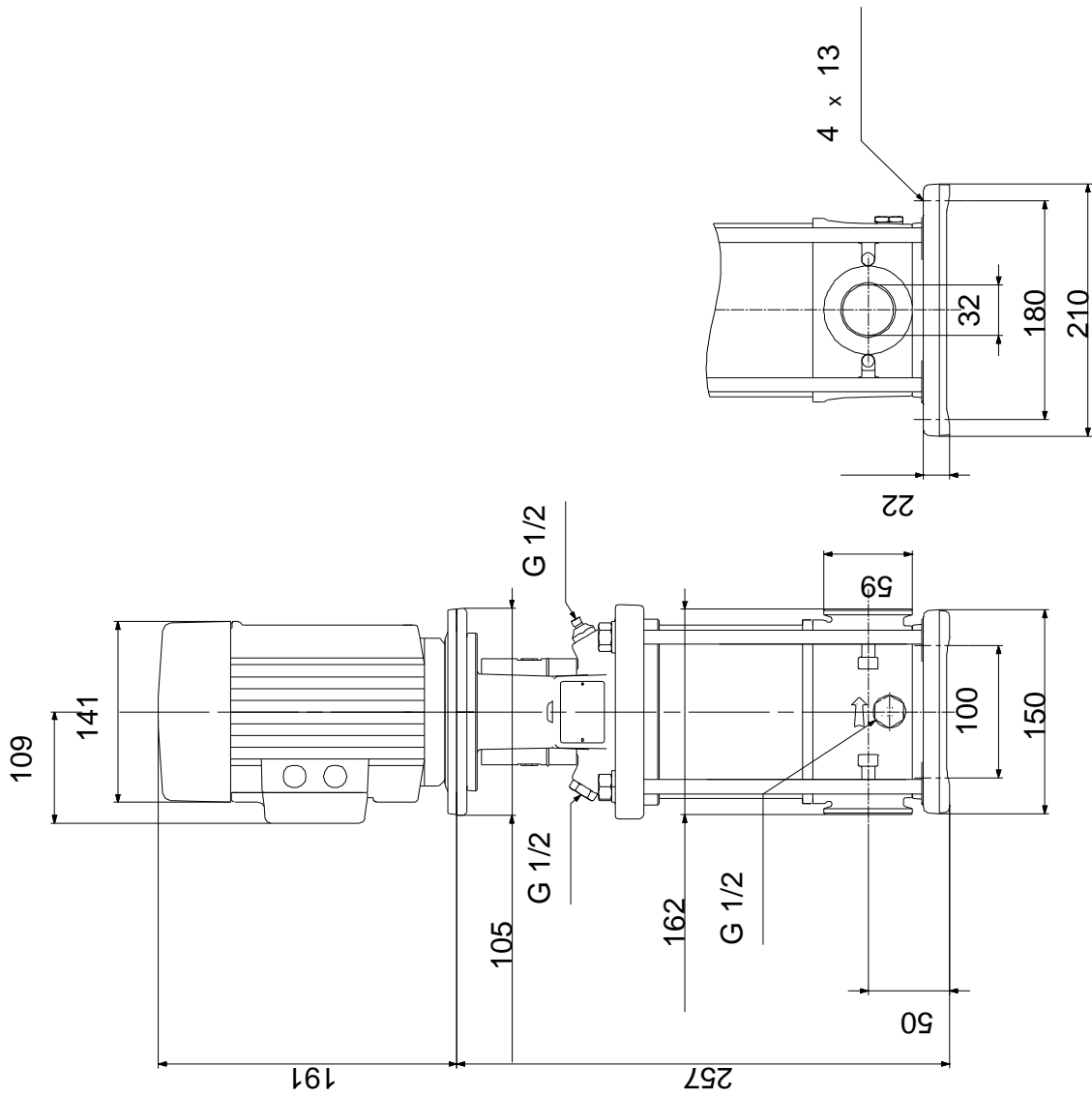

Note! All units are in [mm] unless others are stated.
 Disclaimer: This simplified dimensional drawing does not show all details.

Exploded view

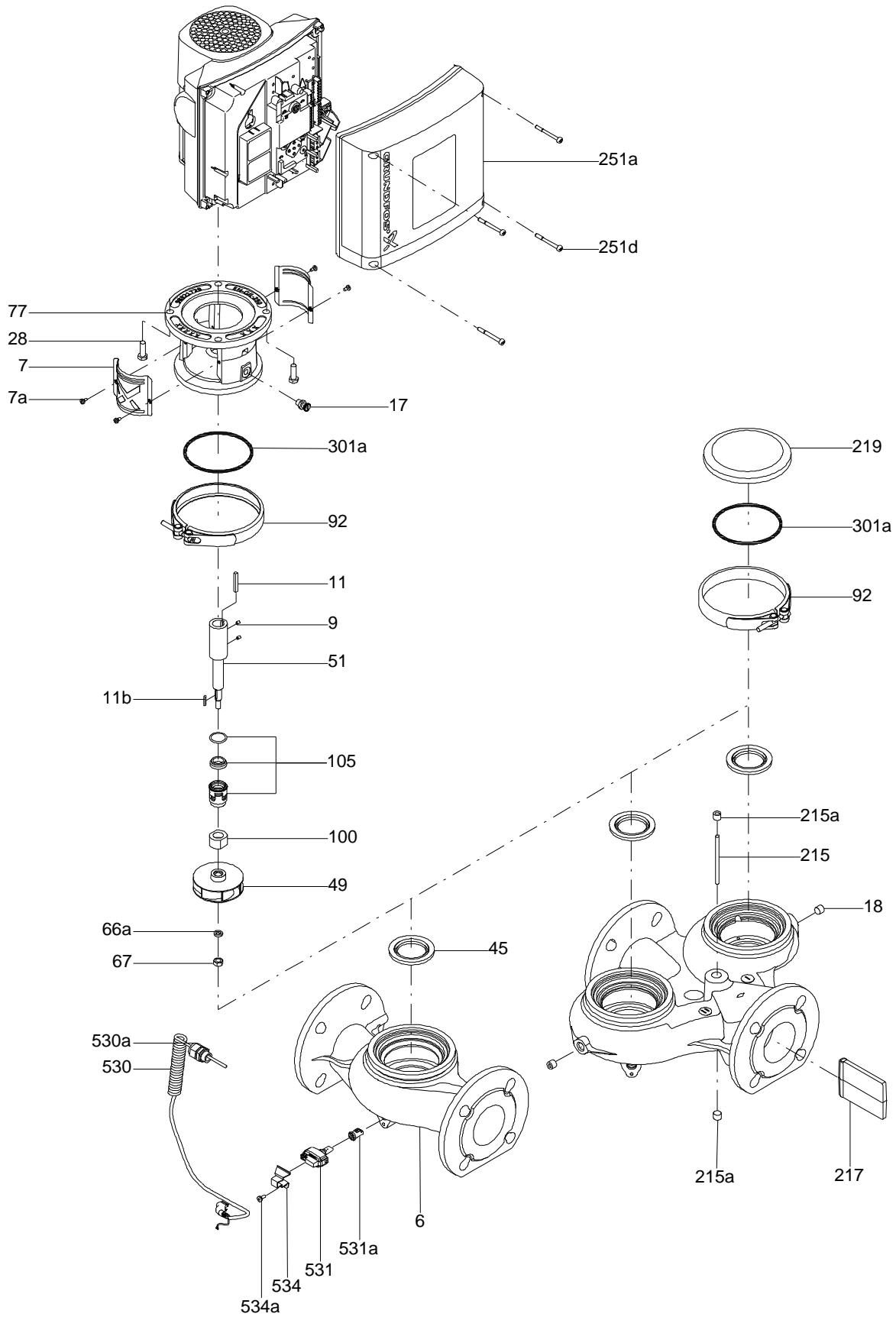

Sectional drawing (TM058200 for TPE2,TPE3)

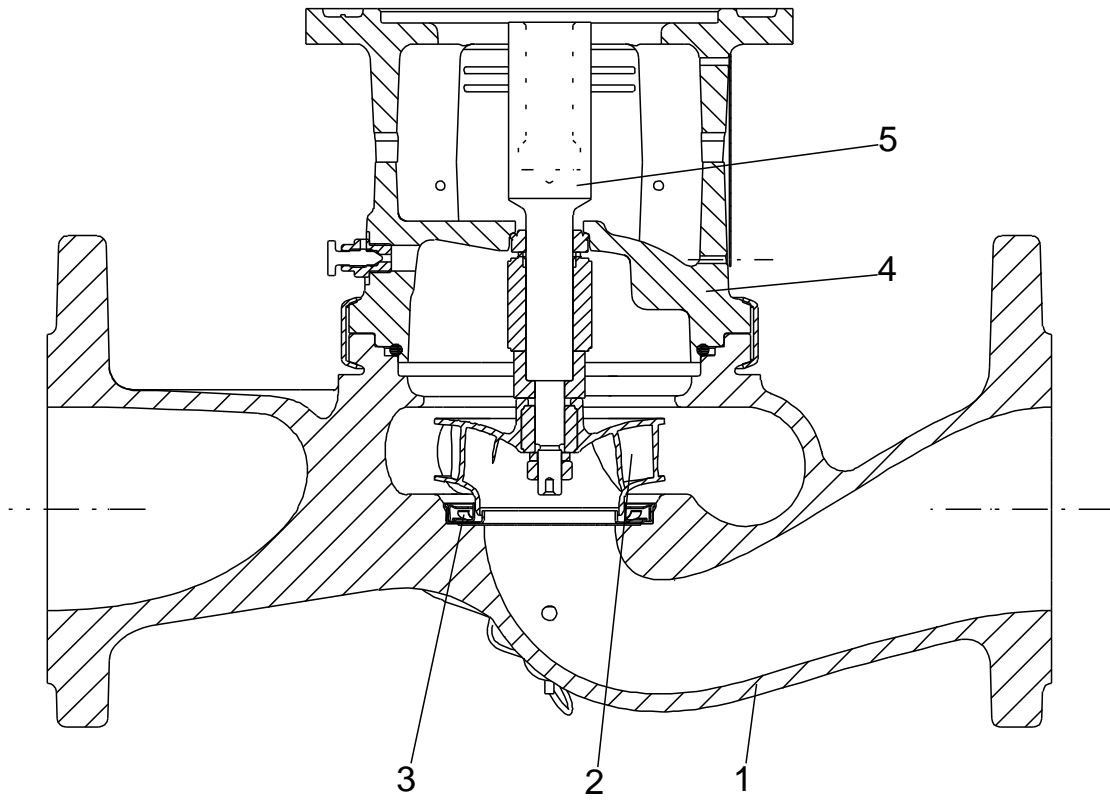

TM058200

Exploded view (TM057026 for MGE model H/I)

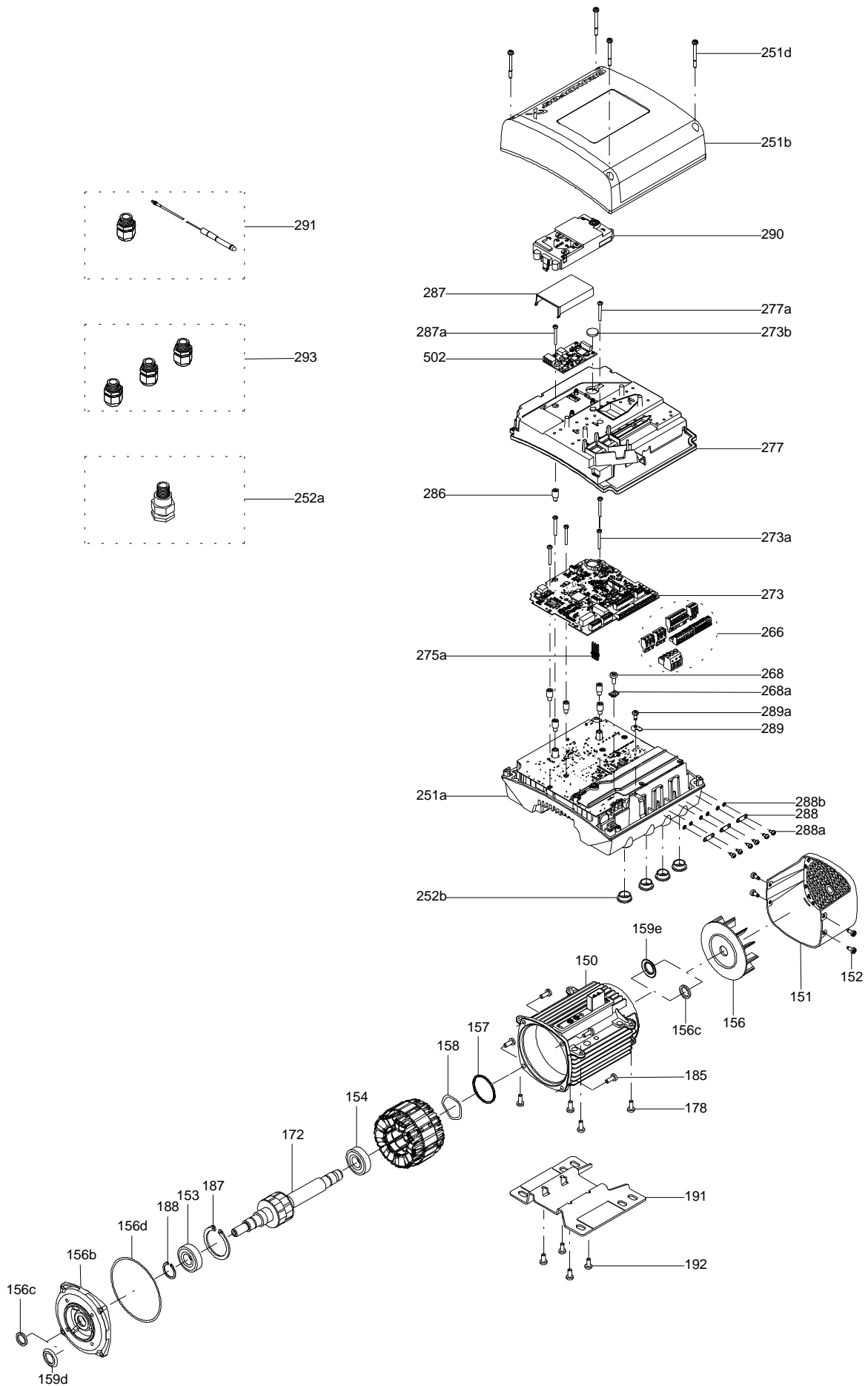

Parts list CRN 1-2, Product No. On request
Valid from 1.1.2004 (0401)

| Pos | Description | Annotation | Données de classification | Référence | Quantité | Unité |
|-------|---------------------------|------------|---------------------------|-----------|----------|-------|
| + | Motor | | | | 1 | pcs |
| - | Base cpl. | | | | 1 | pcs |
| 6 | Base | | | | 1 | |
| 56 | Base plate | | | | 1 | |
| - | Sealing parts | | | | 1 | pcs |
| - 25 | Drain plug w/bypass valve | | | | 1 | |
| 38 | O-ring | | Diameter: 16,3 | | 1 | |
| | | | Material type: FKM | | | |
| | | | Thickness: 2,4 | | | |
| 37 | O-ring | | Diameter: 137,5 | | 2 | |
| | | | Material type: FKM | | | |
| | | | Thickness: 3,3 | | | |
| 100 | O-ring | | Diameter: 16,3 | | 2 | |
| | | | Material type: FKM | | | |
| | | | Thickness: 2,4 | | | |
| - 2 | Pump head cpl. | | | | 1 | pcs |
| 2 | Pump head | | | | 1 | |
| 7 | Coupling guard | | | | 2 | |
| 7.a | Combi Slot Torx screw | | | | 4 | |
| - 18 | Air vent screw | | | | 1 | |
| | Plug | | | | 1 | |
| | Spindle | | | | 1 | |
| 23a | Plug | | | | 1 | |
| 28 | Hex head screw | | Length (mm): 20 | | 4 | |
| | | | Thread: M6 | | | |
| 60 | Formed wire spring | | | | 1 | |
| 77 | Pump cover | | | | 1 | |
| - 8 | Coupling | | | | 1 | pcs |
| 9 | Hex socket head cap screw | | Designation: DIN 912 | | 4 | |
| | | | Length (mm): 20 | | | |
| | | | Thread: M6 | | | |
| 10 | Shaft pin | | Diameter: 5 | | 1 | |
| | | | Length (mm): 26 | | | |
| 10a | Coupling half | | | | 2 | |
| 26 | Staybolt | | Length (mm): 155 | | 4 | pcs |
| | | | Thread: M12 | | | |
| 36 | Nut | | Thread: M12 | | 4 | pcs |
| 55 | Outer sleeve | | | | 1 | pcs |
| 66a | Washer | | Designation: DIN 125 A2 | | 4 | pcs |
| | | | Internal diameter: 13 | | | |
| | | | Outer diameter: 24 | | | |
| | | | Thickness: 2,5 | | | |
| - 80 | Chamber stack | | | | 1 | pcs |
| - 4 | Chamber cpl. | | | | 1 | |
| 4a | Intermediate chamber | | | | 1 | |
| 45 | Neck ring | | | | 1 | |
| 65 | Neck ring retainer | | | | 1 | |
| - 4a | Chamber w. bearing cpl. | | | | 1 | |
| 4a | Intermediate chamber | | | | 1 | |
| 45 | Neck ring | | | | 1 | |
| 65 | Neck ring retainer | | | | 1 | |
| - 5a | Chamber cpl. | | | | 1 | |
| 4a | Intermediate chamber | | | | 1 | |
| 45 | Neck ring | | | | 1 | |
| 65 | Neck ring retainer | | | | 1 | |
| 36 | Lock nut | | Thread: M8 | | 1 | |
| 47a | Bearing ring, rotating | | | | 1 | |
| 49 | Impeller cpl. | | | | 2 | |
| - 50a | Discharge part | | | | 1 | |

| Pos | Description | Annotation | Données de classification | Référence | Quantité | Unité |
|-------|-----------------------|------------|---------------------------|-----------|----------|-------|
| 50b | Top plate | | | | 1 | |
| 51 | Shaft, spline, cpl. | | | | 1 | |
| 64a | Spacing pipe | | Internal diameter: 12,85 | | 1 | |
| | | | Outer diameter: 15,85 | | | |
| | | | Length (mm): 4,50 | | | |
| 64c | Clamp, splined | | Internal diameter: 8,5 | | 1 | |
| | | | Outer diameter: 15 | | | |
| 66 | Wedge lock washer | | | | 1 | |
| 69 | Spacing bush | | | | 1 | |
| - 105 | Shaft seal | | Material type: HQQV | | 1 | pcs |
| | O-ring | | | | 1 | |
| | O-ring | | | | 1 | |
| | O-ring | | | | 1 | |
| | Seal driver, upper | | | | 1 | |
| | Seal driver, lower | | | | 1 | |
| | Spacer ring | | | | 1 | |
| | Pipe | | | | 1 | |
| | Plug | | | | 1 | |
| | Plug | | | | 1 | |
| | Compression spring | | | | 1 | |
| | Socket set screw | | | | 3 | |
| 103 | Seal ring, stationary | | | | 1 | |
| 105 | Seal ring, rotating | | | | 1 | |
| 109 | O-ring | | | | 1 | |
| 113 | Driver | | | | 1 | |

Disclaimer: The information about the Grundfos pump in this document may be outdated.

Data may be subject to alterations without further notice.

Please contact us to verify the data above is still accurate/up-to-date.

All information is copyright Grundfos.



info@lenntech.com

<https://www.lenntech.com>

tel. +31 152 610 900

fax. +31 152 616 289