

## CRN5-32 A-P-G-V-HQQV 3x400D 50HZ

Grundfos pump 96513508



Thank you for your interest in our products. Please contact us for more information, or visit our website

<https://www.lenntech.com/grundfos/CRN05/96513508/CRN-5-32-A-P-G-V-HQQV.html>

[info@lenntech.com](mailto:info@lenntech.com)

tel. +31 152 610 900

fax. +31 152 616 289

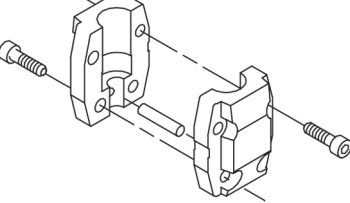
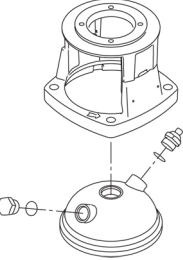
Position	Qty.	Description
	1	<p data-bbox="320 163 614 194"><b>CRN 5-32 A-P-A-V-HQQV</b></p>  <p data-bbox="320 488 598 519">Product No.: On request</p> <p data-bbox="320 548 1444 649">Vertical, multistage centrifugal pump with inlet and outlet ports on same the level (inline). Pump materials in contact with the liquid are in high-grade stainless steel. A cartridge shaft seal ensures high reliability, safe handling, and easy access and service. Power transmission is via a rigid split coupling. Pipe connection is via PJE (Victaulic®) couplings.</p> <p data-bbox="320 689 1053 721">The pump is fitted with a 3-phase, fan-cooled asynchronous motor.</p> <p data-bbox="320 750 638 781"><b>Further product details</b></p> <p data-bbox="320 788 1444 889">Steel, cast iron and aluminium components have an epoxy-based coating made in a cathodic electro-deposition (CED) process. CED is a high-quality dip-painting process where an electrical field around the products ensures deposition of paint particles as a thin, well-controlled layer on the surface. An integral part of the process is a pretreatment. The entire process consists of these elements:</p> <ol data-bbox="320 896 1029 1041" style="list-style-type: none"> <li>1) Alkaline-based cleaning.</li> <li>2) Zinc phosphating.</li> <li>3) Cathodic electro-deposition.</li> <li>4) Curing to a dry film thickness 18-22 my m.</li> </ol> <p data-bbox="320 1019 1029 1050">The colour code for the finished product is NCS 9000/RAL 9005.</p> <p data-bbox="320 1079 406 1111"><b>Pump</b></p> <p data-bbox="320 1117 1412 1167">A standard split coupling connects the pump and motor shaft. It is enclosed in the pump head/motor stool by means of two coupling guards.</p>  <p data-bbox="320 1411 1444 1489">The pump head and flange for motor mounting is made in one piece (cast iron). The pump head cover is a separate component (stainless steel). The pump head has a combined 1/2" priming plug and vent screw.</p>  <p data-bbox="320 1792 1420 1892">The pump is fitted with a balanced O-ring seal unit with a rigid torque-transmission system. This seal type is assembled in a cartridge unit which makes replacement safe and easy. Due to the balancing, this seal type is suitable for high-pressure applications. The cartridge construction also protects the pump shaft from possible wear from a dynamic O-ring between pump shaft and shaft seal.</p> <p data-bbox="320 1904 470 1935">Primary seal:</p> <ul data-bbox="359 1937 917 1989" style="list-style-type: none"> <li>• Rotating seal ring material: silicon carbide (SiC)</li> <li>• Stationary seat material: silicon carbide (SiC)</li> </ul> <p data-bbox="320 1993 1428 2042">This material pairing is used where higher corrosion resistance is required. The high hardness of this material pairing offers good resistance against abrasive particles.</p> <p data-bbox="320 2049 893 2080">Secondary seal material: FKM (fluorocarbon rubber)</p>

FKM has excellent resistance to oils and chemicals. Above 90 °C, FKM should only be used in media without water.

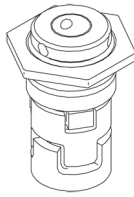

The shaft seal is screwed into the pump head.

The chambers and impellers are made of stainless-steel sheet. The chambers are provided with a PTFE neck ring offering improved sealing and high efficiency. The impellers have smooth surfaces, and the shape of the blades ensure a high efficiency.

The pump has a stainless-steel base mounted on a separate base plate. The base and base plate are kept in position by the tension of the staybolts which hold the pump together. The outlet side of the base has a combined drain plug and bypass valve. The pump is secured to the foundation by four bolts through the base plate. The base is prepared for connection by means of PJE (Victualic®) couplings.

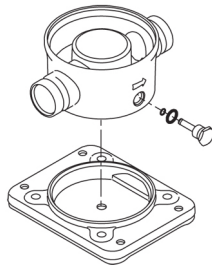

### Motor

The motor is a totally enclosed, fan-cooled motor with principal dimensions to IEC and DIN standards. The motor is flange-mounted with free-hole flange (FF).

Motor-mounting designation in accordance with IEC 60034-7: IM B 5 (Code I) / IM 3001 (Code II).

Electrical tolerances comply with IEC 60034.

The motor efficiency is classified as IE3 in accordance with IEC 60034-30-1.

The motor has thermistors (PTC sensors) in the windings in accordance with DIN 44081/DIN 44082. The protection reacts to both slow- and quick-rising temperatures, e.g. constant overload and stalled conditions.

Thermal switches must be connected to an external control circuit in a way which ensures that the automatic reset cannot cause accidents. The motors must be connected to a motor-protective circuit breaker according to local regulations.

The motor can be connected to a variable speed drive for adjustment of pump performance to any duty point. Grundfos CUE offers a range of variable speed drives. Please find more information in Grundfos Product Center.

### Technical data

#### Controls:

Frequency converter: NONE

#### Liquid:

Pumped liquid: Water  
Liquid temperature range: -20 .. 90 °C  
Liquid temperature during operation: 20 °C  
Density: 998.2 kg/m<sup>3</sup>

#### Technical:

Rated flow: 5.8 m<sup>3</sup>/h  
Rated head: 168.6 m  
Pump orientation: Vertical  
Shaft seal arrangement: Single

Position	Qty.	Description
		Code for shaft seal:                   HQQV Approvals on nameplate:           CE, EAC Curve tolerance:                       ISO9906:2012 3B  <b>Materials:</b> Base:                                       Stainless steel EN 1.4408 AISI 316 Impeller:                               Stainless steel EN 1.4401 AISI 316 Bearing:                                 SIC  <b>Installation:</b> Maximum ambient temperature: 60 °C Maximum operating pressure: 25 bar Max pressure at stated temp: 25 bar / 90 °C 25 bar / -20 °C Type of connection:                 PJE Size of inlet connection:           DN 32 1 1/4 inch Size of outlet connection:         DN 32 1 1/4 inch Pressure rating for pipe connection: PN 50 Flange size for motor:             FF265  <b>Electrical data:</b> Motor standard:                       IEC Motor type:                             132SC IE Efficiency class:                 IE3 Rated power - P2:                   5.5 kW Power (P2) required by pump: 5.5 kW Mains frequency:                   50 Hz Rated voltage:                       3 x 380-415D V Rated current:                       11 A Starting current:                   1080-1180 % Cos phi - power factor:           0.87-0.82 Rated speed:                         2920-2940 rpm Efficiency:                            IE3 89,2% Motor efficiency at full load:     89.2 % Motor efficiency at 3/4 load:     90.0 % Motor efficiency at 1/2 load:     89.6 % Number of poles:                    2 Enclosure class (IEC 34-5):     55 Dust/Jetting Insulation class (IEC 85):        F  <b>Others:</b> Minimum efficiency index, MEI : 0.57 Net weight:                          75.6 kg Gross weight:                       99 kg Shipping volume:                    0.365 m³

# On request CRN 5-32 A-P-A-V-HQQV 50 Hz

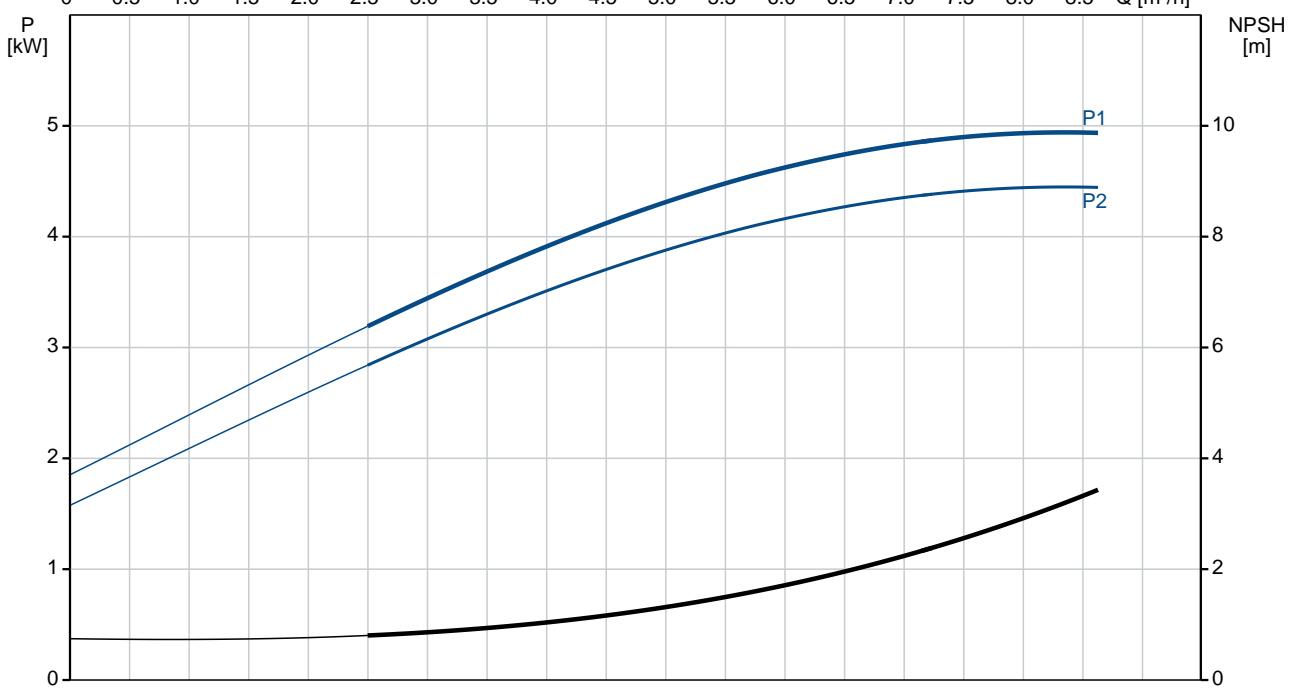
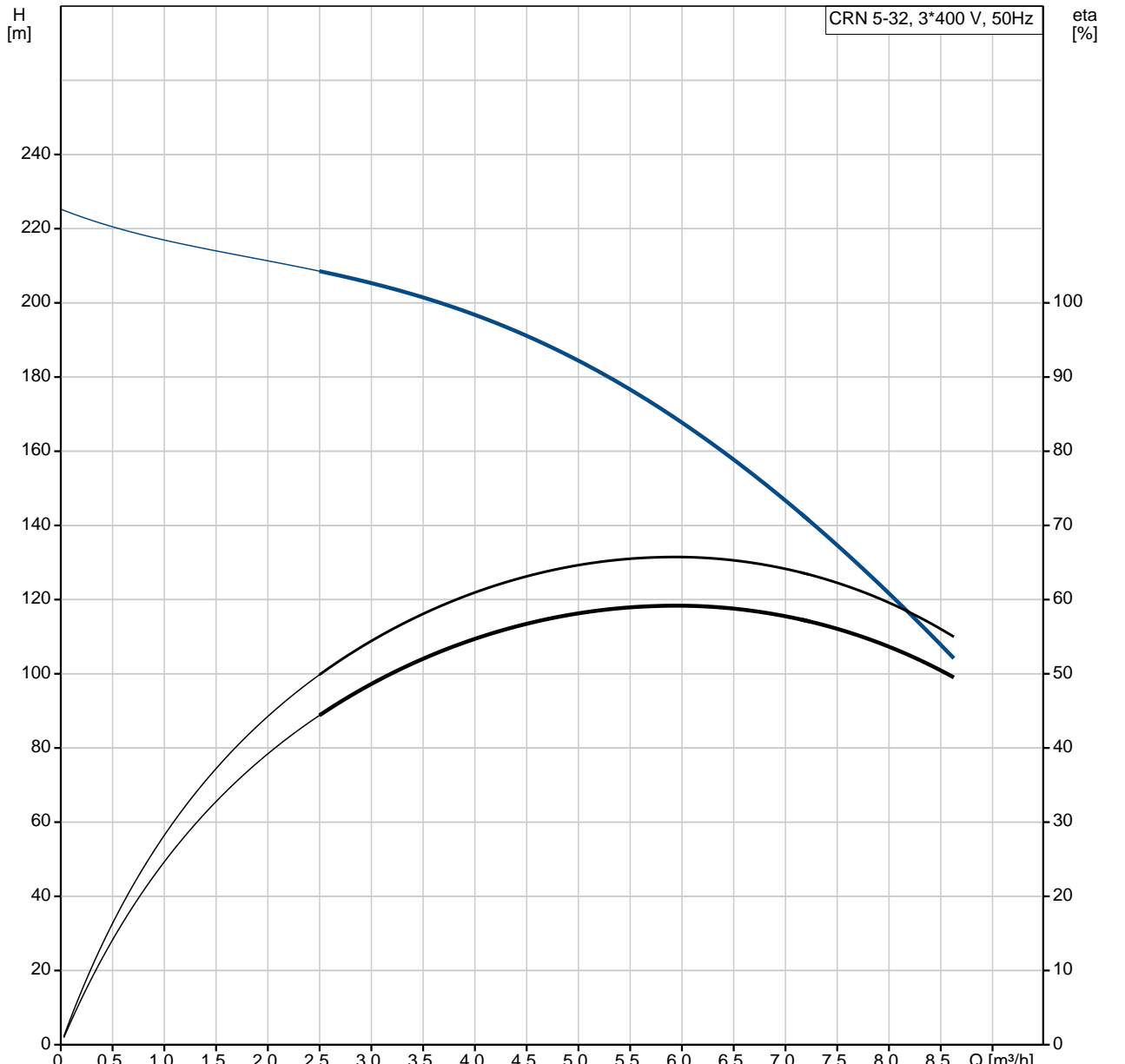

Description	Value
<b>General information:</b>	
Product name:	CRN 5-32 A-P-A-V-HQQV
Product No:	On request
EAN number:	On request
<b>Technical:</b>	
Rated flow:	5.8 m <sup>3</sup> /h
Rated head:	168.6 m
Stages:	32
Impellers:	32
Number of reduced-diameter impellers:	0
Low NPSH:	N
Pump orientation:	Vertical
Shaft seal arrangement:	Single
Code for shaft seal:	HQQV
Approvals on nameplate:	CE, EAC
Curve tolerance:	ISO9906:2012 3B
Pump version:	A
Model:	A
<b>Materials:</b>	
Base:	Stainless steel EN 1.4408 AISI 316
Impeller:	Stainless steel EN 1.4401 AISI 316
Material code:	A
Code for rubber:	V
Bearing:	SIC
<b>Installation:</b>	
Maximum ambient temperature:	60 °C
Maximum operating pressure:	25 bar
Max pressure at stated temp:	25 bar / 90 °C 25 bar / -20 °C
Type of connection:	PJE
Size of inlet connection:	DN 32 1 1/4 inch
Size of outlet connection:	DN 32 1 1/4 inch
Pressure rating for pipe connection:	PN 50
Flange size for motor:	FF265
Connect code:	P
<b>Liquid:</b>	
Pumped liquid:	Water
Liquid temperature range:	-20 .. 90 °C
Liquid temperature during operation:	20 °C
Density:	998.2 kg/m <sup>3</sup>
<b>Electrical data:</b>	
Motor standard:	IEC
Motor type:	132SC
IE Efficiency class:	IE3
Rated power - P2:	5.5 kW
Power (P2) required by pump:	5.5 kW
Mains frequency:	50 Hz
Rated voltage:	3 x 380-415D V
Rated current:	11 A
Starting current:	1080-1180 %
Cos phi - power factor:	0.87-0.82
Rated speed:	2920-2940 rpm
Efficiency:	IE3 89.2%
Motor efficiency at full load:	89.2 %
Motor efficiency at 3/4 load:	90.0 %
Motor efficiency at 1/2 load:	89.6 %
Number of poles:	2

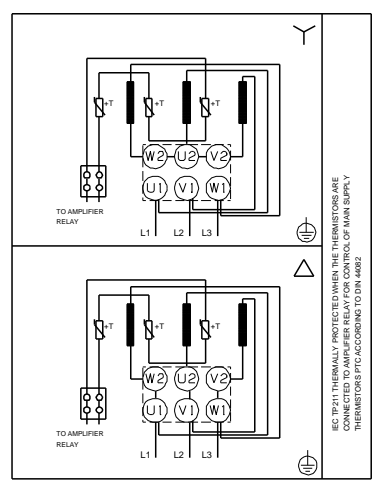
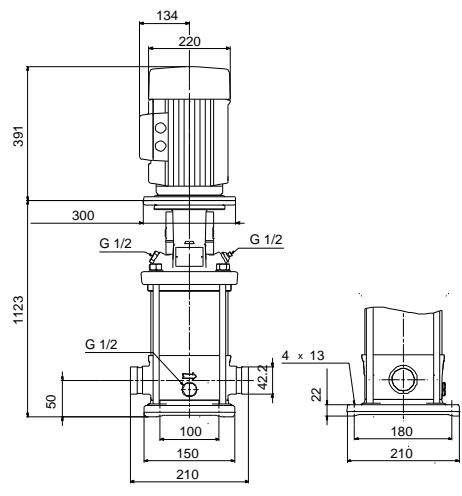
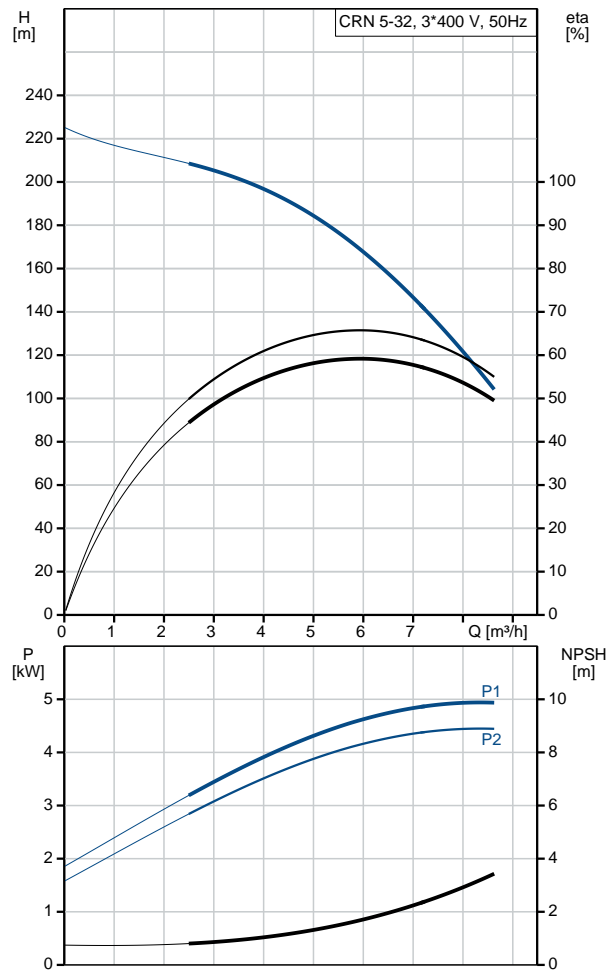

Description	Value
Enclosure class (IEC 34-5):	55 Dust/Jetting
Insulation class (IEC 85):	F
Motor protec:	PTC
Motor No:	85U17417
<b>Controls:</b>	
Frequency converter:	NONE
<b>Others:</b>	
Minimum efficiency index, MEI :	0.57
Net weight:	75.6 kg
Gross weight:	99 kg
Shipping volume:	0.365 m <sup>3</sup>

# On request CRN 5-32 A-P-A-V-HQQV 50 Hz

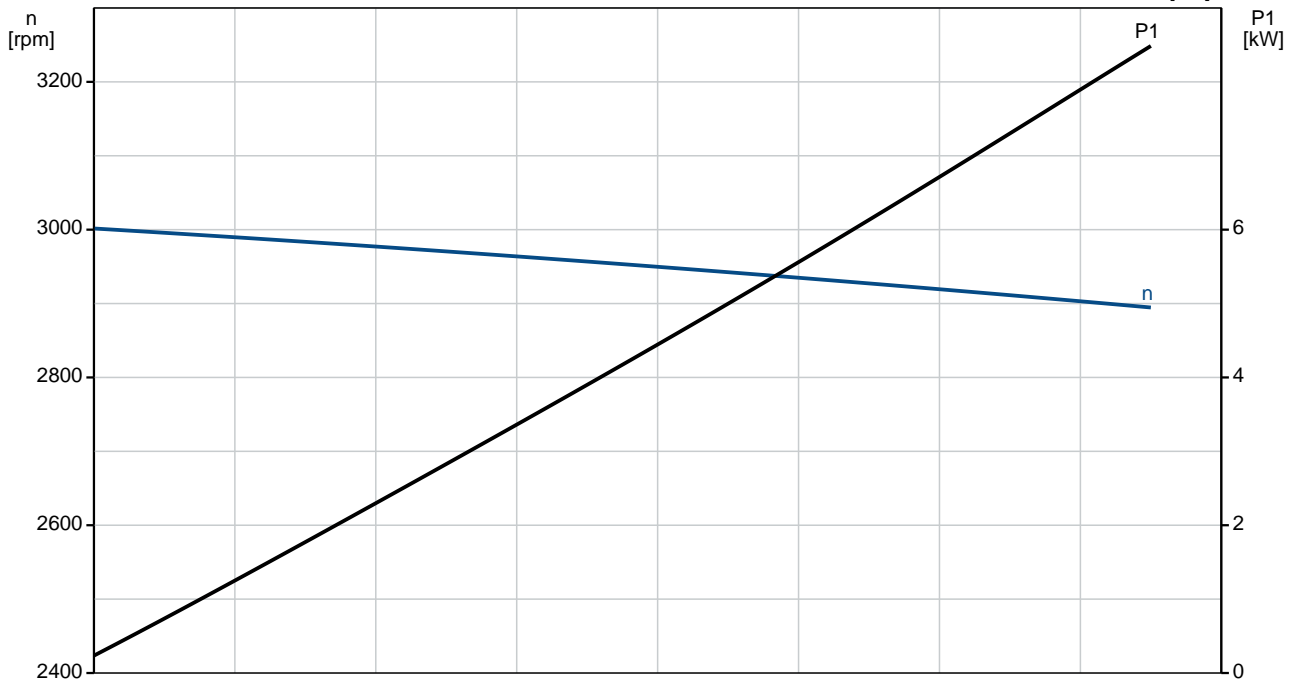
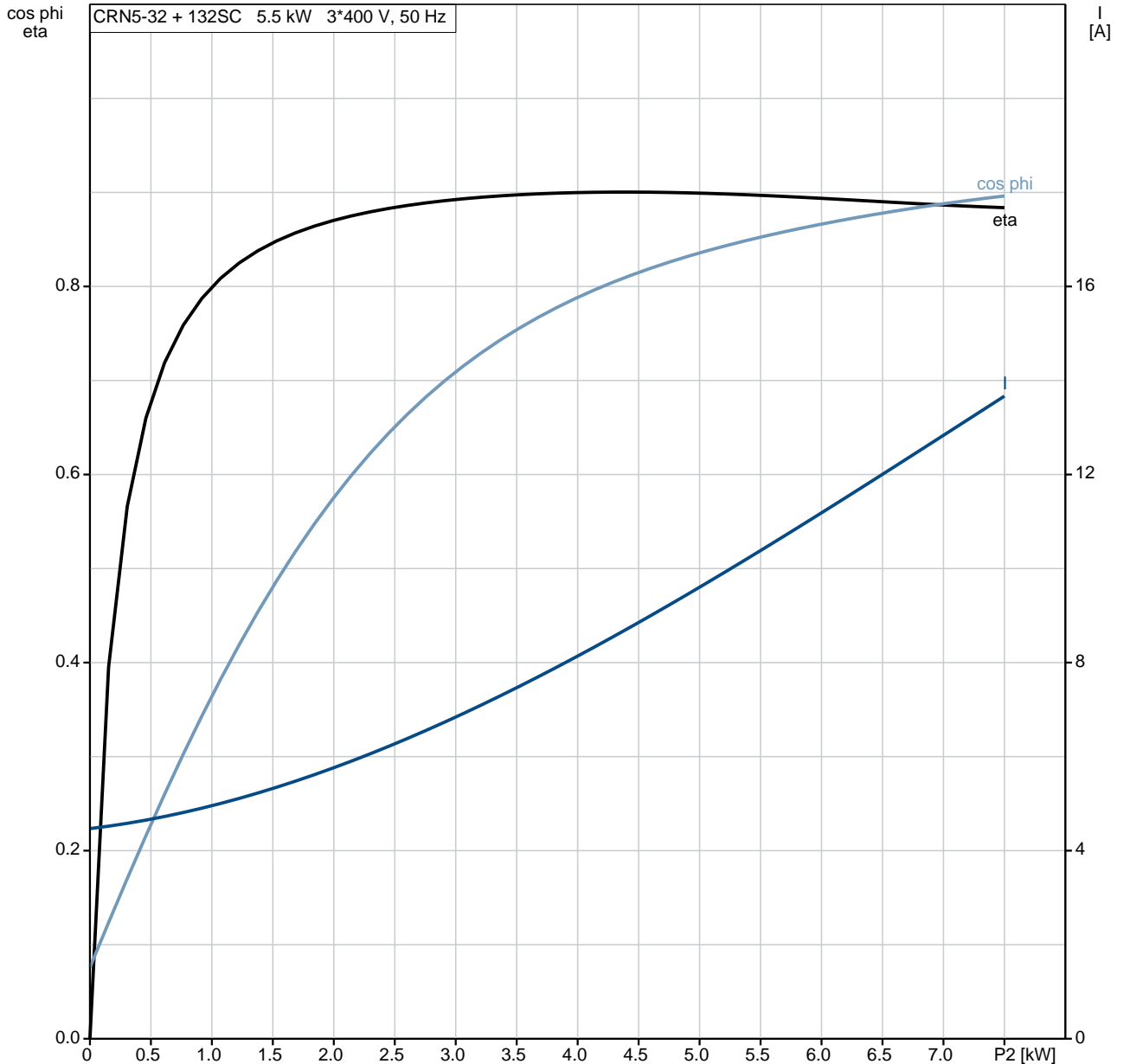



**On request CRN 5-32 A-P-A-V-HQQV 50 Hz**

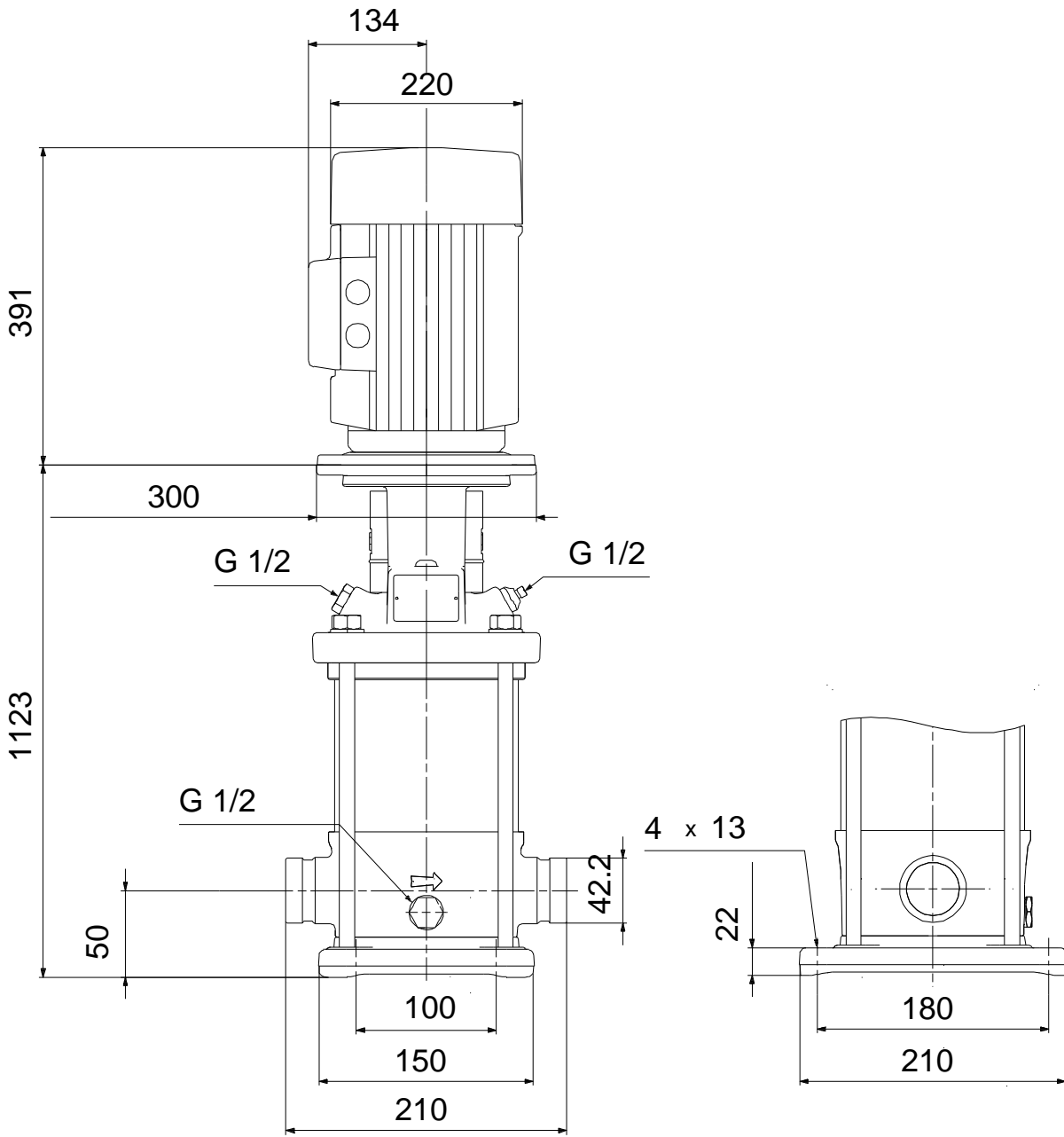

Note! All units are in [mm] unless others are stated.  
Disclaimer: This simplified dimensional drawing does not show all details.

Exploded view

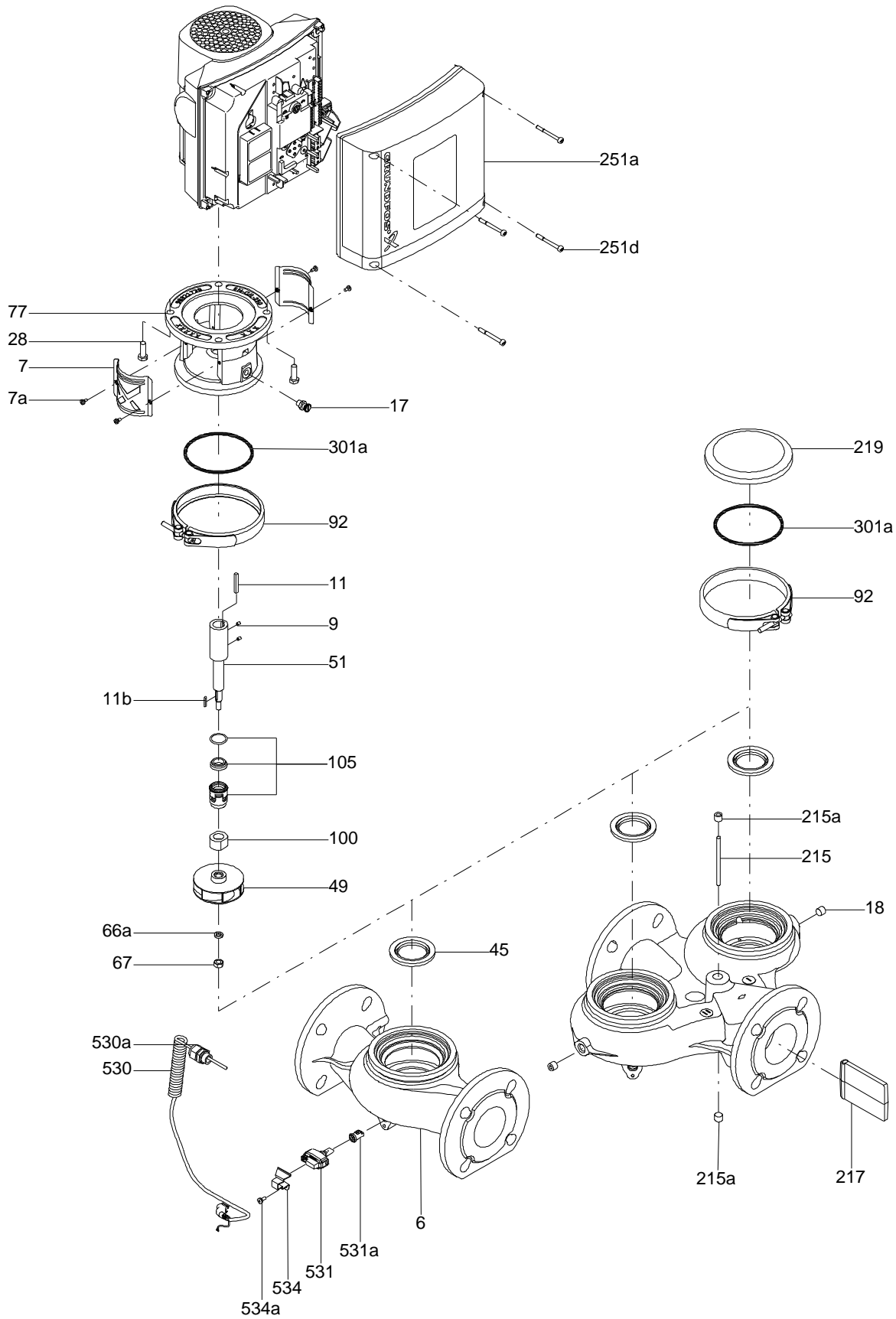

Sectional drawing (TM058200 for TPE2,TPE3)



TM058200

**Exploded view ( TM057026 for MGE model H/I )**



**Parts list CRN 5-32, Product No. On request**  
**Valid from 1.1.2011 (1152)**

Pos	Description	Annotation	Données de classification	Référence	Quantité	Unité
+	Motor				1	pcs
-	Base cpl.				1	pcs
6	Base				1	
25	Plug				2	
56	Base plate				1	
-	Sealing parts				1	pcs
- 25	Drain plug w/bypass valve				1	
38	O-ring		Diameter: 16,3		1	
			Material type: FKM			
			Thickness: 2,4			
37	O-ring		Diameter: 137,5		2	
			Material type: FKM			
			Thickness: 3,3			
100	O-ring		Diameter: 16,3		2	
			Material type: FKM			
			Thickness: 2,4			
- 2	Pump head cpl.				1	pcs
2	Pump head				1	
7	Coupling guard				2	
7.a	Combi Slot Torx screw				4	
- 18	Air vent screw				1	
	Plug				1	
	Spindle				1	
23a	Plug				1	
28a	Hex head screw		Length (mm): 45 MM		4	
			Thread: M12			
60	Formed wire spring				1	
66a	Nut		Thread: M12		4	
77	Pump cover				1	
- 8	Coupling cpl.				1	pcs
9	Hex socket head cap screw		Designation: DIN 912		4	
			Length (mm): 25			
			Thread: M10			
10	Shaft pin		Diameter: 5		1	
			Length (mm): 26			
10a	Coupling				1	
26	Staybolt		Length (mm): 959		4	pcs
			Thread: M12			
36	Nut		Thread: M12		4	pcs
55	Outer sleeve				1	pcs
66a	Washer		Designation: DIN 125 A2		4	pcs
			Internal diameter: 13			
			Outer diameter: 24			
			Thickness: 2,5			
- 80	Chamber stack				1	pcs
- 4	Chamber cpl.				25	
	Chamber				1	
45	Neck ring				1	
65	Neck ring retainer				1	
- 4a	Chamber w. bearing cpl.				6	
	Chamber				1	
45	Neck ring				1	
65	Neck ring retainer				1	
- 5a	Chamber cpl.				1	
	Chamber				1	
45	Neck ring				1	
65	Neck ring retainer				1	
36	Lock nut		Thread: M8		1	
47a	Bearing ring, rotating				6	

Pos	Description	Annotation	Données de classification	Référence	Quantité	Unité
+ 49	Impeller cpl.				32	
- 50a	Guide vane				1	
	Guide vane				6	
	Plate				1	
50b	Top plate				1	
- 51	Shaft, spline, cpl.				1	
51	Shaft				1	
62	Stop ring				1	
64a	Spacing pipe		Length (mm): 13.00		6	
64c	Clamp, splined		Internal diameter: 8,5 Outer diameter: 15		1	
66	Wedge lock washer				1	
69	Spacing pipe		Length (mm): 26.0		25	
69	Spacing pipe		Length (mm): 2.00		1	
- 105	Shaft seal		Material type: HQQV		1	pcs
	O-ring				1	
	O-ring				1	
	O-ring				1	
	Seal driver, upper				1	
	Seal driver, lower				1	
	Spacer ring				1	
	Pipe				1	
	Plug				1	
	Plug				1	
	Compression spring				1	
	Socket set screw				3	
103	Seal ring, stationary				1	
105	Seal ring, rotating				1	
109	O-ring				1	
113	Driver				1	

*Disclaimer: The information about the Grundfos pump in this document may be outdated.*

*Data may be subject to alterations without further notice.*

*Please contact us to verify the data above is still accurate/up-to-date.*

All information is copyright Grundfos.



[info@lenntech.com](mailto:info@lenntech.com)

<https://www.lenntech.com>

tel. +31 152 610 900

fax. +31 152 616 289