

TP 65-60/2-A-F-A-BUBE 1X230 50HZ Grundfos pump 96402266



Thank you for your interest in our products. Please contact us for more information, or visit our website

<https://www.lenntech.com/grundfos/TP000/96402266/TP-65-60-2-A-F-A-BUBE.html>

info@lenntech.com

tel. +31 152 610 900

fax. +31 152 616 289

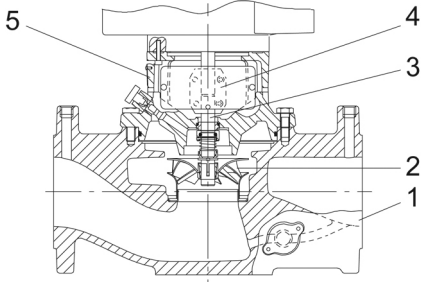
Position	Qty.	Description
	1	<p data-bbox="320 163 598 197">TP 65-60/2 A-F-A-BUBE</p>  <p data-bbox="320 488 598 521">Product No.: On request</p> <p data-bbox="320 544 1444 622">Single-stage, close-coupled, volute pump with in-line suction and discharge ports of identical diameter. The pump is of the top-pull-out design, i.e. the power head (motor, pump head and impeller) can be removed for maintenance or service while the pump housing remains in the pipework.</p> <p data-bbox="320 633 1420 689">The pump is fitted with an unbalanced rubber bellows seal. The shaft seal is according to EN 12756. Pipework connection is via PN 6/10 DIN flanges (EN 1092-2 and ISO 7005-2).</p> <p data-bbox="320 701 949 734">The pump is fitted with a fan-cooled asynchronous motor.</p> <p data-bbox="320 745 638 779">Further product details</p> <p data-bbox="320 790 1428 869">The product's minimum efficiency index (MEI) is greater or equal to 0.70. This is by the Commission Regulation (EU) considered as an indicative benchmark for best-performing water pump available on the market as from 1 January 2013.</p> <p data-bbox="320 902 406 936">Pump</p> <p data-bbox="320 947 1252 981">Pump housing and pump head are electrocoated to improve the corrosion resistance.</p> <p data-bbox="320 992 582 1025">Electrocoating includes:</p> <ol data-bbox="320 1037 805 1115" style="list-style-type: none"> 1) Alkaline-based cleaning. 2) Pretreatment with zinc phosphate coating. 3) Cathodic electrocoating (epoxy). 4) Curing of paint film at 200-250 °C.  <ol data-bbox="320 1440 502 1597" style="list-style-type: none"> 1: Pump housing 2: Impeller 3: Shaft 4: Coupling 5: Pump head <p data-bbox="320 1619 1460 1697">The pump housing is provided with a replaceable stainless steel/PTFE neck ring to reduce the amount of liquid running from the discharge side of the impeller to the suction side. The impeller is secured with a split cone with nut.</p> <p data-bbox="320 1731 1444 1809">The pump is fitted with an unbalanced rubber bellows seal with torque transmission across the spring and around the bellows. Due to the bellows, the seal does not wear the shaft, and the axial movement is not prevented by deposits on the shaft.</p> <p data-bbox="320 1821 470 1854">Primary seal:</p> <ul data-bbox="359 1865 1061 1910" style="list-style-type: none"> • Rotating seal ring material: tungsten carbide (WC) • Stationary seat material: carbon graphite, resin-impregnated <p data-bbox="320 1921 1428 2011">This is a widely used material pairing. If the pumped liquid contains particles, wear on the seal faces must be expected. Due to the favourable lubricating properties of carbon graphite, the seal is suitable for use even under poor lubricating conditions, such as hot water. However, under such conditions, wear on the carbon graphite face reduces seal life.</p> <p data-bbox="320 2022 981 2056">Secondary seal material: EPDM (ethylene-propylene rubber)</p> <p data-bbox="320 2067 1220 2101">EPDM has excellent resistance to hot water. EPDM is not suitable for mineral oils.</p>

Position	Qty.	Description
		<p>A circulation of liquid through the duct of the air vent screw ensures lubrication and cooling of the shaft seal.</p> <p>The flanges have tappings for mounting of pressure gauges.</p> <p>The motor stool forms connection between the pump housing and the motor, and is equipped with a manual air vent screw for venting of the pump housing and the shaft seal chamber. The sealing between motor stool and pump housing is an O-ring.</p> <p>The central part of the motor stool is provided with guards for protection against the shaft and coupling. Motor and pump shaft are connected via a shell coupling.</p> <p>Motor</p> <p>The motor is a totally enclosed, fan-cooled motor with principal dimensions to IEC and DIN standards. Electrical tolerances comply with IEC 60034.</p> <p>The motor is flange-mounted with tapped-hole flange (FT). Motor-mounting designation in accordance with IEC 60034-7: IM B 14, IM V 18 (Code I) / IM 3601, IM 3611 (Code II).</p> <p>The motor has built-in thermal protection (PTO current and temperature sensors) in accordance with IEC 60034-11 and requires no further motor protection. The protection reacts to both slow- and quick-rising temperatures, e.g. constant overload and stalled conditions.</p> <p>As the thermal protection incorporates automatic reset, the motor must be connected in a way which ensures that the automatic reset cannot cause accidents.</p> <p>Technical data</p> <p>Liquid: Pumped liquid: Water Liquid temperature range: 0 .. 140 °C Liquid temperature during operation: 20 °C Density: 998.2 kg/m³</p> <p>Technical: Rated flow: 26.7 m³/h Rated head: 3.85 m Actual impeller diameter: 76 mm Primary shaft seal: BUBE Curve tolerance: ISO9906:2012 3B</p> <p>Materials: Pump housing: Cast iron EN-JL1040 ASTM A48-40 B Impeller: Stainless steel DIN W.-Nr. 1.4301 AISI 304</p> <p>Installation: Range of ambient temperature: -30 .. 40 °C Maximum operating pressure: 10 bar Flange standard: DIN Pipe connection: DN 65 Pump inlet: DN 65 Pump outlet: DN 65 Pressure rating: PN 6/10 (@): 340 mm Flange size for motor: FT100</p> <p>Electrical data: Motor type: 80A Rated power - P2: 0.55 kW Power (P2) required by pump: 0.55 kW Mains frequency: 50 Hz Rated voltage: 1 x 220-230/240 V Rated current: 4.00/3.65 A</p>

Position	Qty.	Description
		<p>Starting current: 280 %</p> <p>Cos phi - power factor: 0.99</p> <p>Rated speed: 2750 rpm</p> <p>Motor efficiency at full load: 66-64 %</p> <p>Number of poles: 2</p> <p>Enclosure class (IEC 34-5): 55 Dust/Jetting</p> <p>Insulation class (IEC 85): F</p> <p>Others:</p> <p>Minimum efficiency index, MEI : 0.70</p> <p>ErP status: EuP Standalone/Prod.</p> <p>Net weight: 28.6 kg</p> <p>Gross weight: 31.4 kg</p> <p>Shipping volume: 0.07 m³</p>

On request TP 65-60/2 A-F-A-BUBE 50 Hz

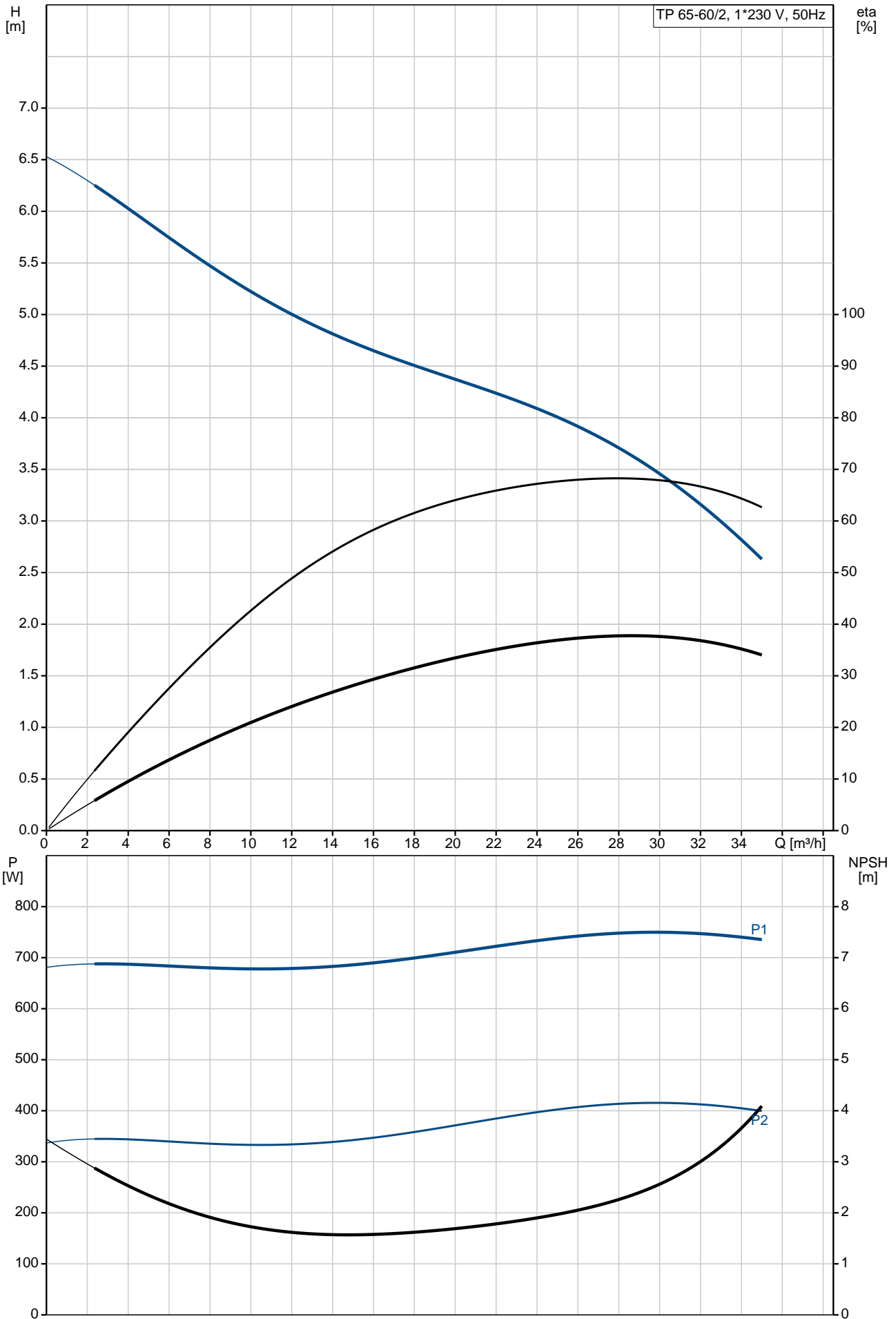

Description	Value
General information:	
Product name:	TP 65-60/2 A-F-A-BUBE
Product No:	On request
EAN number:	On request
Technical:	
Rated flow:	26.7 m ³ /h
Rated head:	3.85 m
Head max:	60 dm
Actual impeller diameter:	76 mm
Primary shaft seal:	BUBE
Curve tolerance:	ISO9906:2012 3B
Pump version:	A
Model:	A
Materials:	
Pump housing:	Cast iron EN-JL1040 ASTM A48-40 B
Impeller:	Stainless steel DIN W.-Nr. 1.4301 AISI 304
Material code:	A
Installation:	
Range of ambient temperature:	-30 .. 40 °C
Maximum operating pressure:	10 bar
Flange standard:	DIN
Pipe connection:	DN 65
Pump inlet:	DN 65
Pump outlet:	DN 65
Pressure rating:	PN 6/10
(@)	340 mm
Flange size for motor:	FT100
Connect code:	F
Liquid:	
Pumped liquid:	Water
Liquid temperature range:	0 .. 140 °C
Liquid temperature during operation:	20 °C
Density:	998.2 kg/m ³
Electrical data:	
Motor type:	80A
Rated power - P2:	0.55 kW
Power (P2) required by pump:	0.55 kW
Mains frequency:	50 Hz
Rated voltage:	1 x 220-230/240 V
Rated current:	4.00/3.65 A
Starting current:	280 %
Cos phi - power factor:	0.99
Rated speed:	2750 rpm
Motor efficiency at full load:	66-64 %
Number of poles:	2
Enclosure class (IEC 34-5):	55 Dust/Jetting
Insulation class (IEC 85):	F
Motor protec:	PTO
Motor No:	85215103
Others:	
Minimum efficiency index, MEI :	0.70
ErP status:	EuP Standalone/Prod.
Net weight:	28.6 kg
Gross weight:	31.4 kg
Shipping volume:	0.07 m ³

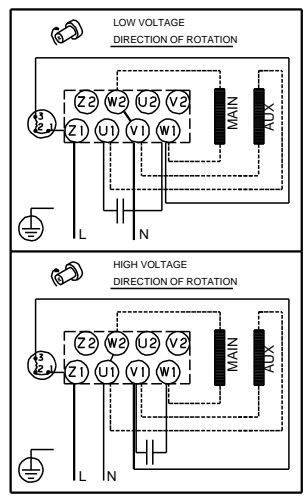
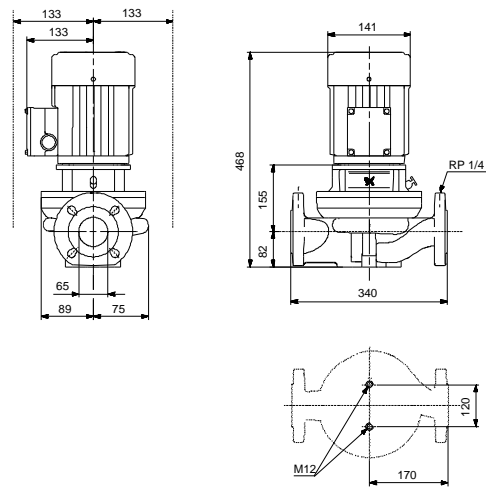
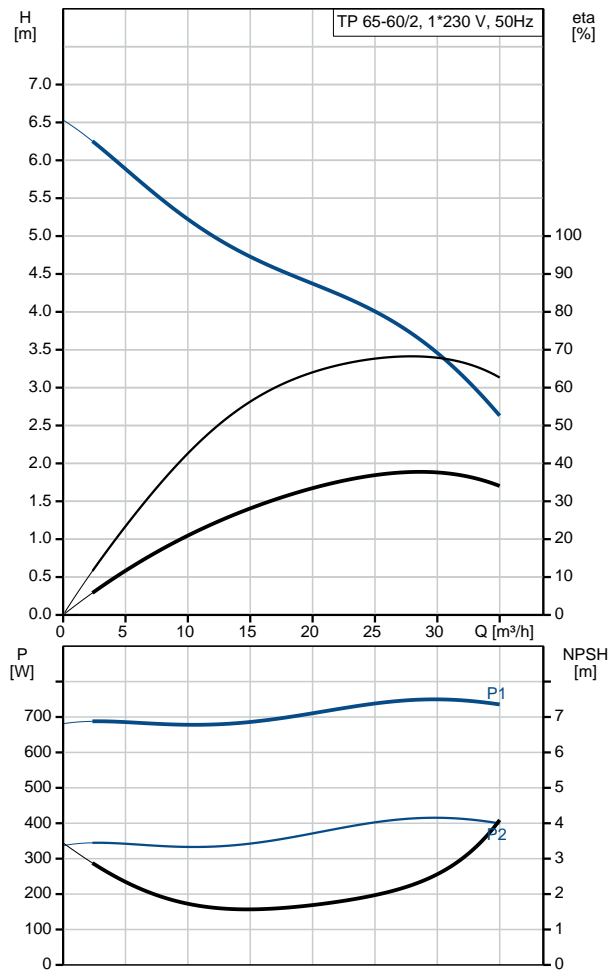

On request TP 65-60/2 A-F-A-BUBE 50 Hz

TP65-60/2 + 80A 0.55 kW 1*230 V, 50 Hz

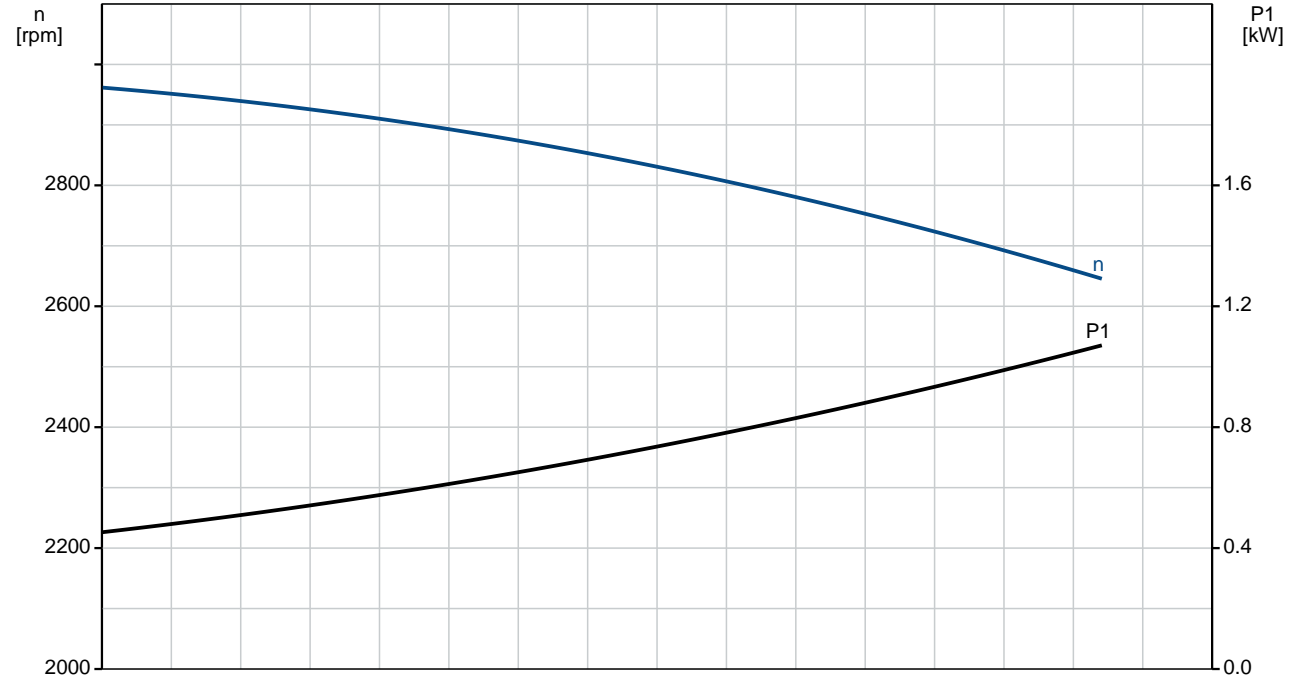
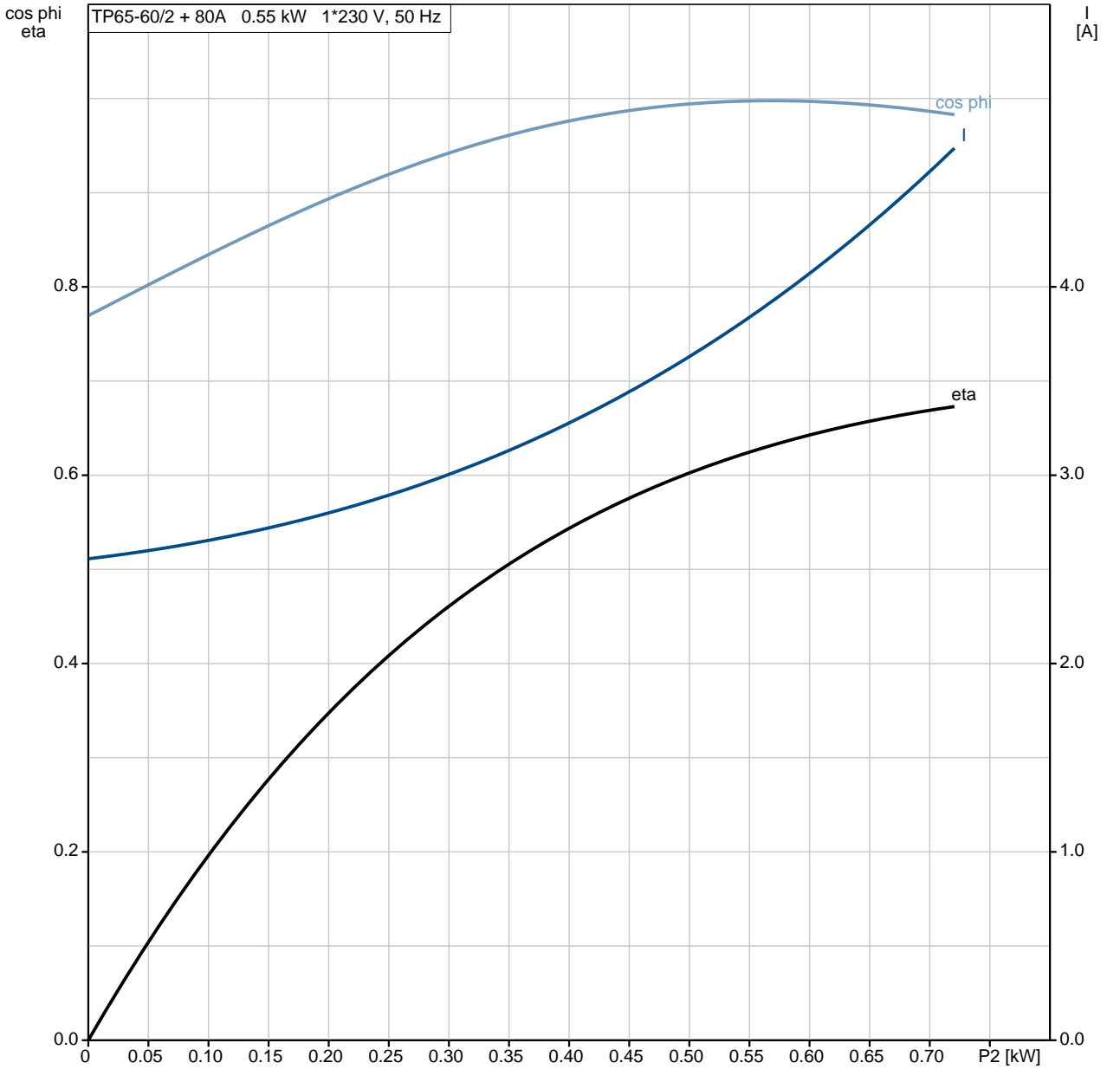

On request TP 65-60/2 A-F-A-BUBE 50 Hz

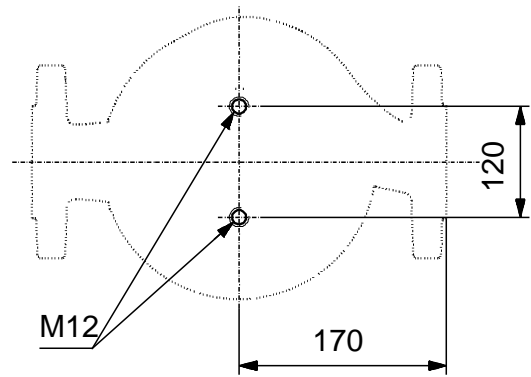
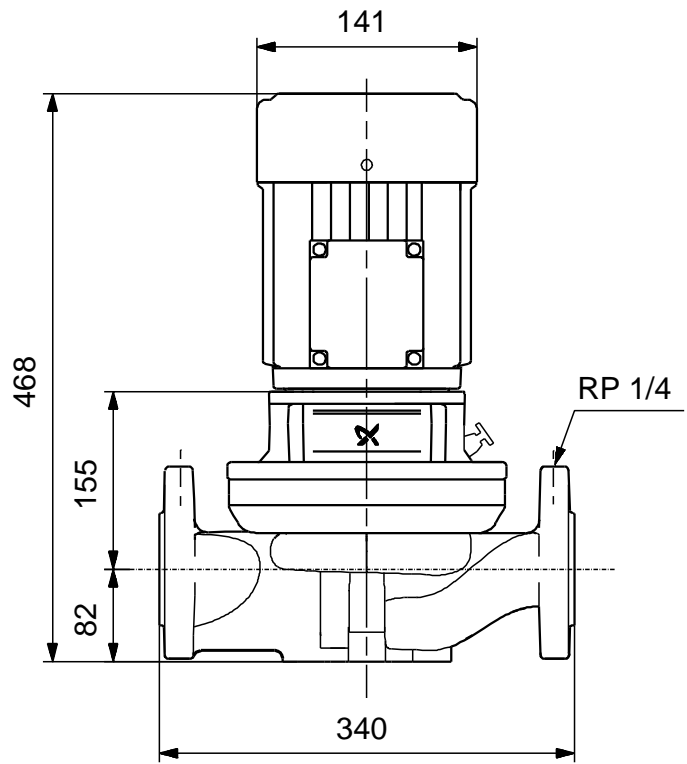
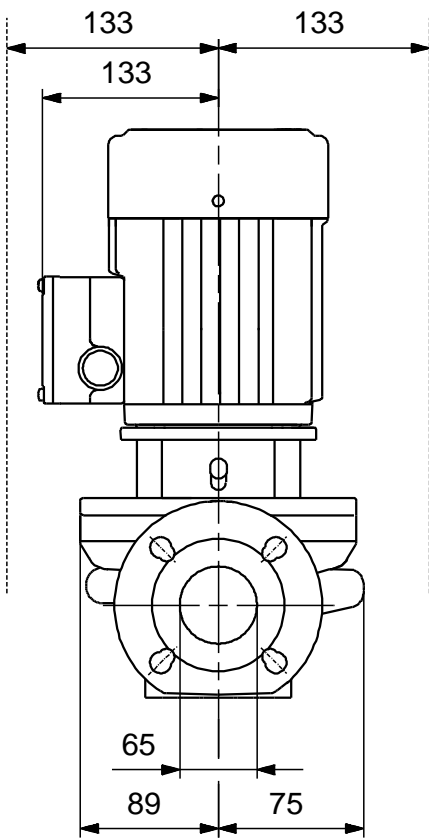

Note! All units are in [mm] unless others are stated.
Disclaimer: This simplified dimensional drawing does not show all details.

Exploded view

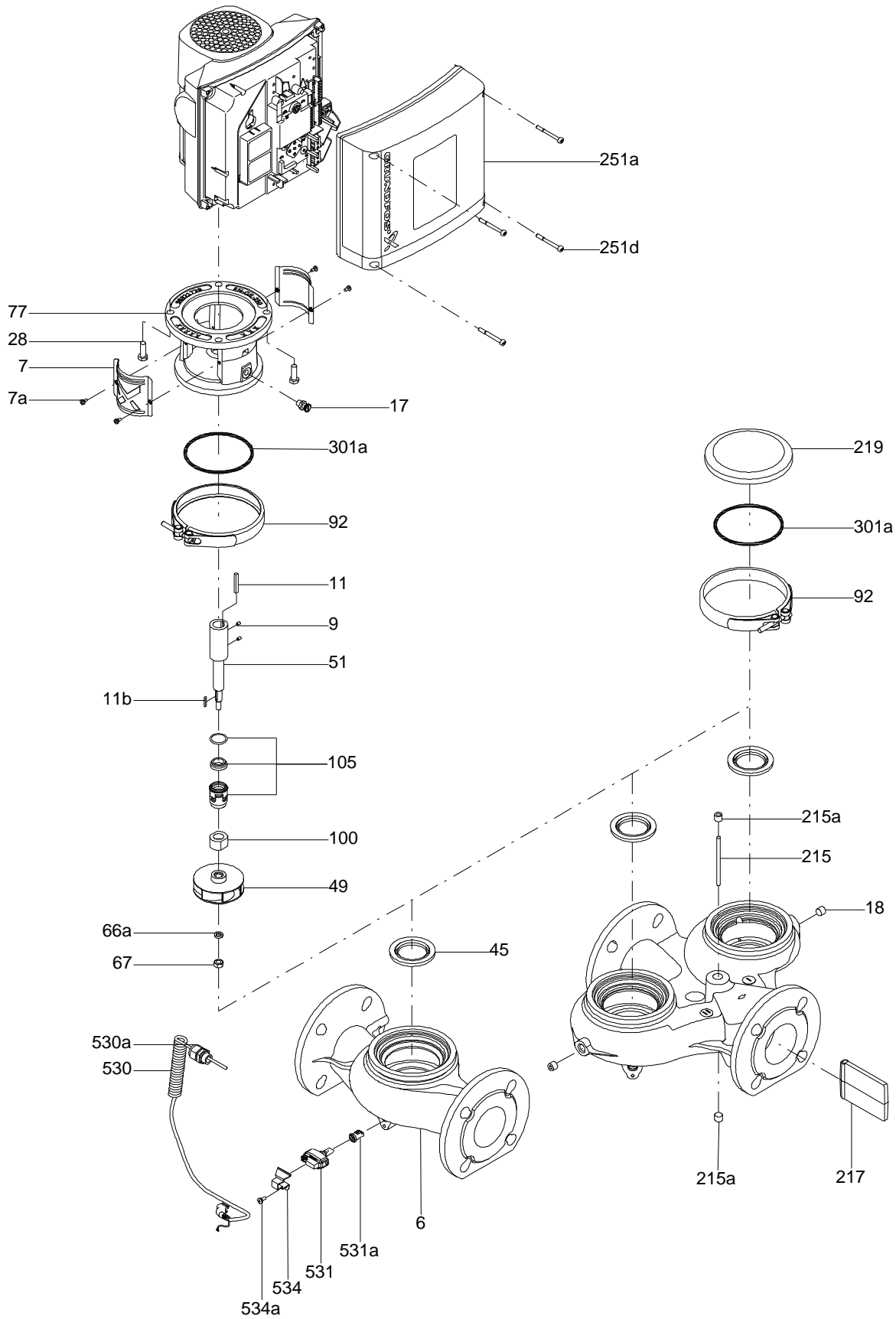

Sectional drawing (TM058200 for TPE2,TPE3)

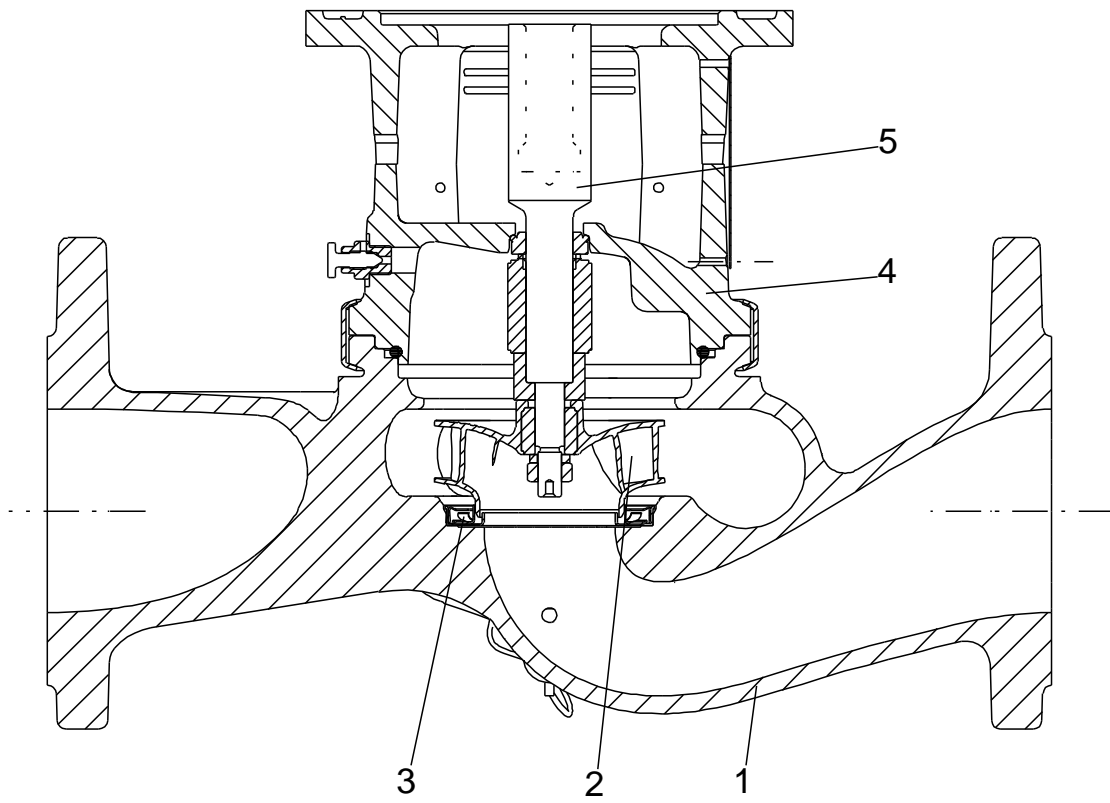

TM058200

Exploded view (TM057026 for MGE model H/I)

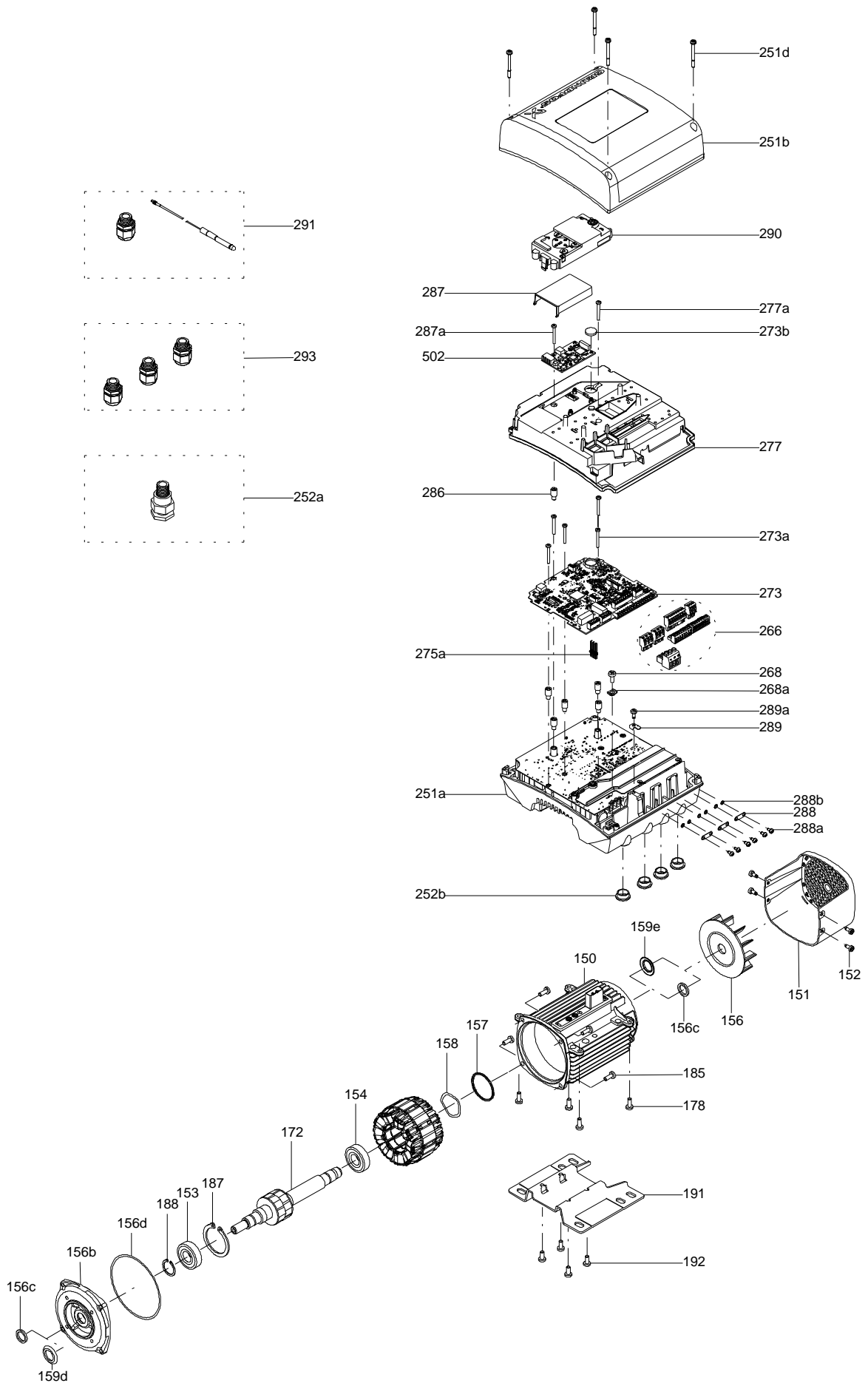

Parts list TP 65-60/2, Product No. On request
Valid from 20.6.2010 (1024)

Pos	Description	Annotation	Données de classification	Référence	Quantité	Unité
+	Motor				1	pcs
-	Coupling cpl.				1	pcs
9	Hex socket head cap screw		Designation: DIN 912 Length (mm): 20 Thread: M6		4	
10	Shaft pin		Diameter: 5 Length (mm): 26		1	
10a	Coupling half				2	
-	Motor stool cpl.				1	pcs
1	Flange				1	
2	Motor stool				1	
24	Cross recess countersunk screw				4	
26	Hex head screw				4	
28	Hex head screw		Length (mm): 20 Thread: M8		4	
-	Pump housing cpl.				1	pcs
- 6	Pump housing				1	
	Pump housing				1	
45	Neck ring				1	
-	Coupling guard cpl.				1	pcs
7	Coupling guard				2	
7a	Pan head screw				4	
-	Shaft w/impeller cpl.				1	pcs
48	Split cone nut				1	
49	Impeller cpl.				1	
49b	Split cone				1	
51	Pump shaft				1	
18	Air vent screw		Thread: 1/4"		1	pcs
19	Plug				2	pcs
72a	O-ring				1	pcs
105	Shaft seal		Material type: EPDM		1	pcs

Disclaimer: The information about the Grundfos pump in this document may be outdated.

Data may be subject to alterations without further notice.

Please contact us to verify the data above is still accurate/up-to-date.

All information is copyright Grundfos.



info@lenntech.com

<https://www.lenntech.com>

tel. +31 152 610 900

fax. +31 152 616 289