

TP 100-70/4-A-F-A-BQQE 1X230 50HZ Grundfos pump 96384313



Thank you for your interest in our products. Please contact us for more information, or visit our website

<https://www.lenntech.com/grundfos/TP000/96384313/TP-100-70-4-A-F-A-BQQE.html>

info@lenntech.com

tel. +31 152 610 900

fax. +31 152 616 289

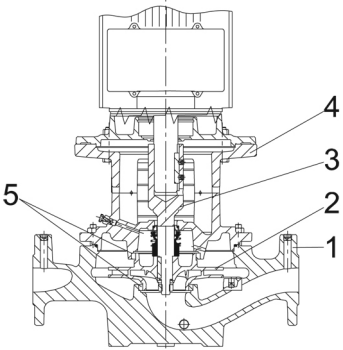
Position	Qty.	Description
	1	<p data-bbox="320 163 614 194">TP 100-70/4 A-F-A-BQQE</p>  <p data-bbox="320 483 600 515">Product No.: On request</p> <p data-bbox="320 544 1445 620">Single-stage, close-coupled, volute pump with in-line suction and discharge ports of identical diameter. The pump is of the top-pull-out design, i.e. the power head (motor, pump head and impeller) can be removed for maintenance or service while the pump housing remains in the pipework.</p> <p data-bbox="320 629 1422 680">The pump is fitted with an unbalanced rubber bellows seal. The shaft seal is according to EN 12756. Pipework connection is via PN 16 DIN flanges (EN 1092-2 and ISO 7005-2).</p> <p data-bbox="320 687 951 719">The pump is fitted with a fan-cooled asynchronous motor.</p> <p data-bbox="320 745 639 777">Further product details</p> <p data-bbox="320 781 1426 857">The product's minimum efficiency index (MEI) is greater or equal to 0.70. This is by the Commission Regulation (EU) considered as an indicative benchmark for best-performing water pump available on the market as from 1 January 2013.</p> <p data-bbox="320 896 403 927">Pump</p> <p data-bbox="320 931 1256 963">Pump housing and pump head are electrocoated to improve the corrosion resistance.</p> <p data-bbox="320 965 584 996">Electrocoating includes:</p> <ol data-bbox="320 999 810 1111" style="list-style-type: none"> 1) Alkaline-based cleaning. 2) Pretreatment with zinc phosphate coating. 3) Cathodic electrocoating (epoxy). 4) Curing of paint film at 200-250 °C.  <ol data-bbox="320 1516 608 1664" style="list-style-type: none"> 1: Pump housing 2: Impeller 3: Stub shaft 4: Pump head/motor stool 5: Wear rings <p data-bbox="320 1693 1461 1747">The pump housing is provided with a replaceable brass neck ring to reduce the amount of liquid running from the outlet side of the impeller to the inlet side. The impeller is secured to the shaft with a nut.</p> <p data-bbox="320 1809 1441 1886">The pump is fitted with an unbalanced rubber bellows seal with torque transmission across the spring and around the bellows. Due to the bellows, the seal does not wear the shaft, and the axial movement is not prevented by deposits on the shaft.</p> <p data-bbox="320 1895 467 1926">Primary seal:</p> <ul data-bbox="357 1924 919 1984" style="list-style-type: none"> • Rotating seal ring material: silicon carbide (SiC) • Stationary seat material: silicon carbide (SiC) <p data-bbox="320 1984 1426 2038">This material pairing is used where higher corrosion resistance is required. The high hardness of this material pairing offers good resistance against abrasive particles.</p> <p data-bbox="320 2040 986 2072">Secondary seal material: EPDM (ethylene-propylene rubber)</p> <p data-bbox="320 2072 1219 2103">EPDM has excellent resistance to hot water. EPDM is not suitable for mineral oils.</p>

Position	Qty.	Description
		<p>A circulation of liquid through the duct of the air vent screw ensures lubrication and cooling of the shaft seal.</p> <p>The flanges have tappings for mounting of pressure gauges.</p> <p>The motor stool forms connection between the pump housing and the motor, and is equipped with a manual air vent screw for venting of the pump housing and the shaft seal chamber. The sealing between motor stool and pump housing is an O-ring.</p> <p>The central part of the motor stool is provided with guards for protection against the shaft and coupling. The pump shaft is fastened directly on the motor shaft with key and set screws.</p> <p>Motor</p> <p>The motor is a totally enclosed, fan-cooled motor with principal dimensions to IEC and DIN standards. Electrical tolerances comply with IEC 60034.</p> <p>The motor is flange-mounted with free-hole flange (FF). Motor-mounting designation in accordance with IEC 60034-7: IM B 5, IM V 1 (Code I) / IM 3001, IM 3011 (Code II).</p> <p>The motor has built-in thermal protection (PTO current and temperature sensors) in accordance with IEC 60034-11 and requires no further motor protection. The protection reacts to both slow- and quick-rising temperatures, e.g. constant overload and stalled conditions.</p> <p>As the thermal protection incorporates automatic reset, the motor must be connected in a way which ensures that the automatic reset cannot cause accidents.</p> <p>Technical data</p> <p>Liquid: Pumped liquid: Water Liquid temperature range: -25 .. 120 °C Liquid temperature during operation: 20 °C Density: 998.2 kg/m³</p> <p>Technical: Rated flow: 79.1 m³/h Rated head: 4.75 m Actual impeller diameter: 150 mm Primary shaft seal: BQQE Curve tolerance: ISO9906:2012 3B</p> <p>Materials: Pump housing: Cast iron EN-JL1040 ASTM A48-40 B Impeller: Cast iron EN-JL1030 ASTM A48-30 B</p> <p>Installation: Range of ambient temperature: -30 .. 40 °C Maximum operating pressure: 16 bar Flange standard: DIN Pipe connection: DN 100 Pump inlet: DN 100 Pump outlet: DN 100 Pressure rating: PN 16 (@): 550 mm Flange size for motor: FF165</p> <p>Electrical data: Motor type: 90LC Rated power - P2: 1.5 kW Power (P2) required by pump: 1.5 kW Mains frequency: 50 Hz Rated voltage: 1 x 220-230 V Rated current: 9.9 A</p>

Position	Qty.	Description
		<p>Starting current: 400 %</p> <p>Cos phi - power factor: 0.97</p> <p>Rated speed: 1390-1400 rpm</p> <p>Motor efficiency at full load: 74-73 %</p> <p>Number of poles: 4</p> <p>Enclosure class (IEC 34-5): 55 Dust/Jetting</p> <p>Insulation class (IEC 85): F</p> <p>Others:</p> <p>Minimum efficiency index, MEI : 0.70</p> <p>ErP status: EuP Standalone/Prod.</p> <p>Net weight: 95 kg</p> <p>Gross weight: 114 kg</p> <p>Shipping volume: 0.39 m³</p>

On request TP 100-70/4 A-F-A-BQQE 50 Hz

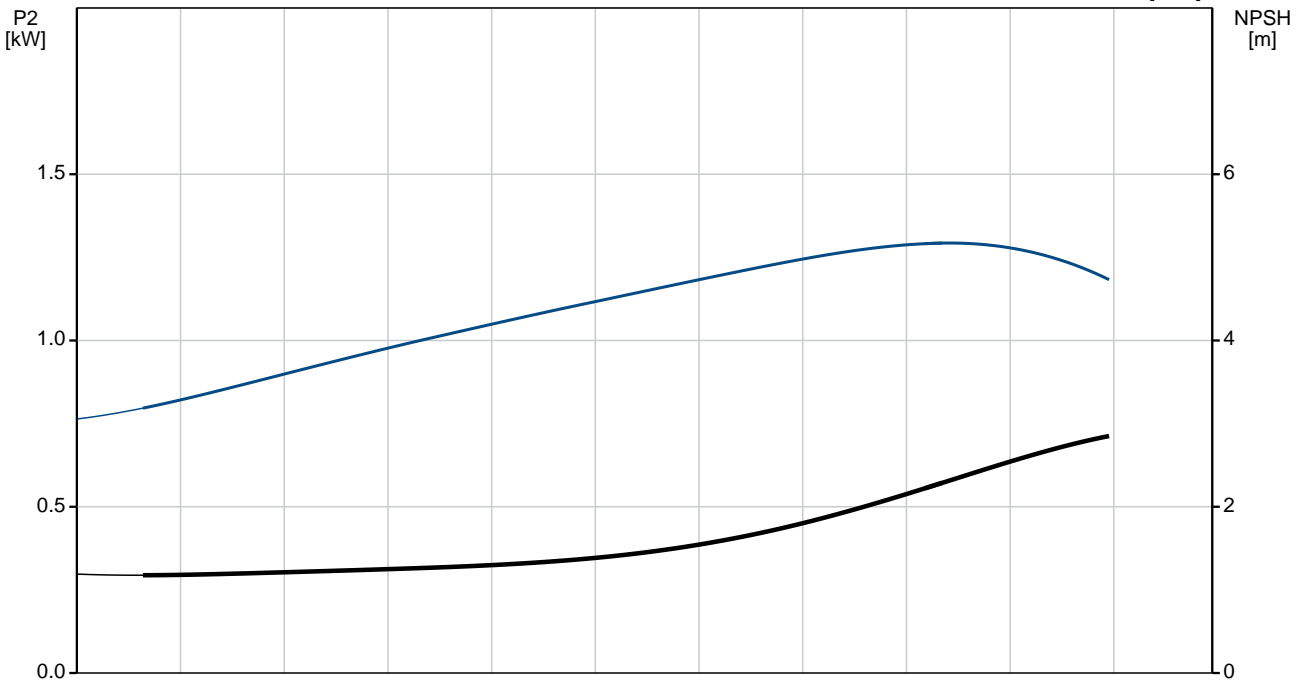
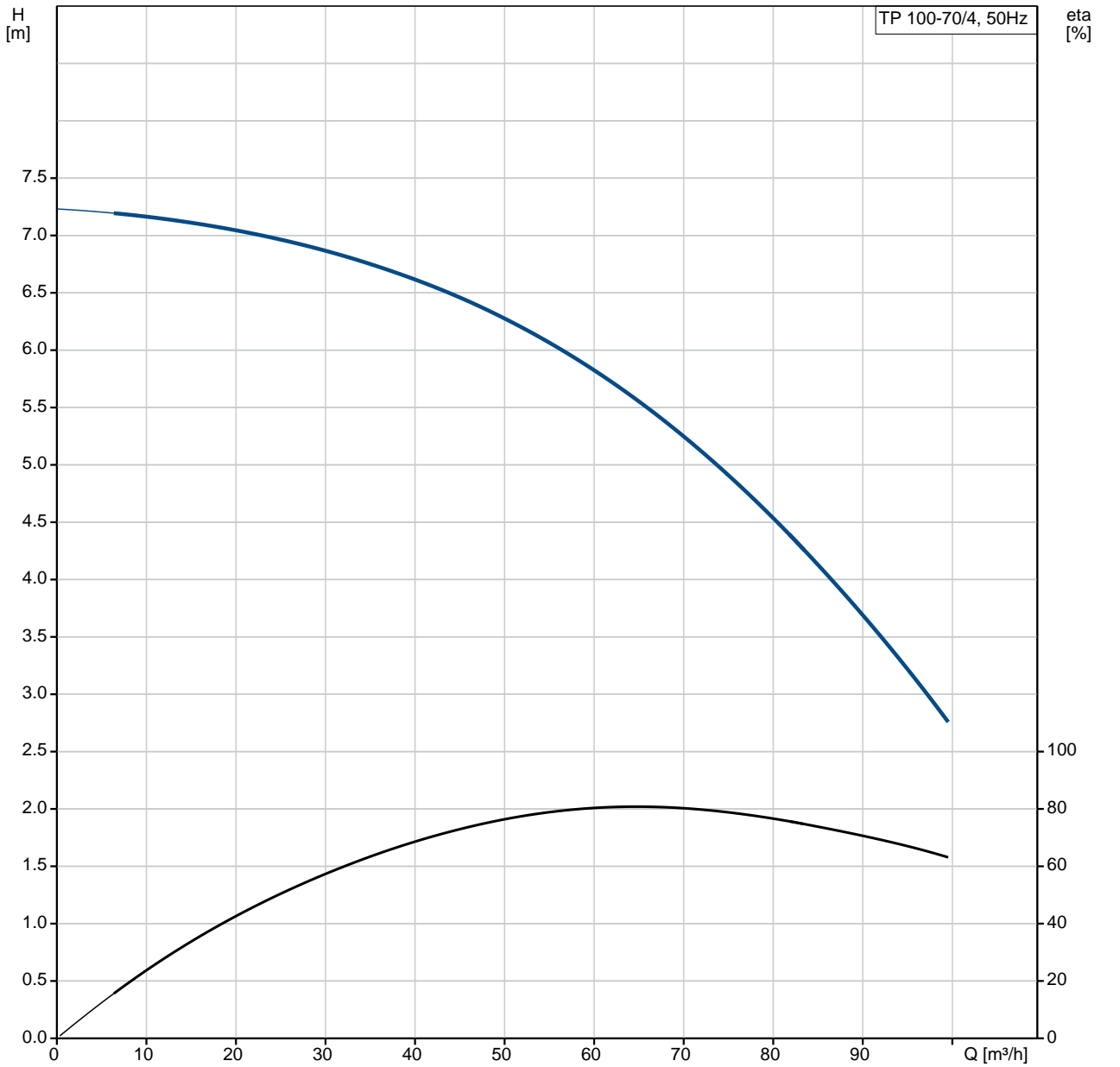

Description	Value
General information:	
Product name:	TP 100-70/4 A-F-A-BQQE
Product No:	On request
EAN number:	On request
Technical:	
Rated flow:	79.1 m ³ /h
Rated head:	4.75 m
Head max:	70 dm
Actual impeller diameter:	150 mm
Primary shaft seal:	BQQE
Curve tolerance:	ISO9906:2012 3B
Pump version:	A
Model:	A
Materials:	
Pump housing:	Cast iron EN-JL1040 ASTM A48-40 B
Impeller:	Cast iron EN-JL1030 ASTM A48-30 B
Material code:	A
Installation:	
Range of ambient temperature:	-30 .. 40 °C
Maximum operating pressure:	16 bar
Flange standard:	DIN
Pipe connection:	DN 100
Pump inlet:	DN 100
Pump outlet:	DN 100
Pressure rating:	PN 16
(@)	550 mm
Flange size for motor:	FF165
Connect code:	F
Liquid:	
Pumped liquid:	Water
Liquid temperature range:	-25 .. 120 °C
Liquid temperature during operation:	20 °C
Density:	998.2 kg/m ³
Electrical data:	
Motor type:	90LC
Rated power - P2:	1.5 kW
Power (P2) required by pump:	1.5 kW
Mains frequency:	50 Hz
Rated voltage:	1 x 220-230 V
Rated current:	9.9 A
Starting current:	400 %
Cos phi - power factor:	0.97
Rated speed:	1390-1400 rpm
Motor efficiency at full load:	74-73 %
Number of poles:	4
Enclosure class (IEC 34-5):	55 Dust/Jetting
Insulation class (IEC 85):	F
Motor protec:	PTO
Motor No:	87200344
Others:	
Minimum efficiency index, MEI :	0.70
ErP status:	EuP Standalone/Prod.
Net weight:	95 kg
Gross weight:	114 kg
Shipping volume:	0.39 m ³

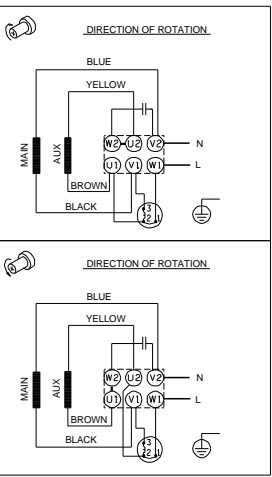
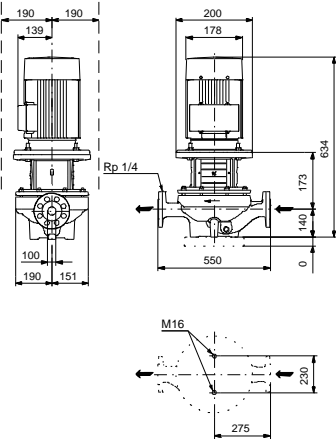
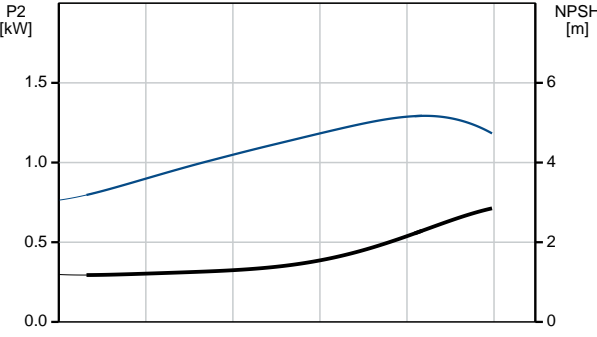
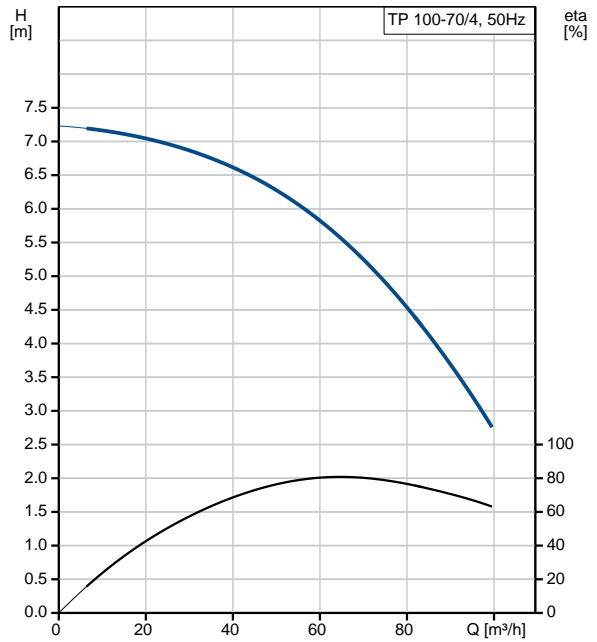

On request TP 100-70/4 A-F-A-BQQE 50 Hz

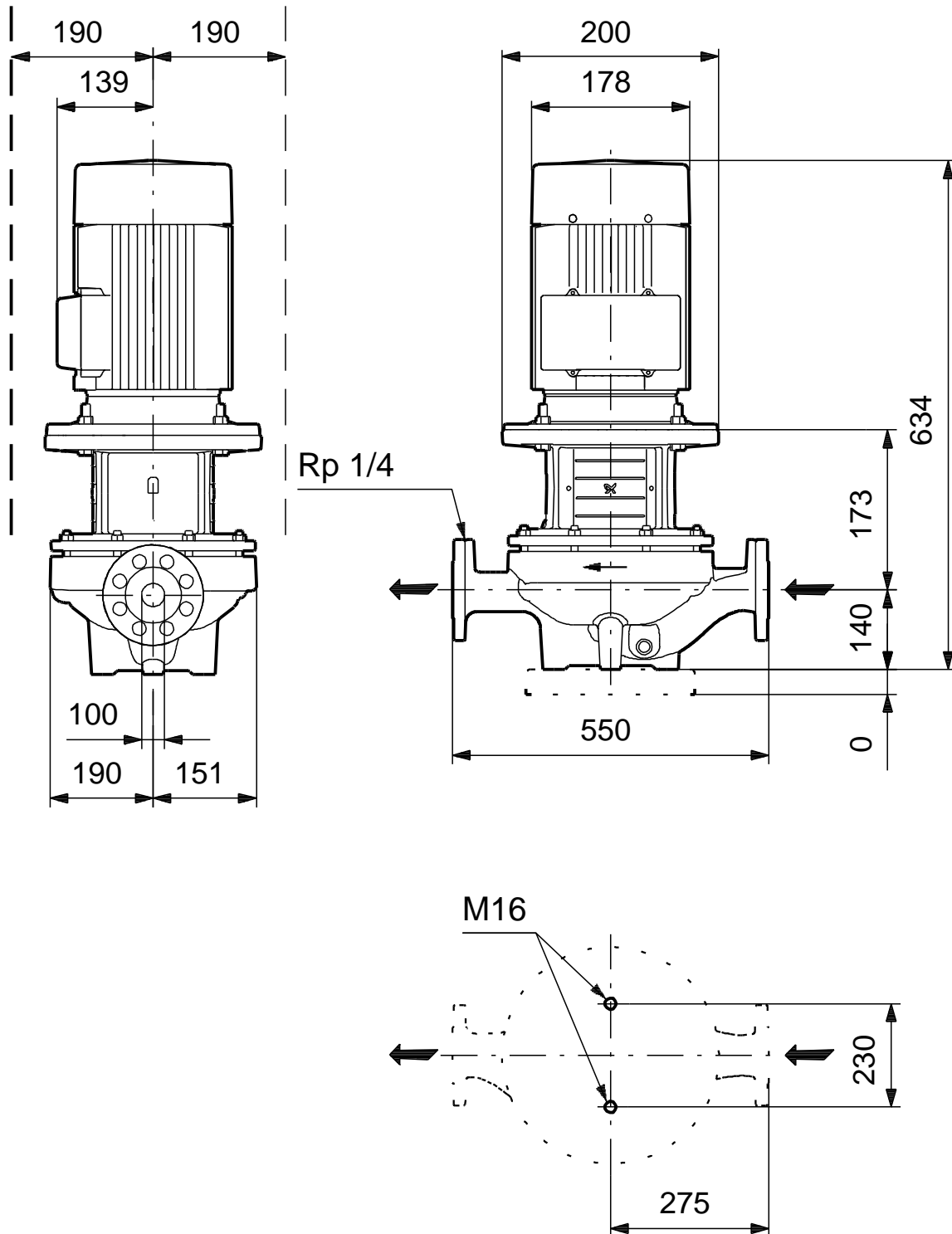

Note! All units are in [mm] unless others are stated.
Disclaimer: This simplified dimensional drawing does not show all details.

Exploded view

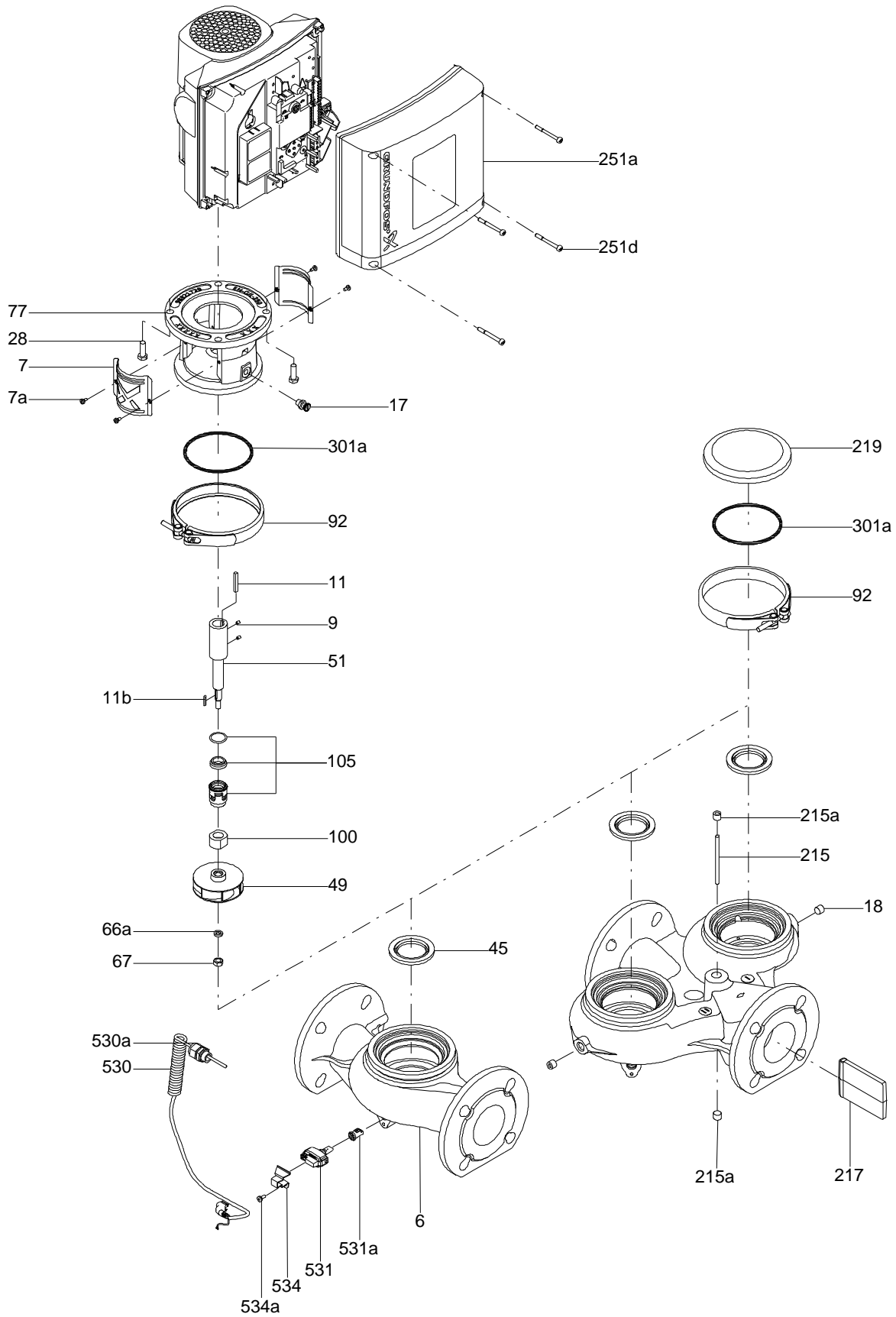

Sectional drawing (TM058200 for TPE2,TPE3)

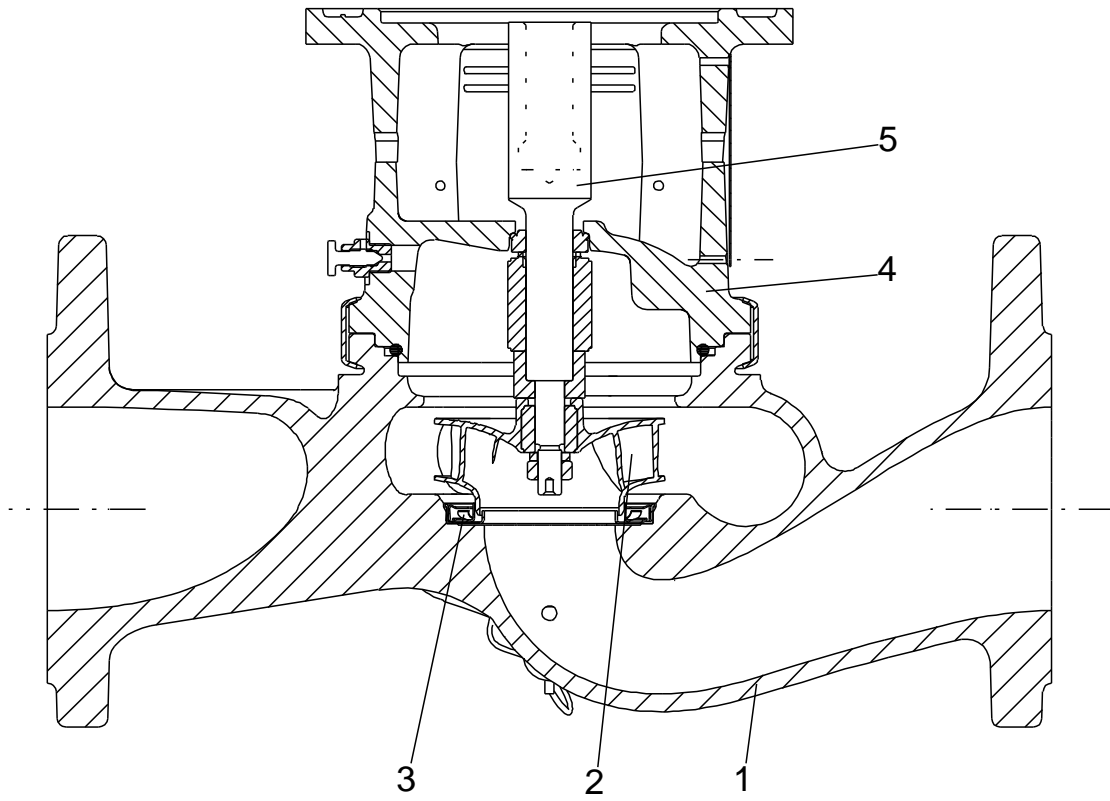

TM058200

Exploded view (TM057026 for MGE model H/I)

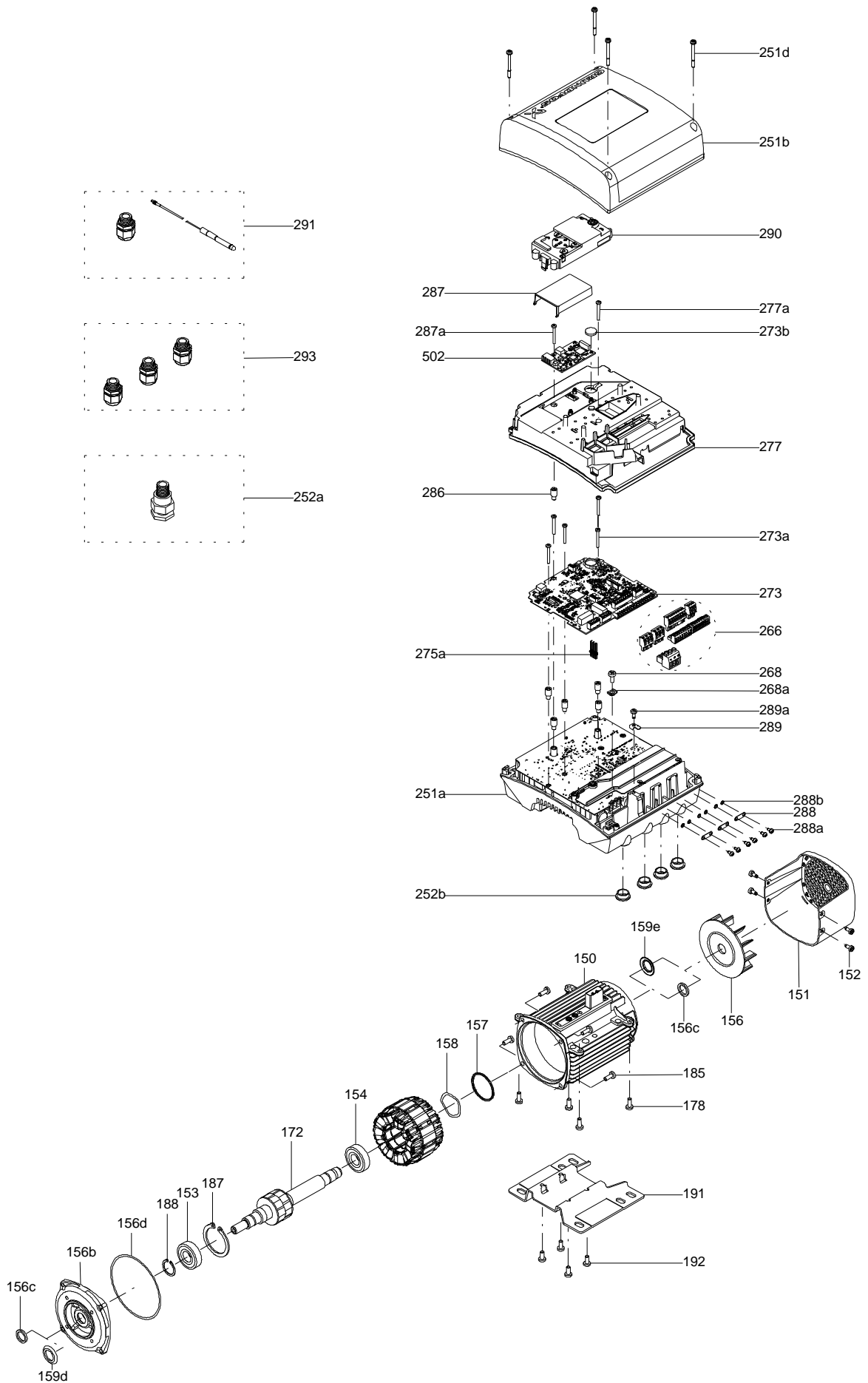

Parts list TP 100-70/4, Product No. On request
Valid from 1.5.2004 (0418)

Pos	Description	Annotation	Données de classification	Référence	Quantité	Unité
+	Motor				1	pcs
-	Motor stool cpl.				1	pcs
2a	Motor stool				1	
7	Coupling guard				2	
9	Hex socket head cap screw		Designation: DIN 912		4	
			Length (mm): 25			
			Thread: M10			
9	Socket set screw				2	
11	Parallel key		Dimension: 6X6X35		1	
17	Air vent screw				1	
51	Pump shaft				1	
76	Plate				1	
76a	Rivet				2	
77a	Pan head screw				4	
-	Shaft seal cpl.				1	pcs
72a	O-ring		Diameter: 177,39		1	
			Material type: EPDM			
			Thickness: 3,53			
105	Shaft seal		Material type: BAQE		1	
-	49a Impeller cpl.				1	pcs
49	Impeller				1	
66	Washer				1	
66a	Spring lock washer				1	
67	Nut		Thread: M14		1	
-	50 Pump housing cpl.				1	pcs
-	6 Pump housing w/wear ring				1	
	Pump housing				1	
26	Staybolt		Length (mm): 35		6	
			Thread: M10			
45	Wear ring				1	
19	Plug				1	
20	Plug				1	
36	Nut		Thread: M10		6	

Disclaimer: The information about the Grundfos pump in this document may be outdated.

Data may be subject to alterations without further notice.

Please contact us to verify the data above is still accurate/up-to-date.

All information is copyright Grundfos.



info@lenntech.com

<https://www.lenntech.com>

tel. +31 152 610 900

fax. +31 152 616 289