

CRT16-14 A-P-A-E-AUUE 3x380-415DV, 50Hz Grundfos pump 96117253



Thank you for your interest in our products. Please contact us for more information, or visit our website

<https://www.lenntech.com/grundfos/CRT16/96117253/CRT-16-14-A-P-A-E-AUUE.html>

info@lenntech.com

tel. +31 152 610 900

fax. +31 152 616 289

Position	Qty.	Description
	1	<p data-bbox="322 161 622 192">CRT 16-14 A-P-A-E-AUUE</p>  <p data-bbox="322 483 842 600">Product No.: On request Vertical, non-self-priming, multistage, in-line, centrifugal pump for installation in pipe systems and mounting on a foundation.</p> <p data-bbox="322 631 948 927">The pump has the following characteristics:</p> <ul data-bbox="354 663 948 896" style="list-style-type: none"> - Impellers, intermediate chambers and outer sleeve are made of Titanium. - Pump head cover and base are made of Titanium. - The shaft seal has assembly length according to EN 12756. - Power transmission is via cast iron split coupling. - Pipework connection is via PJE flanges/couplings. <p data-bbox="322 958 695 990">The motor is a 3-phase AC motor.</p> <p data-bbox="322 1021 405 1048">Liquid:</p> <p data-bbox="322 1052 823 1169">Pumped liquid: Water Liquid temperature range: -20 .. 120 °C Liquid temperature during operation: 20 °C Density: 998.2 kg/m³</p> <p data-bbox="322 1200 443 1227">Technical:</p> <p data-bbox="322 1232 880 1375">Rated flow: 16 m³/h Rated head: 154 m Primary shaft seal: AUUE Approvals on nameplate: CE, TR Curve tolerance: ISO9906:2012 3B</p> <p data-bbox="322 1406 437 1433">Materials:</p> <p data-bbox="322 1438 826 1581">Pump housing: Titanium ASTM B 265 Impeller: Titanium ASTM B 265 Bush material: NONE</p> <p data-bbox="322 1612 459 1639">Installation:</p> <p data-bbox="322 1644 858 1823">Maximum ambient temperature: 60 °C Max pressure at stated temp: 25 bar / 120 °C 25 bar / -20 °C Flange standard: PJE Pipe connection: 60,3 mm Flange size for motor: FF300</p> <p data-bbox="322 1854 497 1881">Electrical data:</p> <p data-bbox="322 1886 970 2092">Motor type: 160MD IE Efficiency class: IE3 Rated power - P2: 15 kW Power (P2) required by pump: 15 kW 15 kW Mains frequency: 50 Hz Rated voltage: 3 x 380-415D/660-690Y V</p>

Position	Qty.	Description
		<p>Rated current: 28,0-26,0/16,2-15,6 A</p> <p>Starting current: 660-780 %</p> <p>Cos phi - power factor: 0.89-0.87</p> <p>Rated speed: 2930-2950 rpm</p> <p>Efficiency: IE3 91,9%</p> <p>Motor efficiency at full load: 91.9-91.9 %</p> <p>Motor efficiency at 3/4 load: 92.4 %</p> <p>Motor efficiency at 1/2 load: 92.4 %</p> <p>Number of poles: 2</p> <p>Enclosure class (IEC 34-5): 55 Dust/Jetting</p> <p>Insulation class (IEC 85): F</p> <p>Others:</p> <p>Minimum efficiency index, MEI : 0.69</p> <p>Net weight: 136 kg</p> <p>Gross weight: 146 kg</p>

On request CRT 16-14 A-P-A-E-AUUE 50 Hz

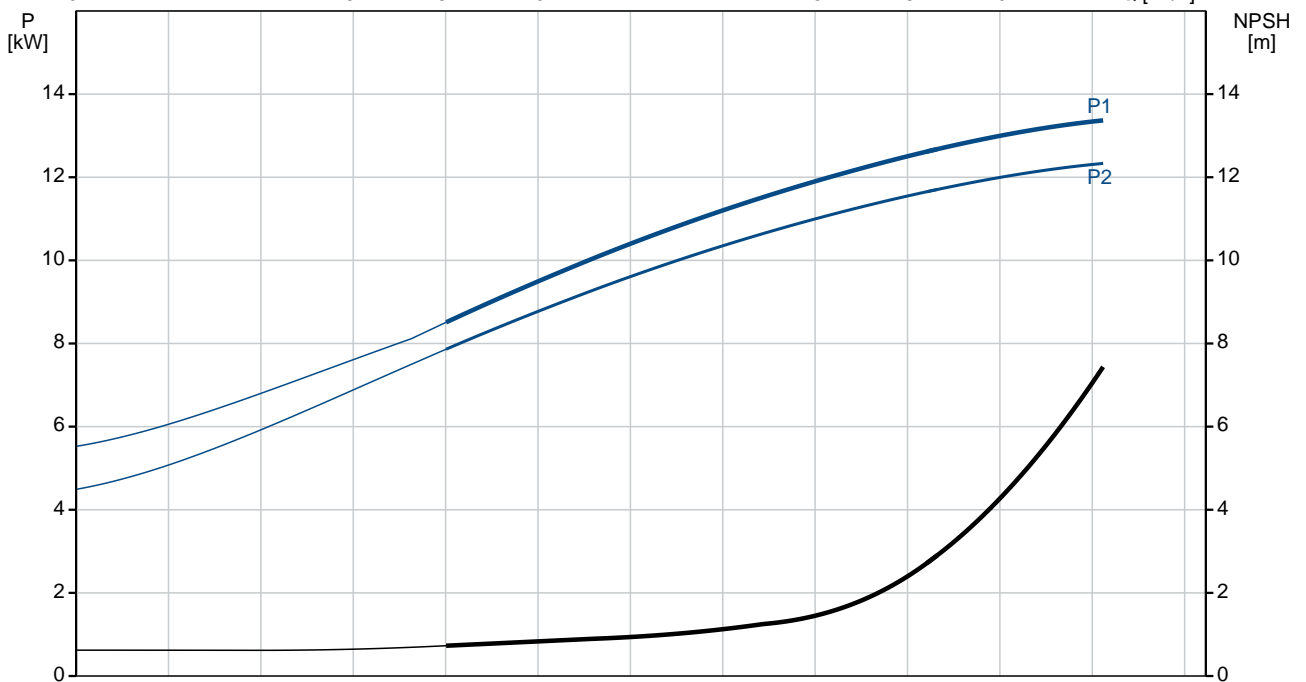
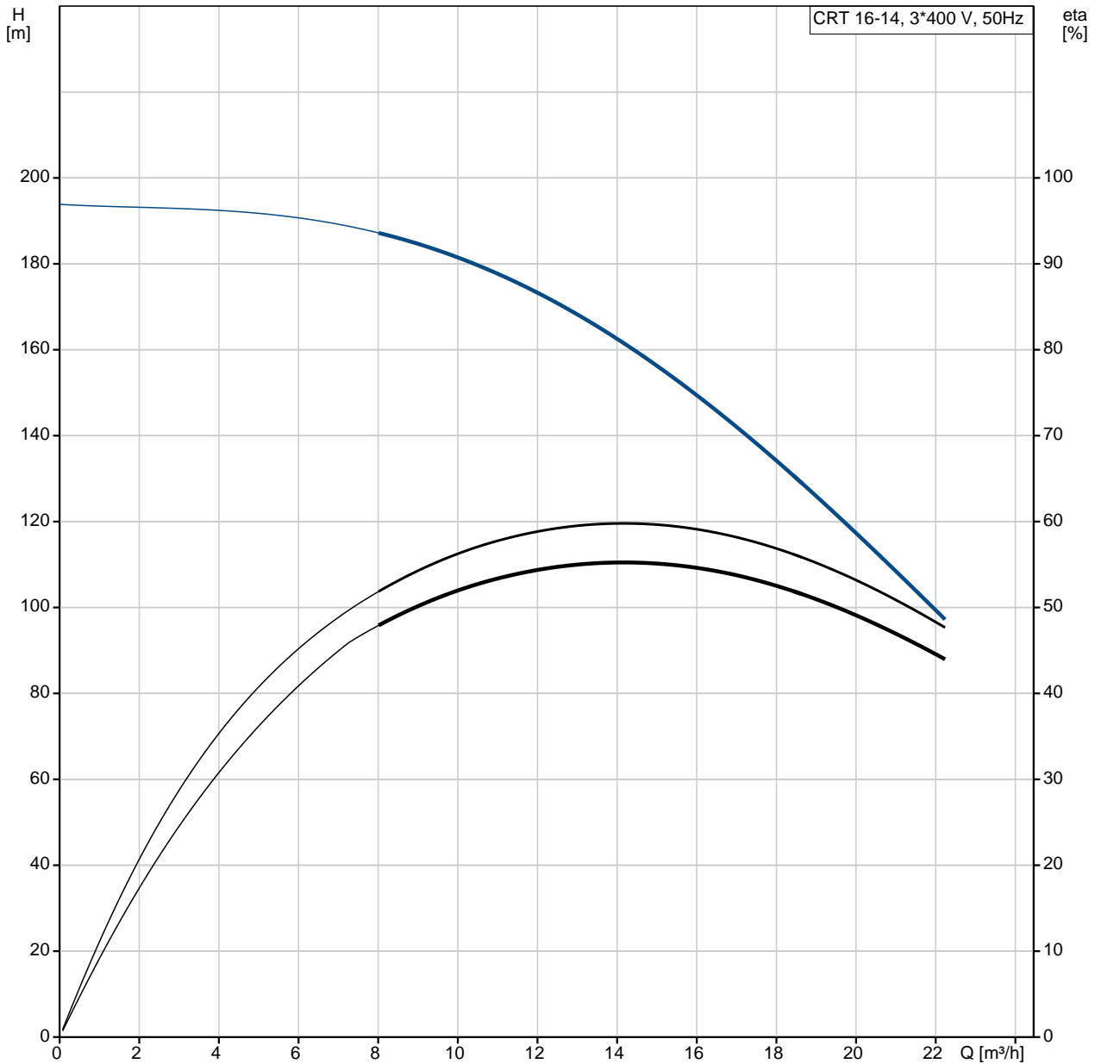

Description	Value
General information:	
Product name:	CRT 16-14 A-P-A-E-AUUE
Product No:	On request
EAN number:	On request
Technical:	
Rated flow:	16 m ³ /h
Rated head:	154 m
Head max:	203.4 m
Stages:	14
Impellers:	14
Primary shaft seal:	AUUE
Approvals on nameplate:	CE, TR
Curve tolerance:	ISO9906:2012 3B
Pump version:	A
Model:	A
Materials:	
Pump housing:	Titanium ASTM B 265
Impeller:	Titanium ASTM B 265
Material code:	A
Code for rubber:	E
Bush material:	NONE
Installation:	
Maximum ambient temperature:	60 °C
Max pressure at stated temp:	25 bar / 120 °C 25 bar / -20 °C
Flange standard:	PJE
Pipe connection:	60,3 mm
Flange size for motor:	FF300
Connect code:	P
Liquid:	
Pumped liquid:	Water
Liquid temperature range:	-20 .. 120 °C
Liquid temperature during operation:	20 °C
Density:	998.2 kg/m ³
Electrical data:	
Motor type:	160MD
IE Efficiency class:	IE3
Rated power - P2:	15 kW
Power (P2) required by pump:	15 kW
Mains frequency:	50 Hz
Rated voltage:	3 x 380-415D/660-690Y V
Rated current:	28,0-26,0/16,2-15,6 A
Starting current:	660-780 %
Cos phi - power factor:	0.89-0.87
Rated speed:	2930-2950 rpm
Efficiency:	IE3 91,9%
Motor efficiency at full load:	91.9-91.9 %
Motor efficiency at 3/4 load:	92.4 %
Motor efficiency at 1/2 load:	92.4 %
Number of poles:	2
Enclosure class (IEC 34-5):	55 Dust/Jetting
Insulation class (IEC 85):	F
Motor protec:	PTC
Motor No:	85U17526
Others:	
Minimum efficiency index, MEI :	0.69
Net weight:	136 kg
Gross weight:	146 kg

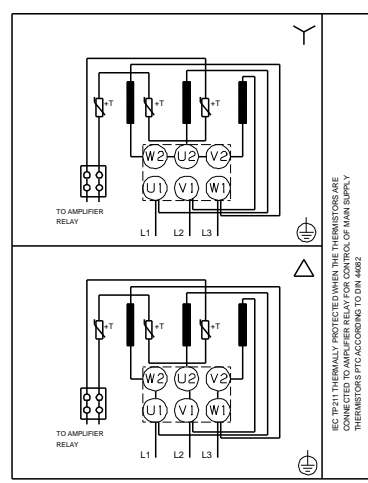
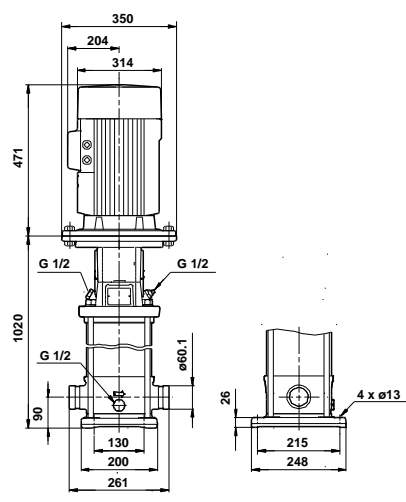
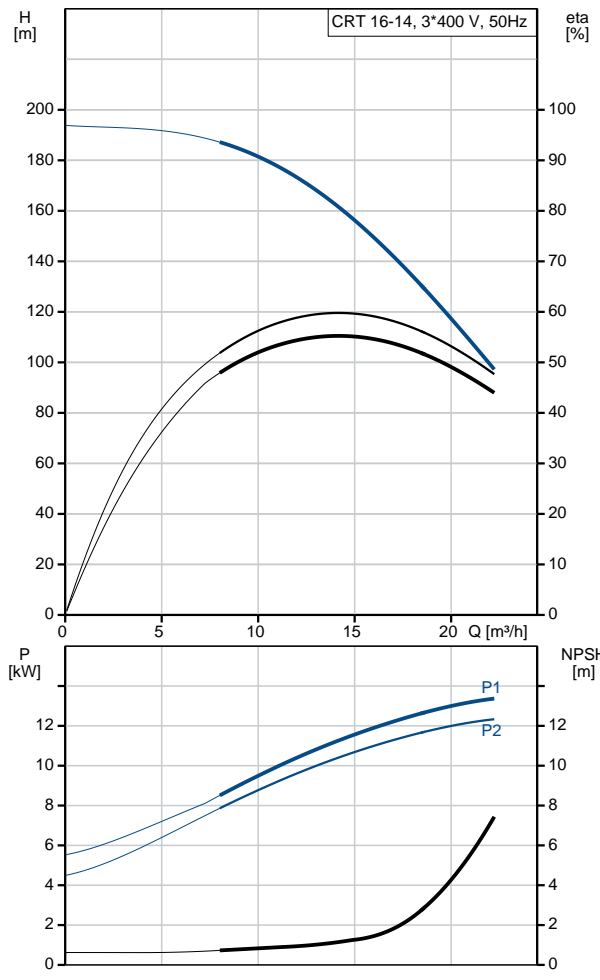

On request CRT 16-14 A-P-A-E-AUUE 50 Hz

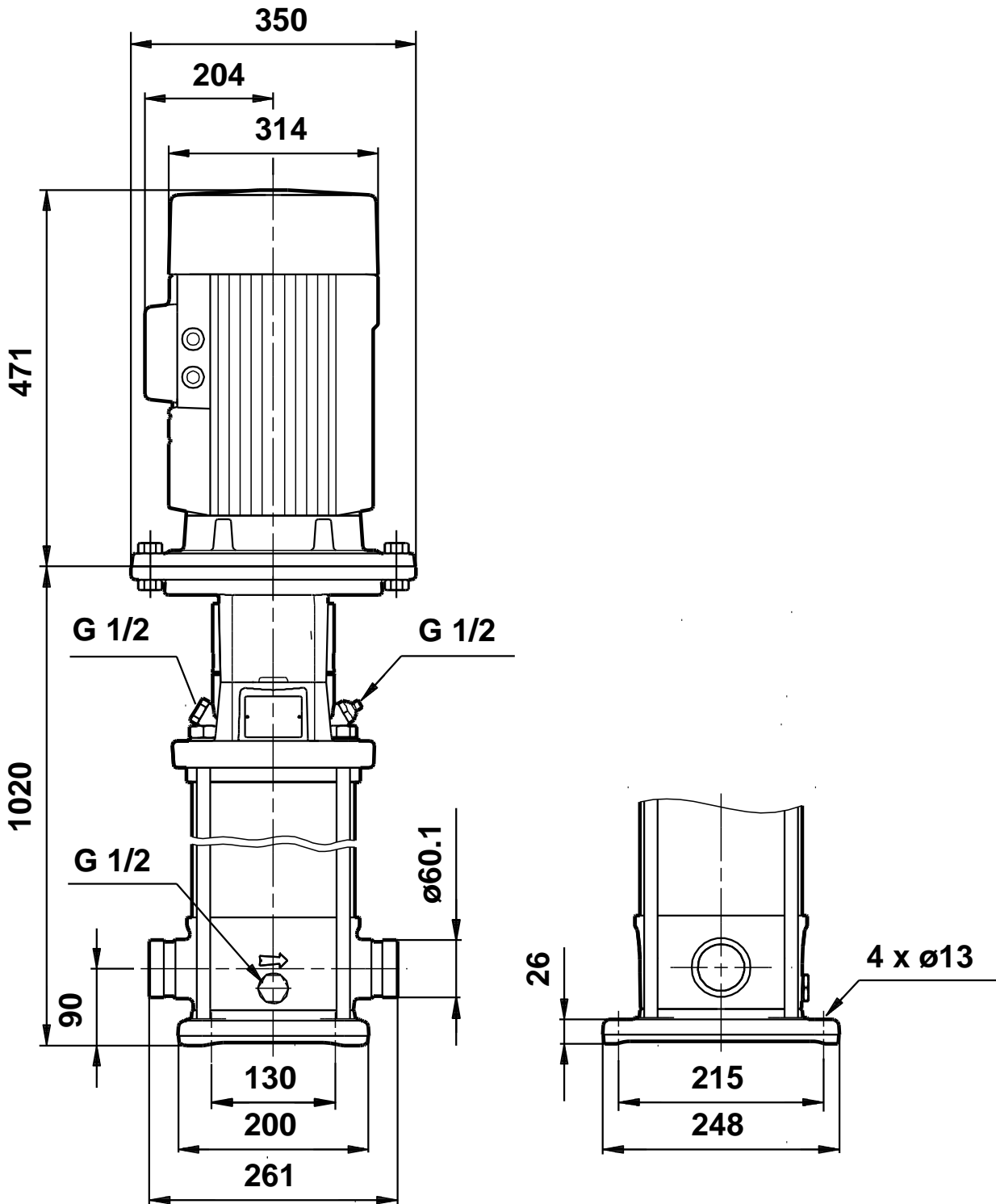

Note! All units are in [mm] unless others are stated.
Disclaimer: This simplified dimensional drawing does not show all details.

Exploded view

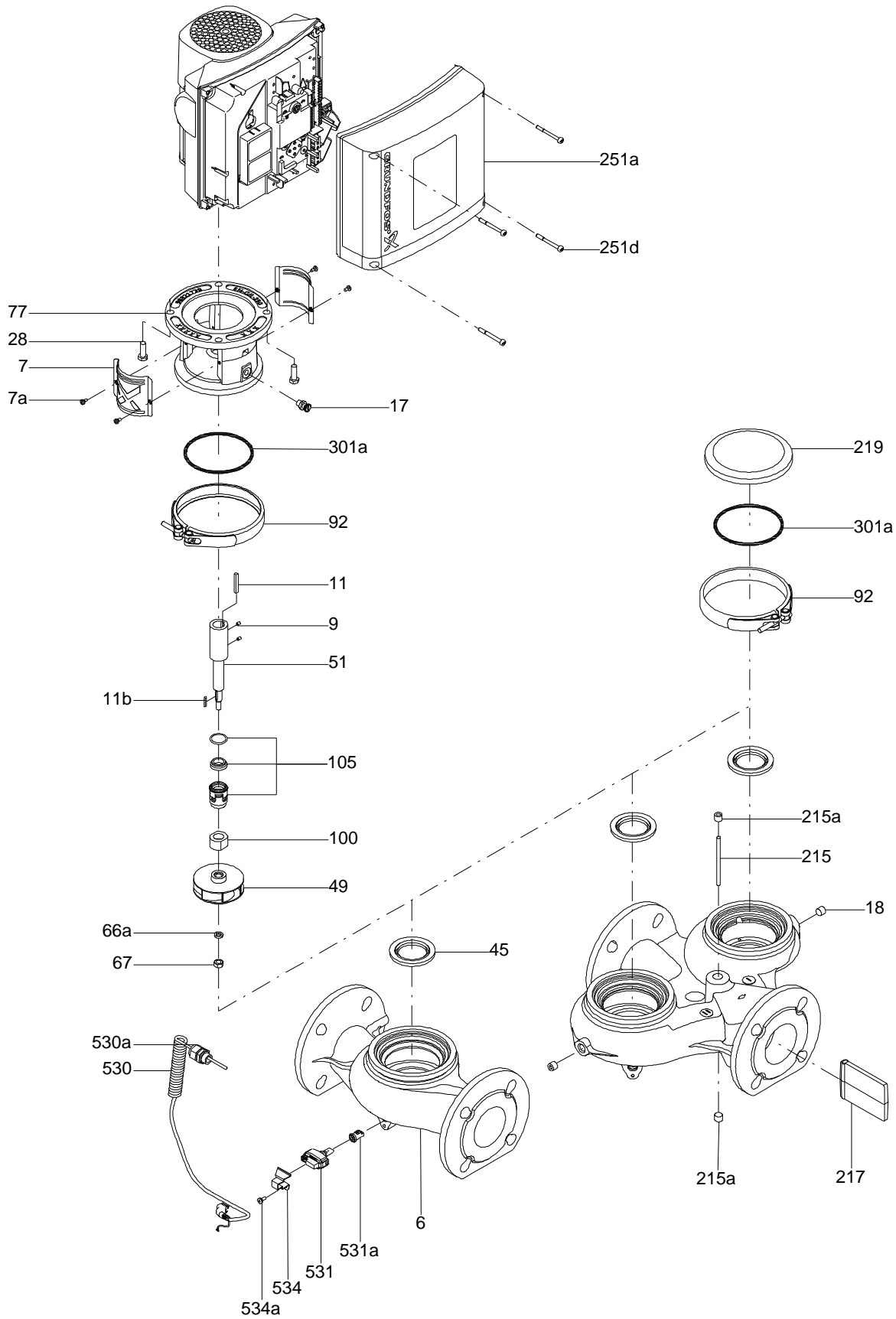

Sectional drawing (TM058200 for TPE2,TPE3)



TM058200

Exploded view (TM057026 for MGE model H/I)

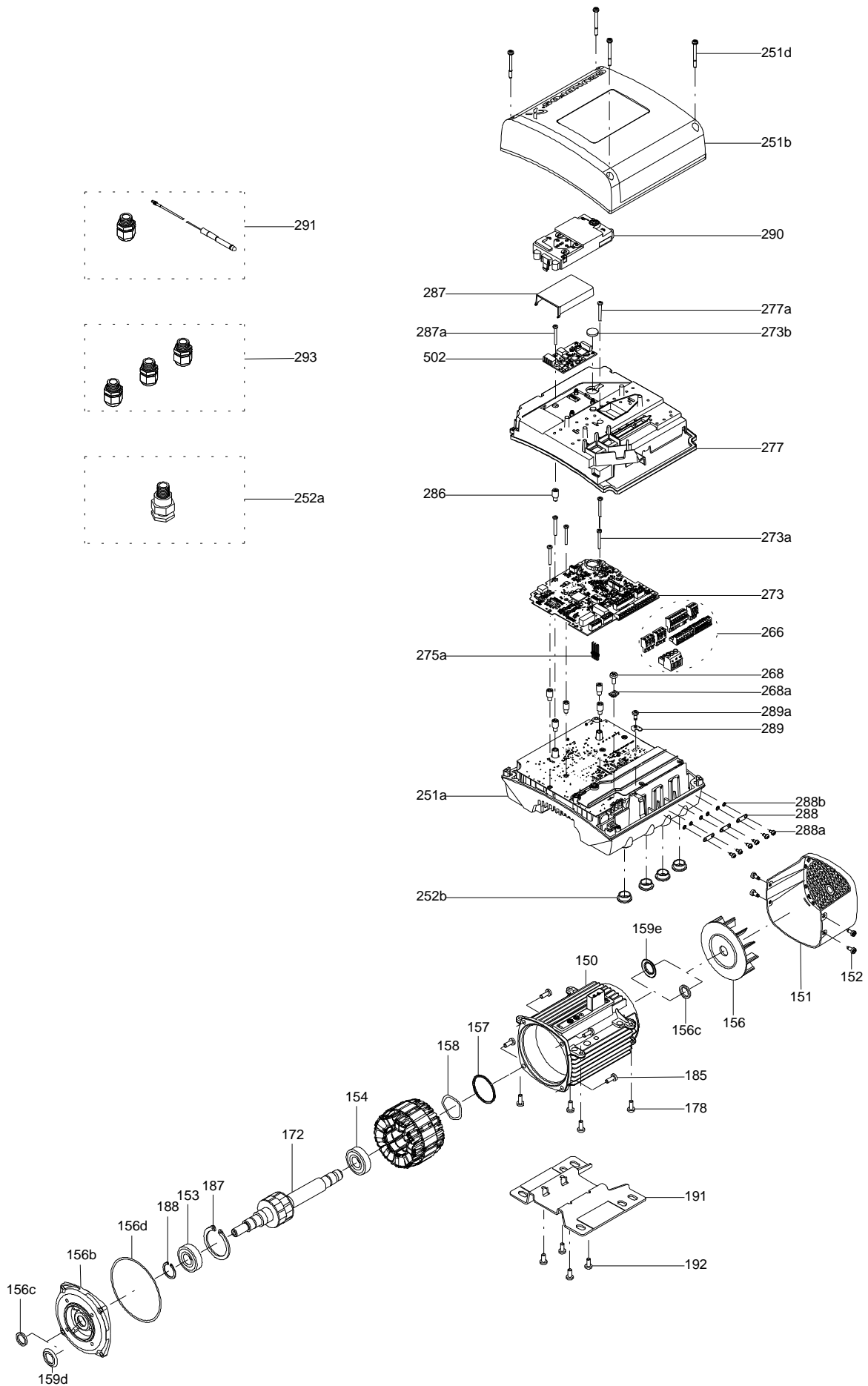

Parts list CRT 16-14, Product No. On request
Valid from 1.4.2011 (1113)

Pos	Description	Annotation	Données de classification	Référence	Quantité	Unité
+	Motor				1	pcs
-	Base cpl.				1	pcs
6	Base				1	
25	Drain plug				1	
56	Base plate				1	
-	Pump head cpl.				1	pcs
1	Flange				1	
2	Pump head				1	
7	Coupling guard				2	
7a	Combi Slot Torx screw				4	
- 8	Coupling				1	
9	Hex socket head cap screw		Designation: DIN 912		4	
			Length (mm): 25			
			Thread: M10			
10	Shaft pin		Diameter: 5		1	
			Length (mm): 26			
10a	Coupling		Dimension: Å 90X90		1	
			Type: NEMA			
18	Air vent screw		Thread: RG 1/2		1	
23	Plug				1	
28	Hex head screw		Length (mm): 25		4	
			Thread: M12			
28a	Hex head screw		Length (mm): 45		4	
			Thread: M16			
36	Nut		Thread: M16		4	
36	Hex nut		Thread: M16		4	
37	O-ring				1	
66a	Washer		Designation: DIN 125 A2		4	
			Internal diameter: 17			
			Outer diameter: 30			
			Thickness: 3			
77	Pump head cover				1	
107	Plug				1	
-	Rubber module, EPDM				1	pcs
20	Spring				4	
37	O-ring				2	
38	O-ring		Diameter: 5,3		1	
			Material type: EPDM			
			Thickness: 2,4			
100	O-ring		Diameter: 16,3		2	
			Material type: EPDM			
			Thickness: 2,4			
106	O-ring		Diameter: 27.5		1	
			Material type: EPDM			
			Thickness: 2.75			
26	Staybolt				4	pcs
55	Sleeve		Material type: TITAN		1	pcs
76	Nameplate				1	pcs
76a	Rivet				1	pcs
- 80	Chamber stack				1	pcs
3	Top intermediate chamber				1	
- 4	Intermediate chamber cpl.				10	
	Intermediate chamber				1	
45	Seal ring				1	
65	Neck ring retainer				1	
4.a	Intermediate chamber cpl.				3	
26a	Strap cpl.				2	
26b	Hex head screw		Length (mm): 25		2	
			Thread: M8			

Pos	Description	Annotation	Données de classification	Référence	Quantité	Unité
26c	Washer		Internal diameter: 8.4 Outer diameter: 16 Thickness: 1.6		2	
44a	Inlet part cpl.				1	
44b	Inlet part				1	
47a	Bearing ring				2	
- 49	Impeller cpl.				14	
49c	Impeller				1	
51	Shaft cpl.		Diameter: 16 Length (mm): 744		1	
61	Seal driver				1	
64	Spacing pipe		Internal diameter: 17,50 Outer diameter: 21,50 Length (mm): 43,60		10	
64a	Spacing bush				3	
64c	Spacing pipe		Internal diameter: 17,50 Outer diameter: 21,50 Length (mm): 8,50		1	
64d	Spacing bush				3	
67	Lock nut		Thread: M12		1	
67a	Split pin				1	
69	Spacing bush				1	
105	Shaft seal		Material type: AUUE		1	pcs

Disclaimer: The information about the Grundfos pump in this document may be outdated.

Data may be subject to alterations without further notice.

Please contact us to verify the data above is still accurate/up-to-date.

All information is copyright Grundfos.



info@lenntech.com

<https://www.lenntech.com>

tel. +31 152 610 900

fax. +31 152 616 289