

CRT16-2 A-P-A-E-AUUE 3x380-415DV, 50Hz Grundfos pump 96117244



Thank you for your interest in our products. Please contact us for more information, or visit our website

<https://www.lenntech.com/grundfos/CRT16/96117244/CRT-16-2-A-P-A-E-AUUE.html>

info@lenntech.com

tel. +31 152 610 900

fax. +31 152 616 289

Position	Qty.	Description
	1	<p data-bbox="323 163 608 197">CRT 16-2 A-P-A-E-AUUE</p>  <p data-bbox="323 488 842 600">Product No.: On request Vertical, non-self-priming, multistage, in-line, centrifugal pump for installation in pipe systems and mounting on a foundation.</p> <p data-bbox="323 633 949 925">The pump has the following characteristics: - Impellers, intermediate chambers and outer sleeve are made of Titanium. - Pump head cover and base are made of Titanium. - The shaft seal has assembly length according to EN 12756. - Power transmission is via cast iron split coupling. - Pipework connection is via PJE flanges/couplings.</p> <p data-bbox="323 958 694 992">The motor is a 3-phase AC motor.</p> <p data-bbox="323 1025 826 1171">Liquid: Pumped liquid: Water Liquid temperature range: -20 .. 120 °C Liquid temperature during operation: 20 °C Density: 998.2 kg/m³</p> <p data-bbox="323 1205 882 1373">Technical: Rated flow: 16 m³/h Rated head: 21.9 m Primary shaft seal: AUUE Approvals on nameplate: CE, TR Curve tolerance: ISO9906:2012 3B</p> <p data-bbox="323 1406 826 1574">Materials: Pump housing: Titanium ASTM B 265 Impeller: Titanium ASTM B 265 Bush material: NONE</p> <p data-bbox="323 1608 858 1821">Installation: Maximum ambient temperature: 60 °C Max pressure at stated temp: 25 bar / 120 °C 25 bar / -20 °C Flange standard: PJE Pipe connection: 60,3 mm Flange size for motor: FT115</p> <p data-bbox="323 1854 858 2089">Electrical data: Motor type: 90LC IE Efficiency class: IE3 Rated power - P2: 2.2 kW Power (P2) required by pump: 2.2 kW 2.2 kW Mains frequency: 50 Hz Rated voltage: 3 x 380-415D V</p>

Position	Qty.	Description
		<p>Rated current: 4.45 A</p> <p>Starting current: 850-950 %</p> <p>Cos phi - power factor: 0.89-0.87</p> <p>Rated speed: 2890-2910 rpm</p> <p>Efficiency: IE3 85,9%</p> <p>Motor efficiency at full load: 85.9 %</p> <p>Motor efficiency at 3/4 load: 86.8 %</p> <p>Motor efficiency at 1/2 load: 86.0 %</p> <p>Number of poles: 2</p> <p>Enclosure class (IEC 34-5): 55 Dust/Jetting</p> <p>Insulation class (IEC 85): F</p> <p>Others:</p> <p>Minimum efficiency index, MEI : 0.69</p> <p>Net weight: 37 kg</p> <p>Gross weight: 47 kg</p>

On request CRT 16-2 A-P-A-E-AUUE 50 Hz

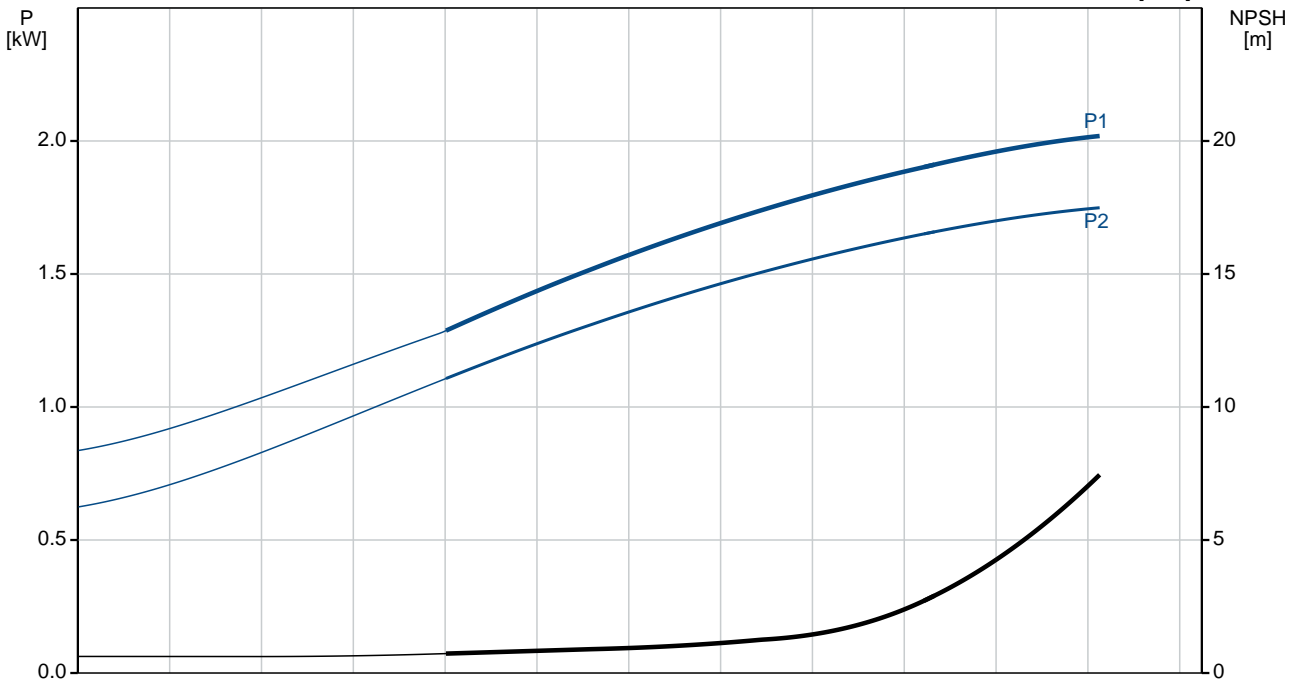
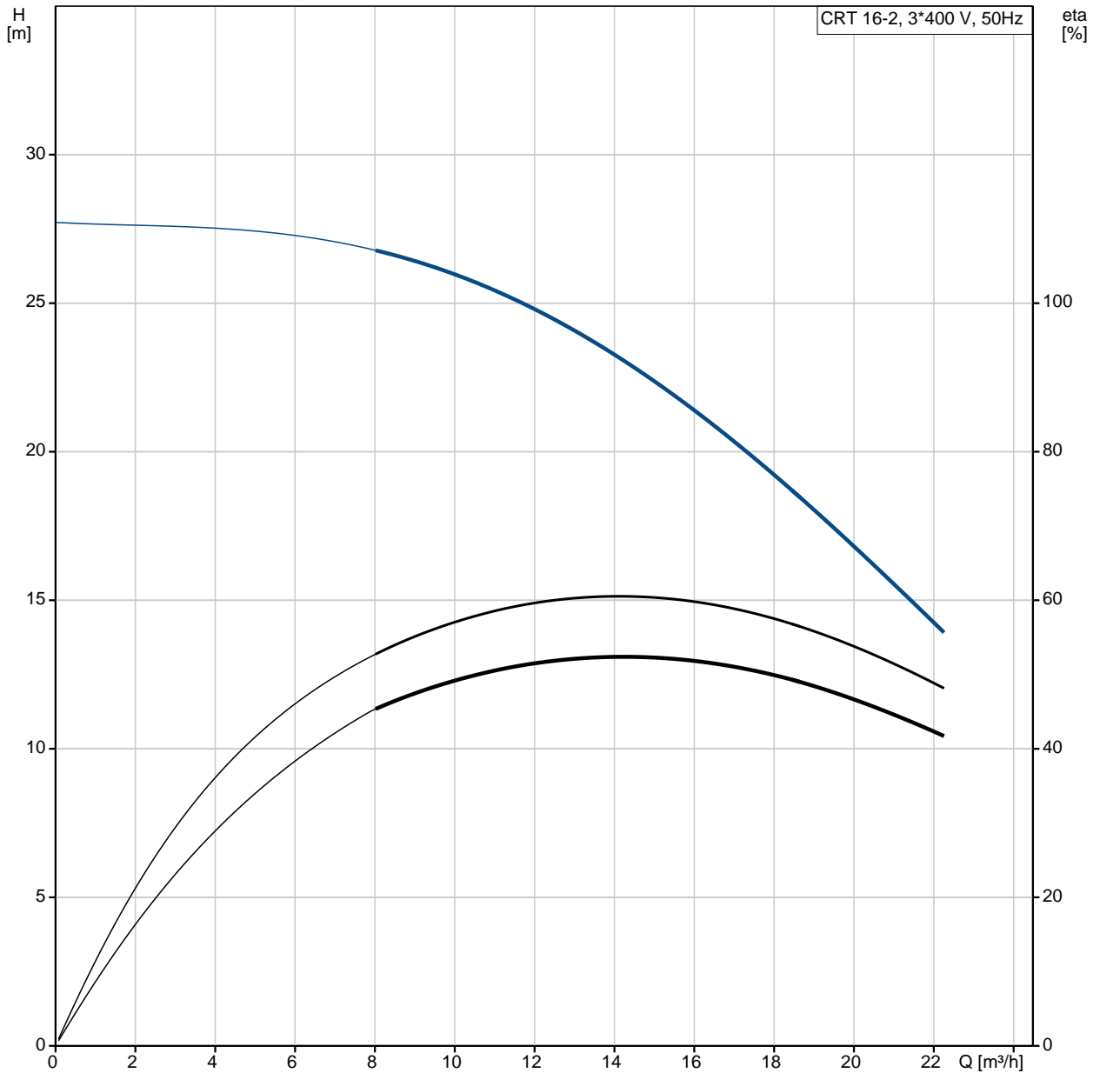

Description	Value
General information:	
Product name:	CRT 16-2 A-P-A-E-AUUE
Product No:	On request
EAN number:	On request
Technical:	
Rated flow:	16 m ³ /h
Rated head:	21.9 m
Head max:	27.3 m
Stages:	3
Impellers:	2
Primary shaft seal:	AUUE
Approvals on nameplate:	CE, TR
Curve tolerance:	ISO9906:2012 3B
Pump version:	A
Model:	A
Materials:	
Pump housing:	Titanium ASTM B 265
Impeller:	Titanium ASTM B 265
Material code:	A
Code for rubber:	E
Bush material:	NONE
Installation:	
Maximum ambient temperature:	60 °C
Max pressure at stated temp:	25 bar / 120 °C 25 bar / -20 °C
Flange standard:	PJE
Pipe connection:	60,3 mm
Flange size for motor:	FT115
Connect code:	P
Liquid:	
Pumped liquid:	Water
Liquid temperature range:	-20 .. 120 °C
Liquid temperature during operation:	20 °C
Density:	998.2 kg/m ³
Electrical data:	
Motor type:	90LC
IE Efficiency class:	IE3
Rated power - P2:	2.2 kW
Power (P2) required by pump:	2.2 kW 2.2 kW
Mains frequency:	50 Hz
Rated voltage:	3 x 380-415D V
Rated current:	4.45 A
Starting current:	850-950 %
Cos phi - power factor:	0.89-0.87
Rated speed:	2890-2910 rpm
Efficiency:	IE3 85,9%
Motor efficiency at full load:	85.9 %
Motor efficiency at 3/4 load:	86.8 %
Motor efficiency at 1/2 load:	86.0 %
Number of poles:	2
Enclosure class (IEC 34-5):	55 Dust/Jetting
Insulation class (IEC 85):	F
Motor protec:	NONE
Motor No:	85U15908
Others:	
Minimum efficiency index, MEI :	0.69
Net weight:	37 kg
Gross weight:	47 kg

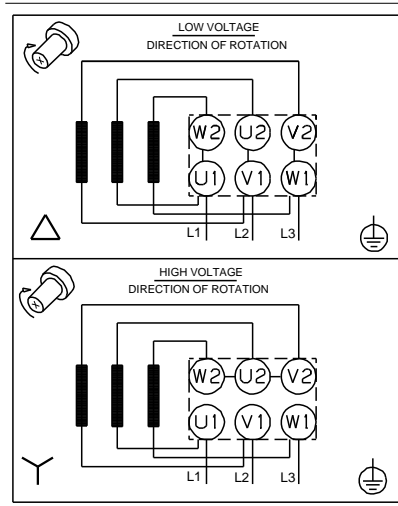
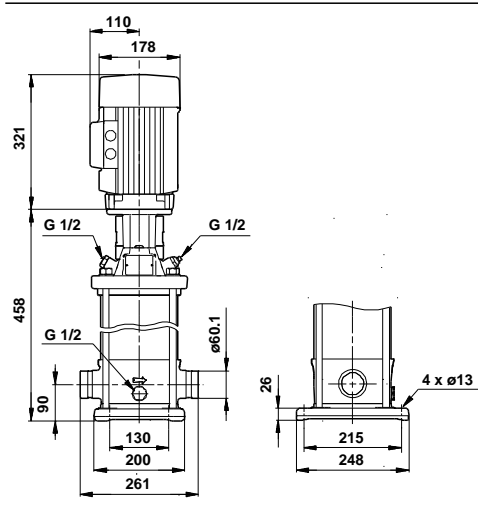
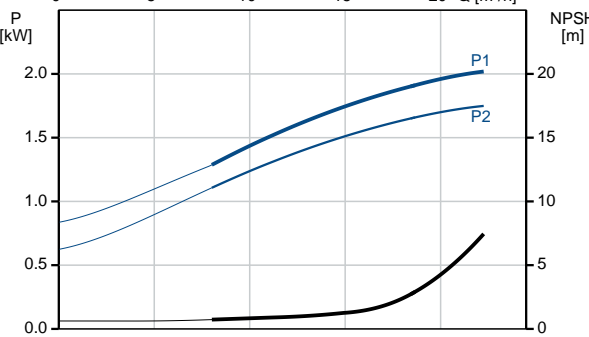
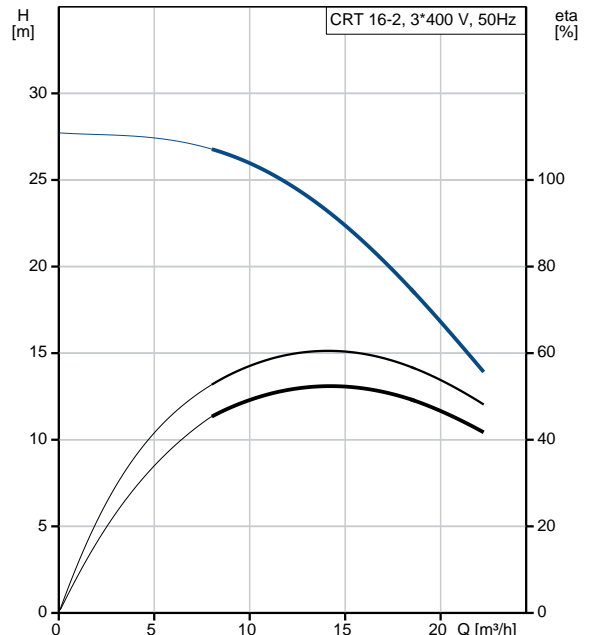

On request CRT 16-2 A-P-A-E-AUUE 50 Hz

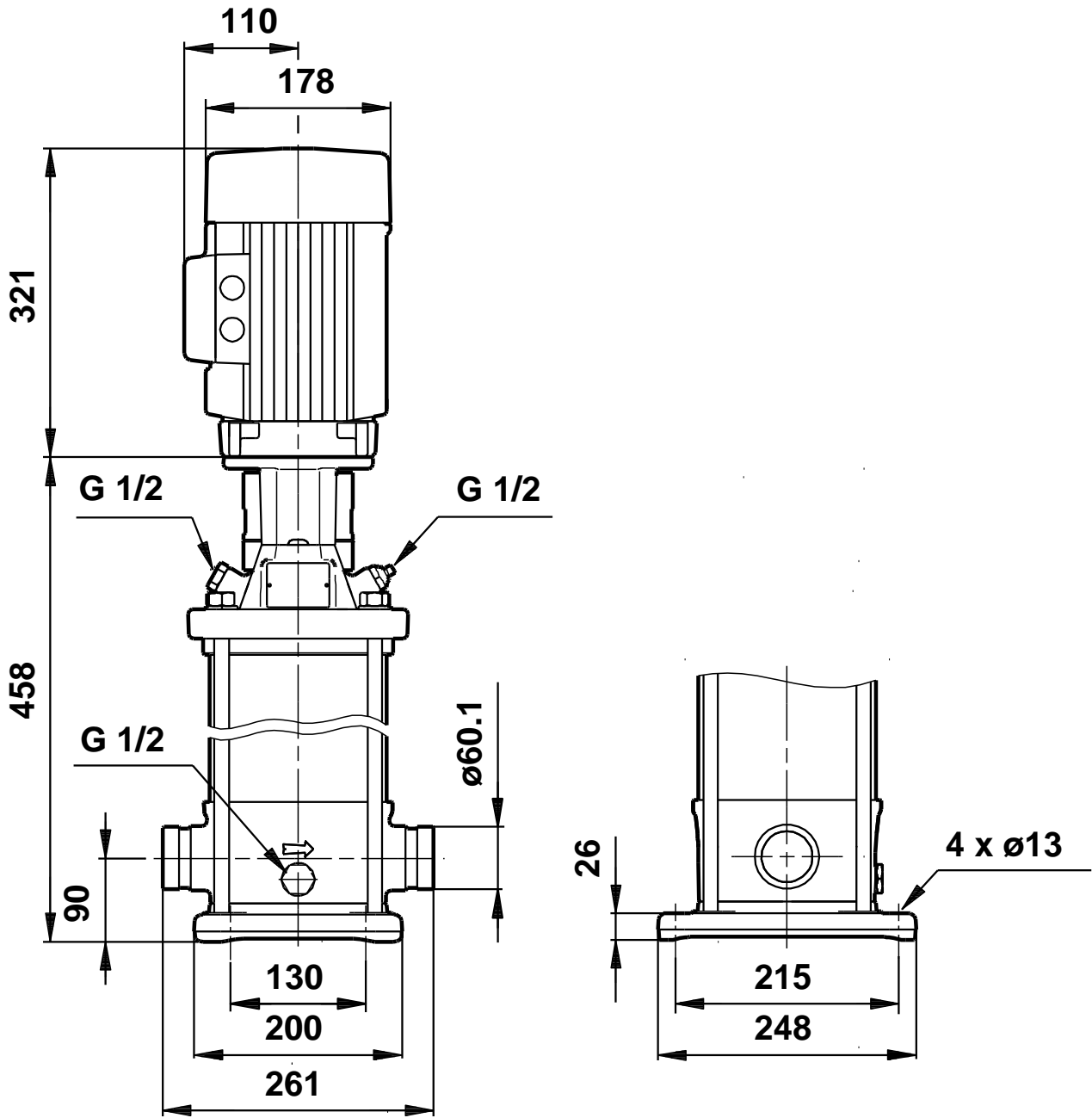

Note! All units are in [mm] unless others are stated.
Disclaimer: This simplified dimensional drawing does not show all details.

Exploded view

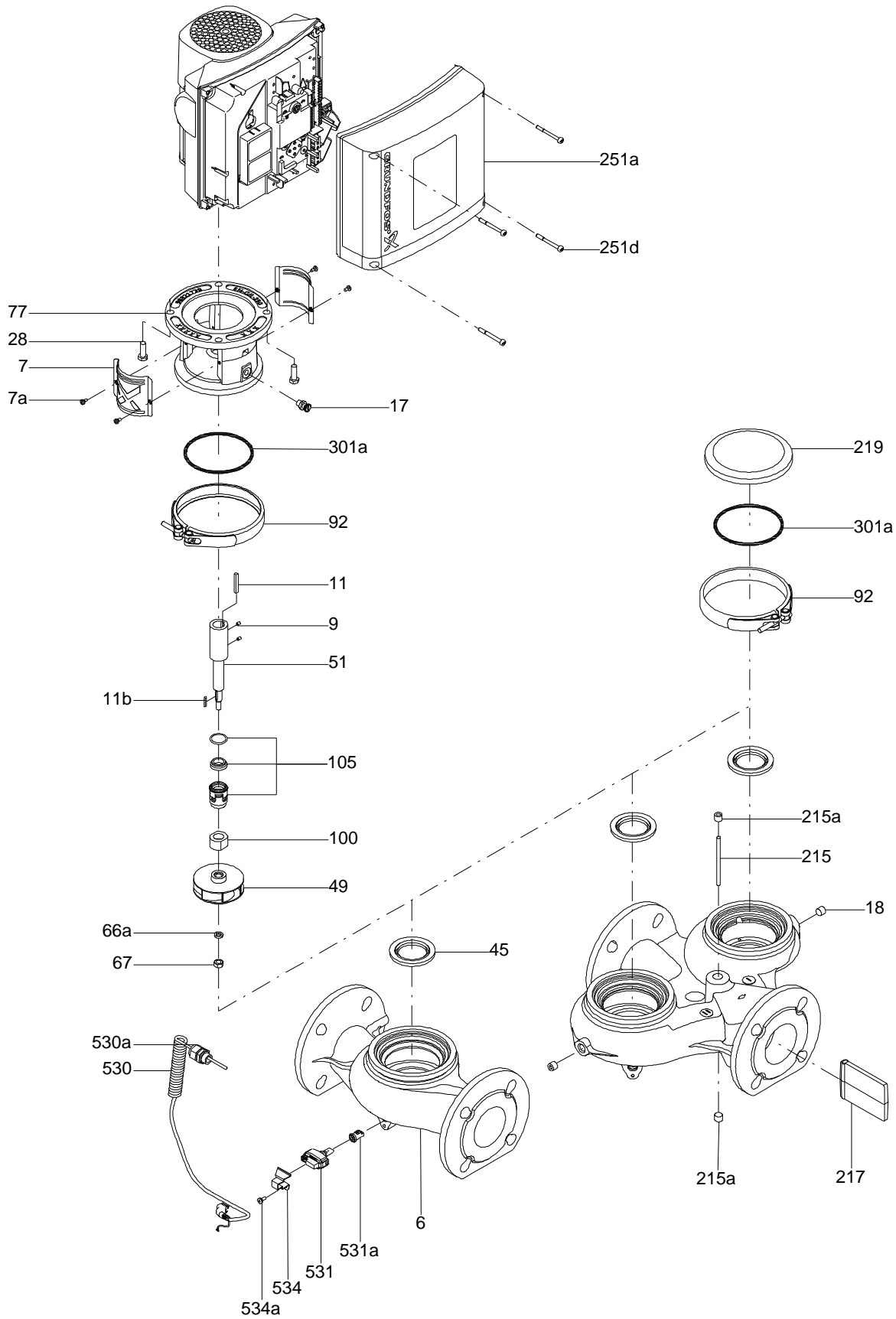

Sectional drawing (TM058200 for TPE2,TPE3)



TM058200

Exploded view (TM057026 for MGE model H/I)

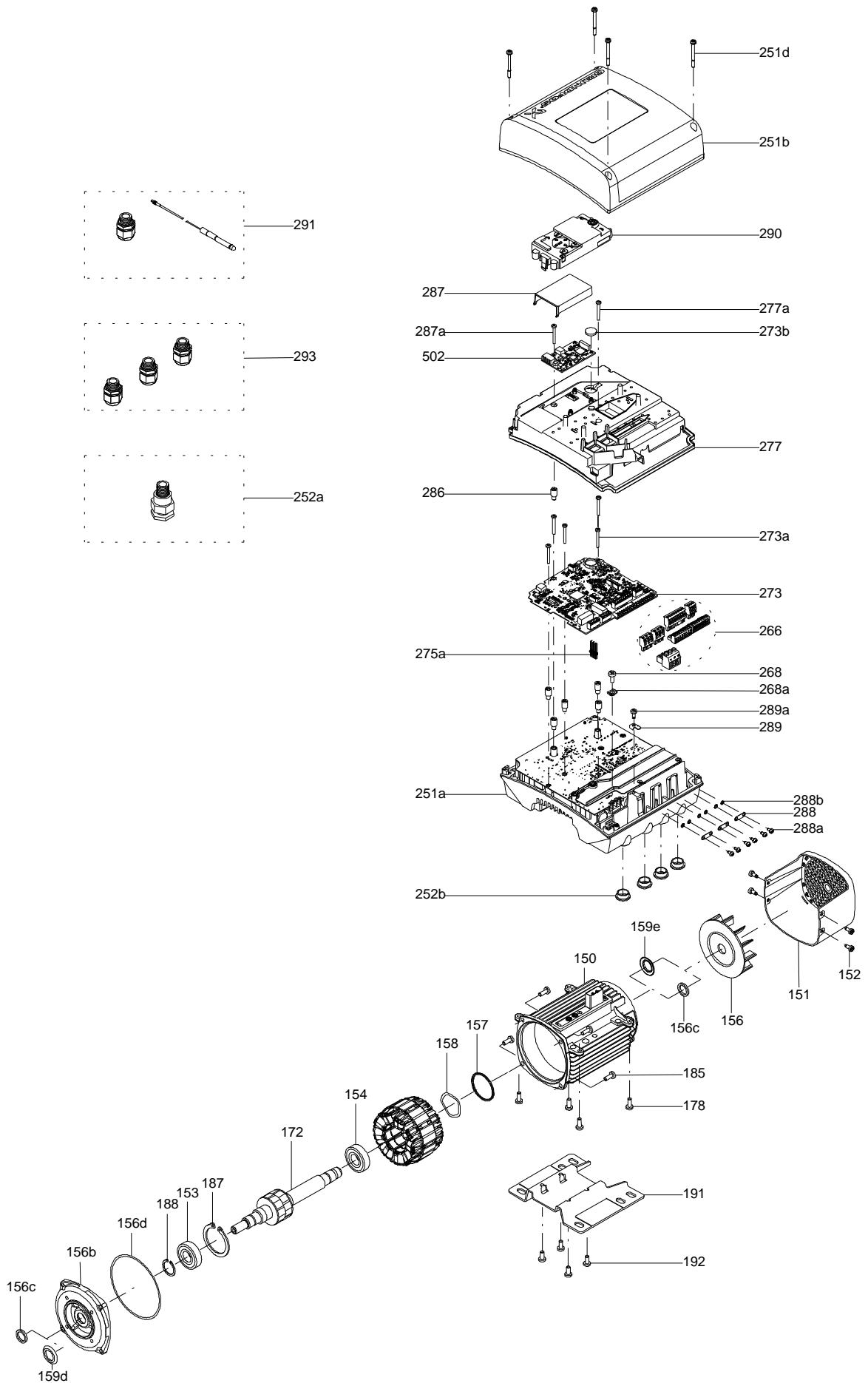

Parts list CRT 16-2, Product No. On request
Valid from 1.1.2011 (1152)

Pos	Description	Annotation	Données de classification	Référence	Quantité	Unité
-	Base cpl.				1	pcs
6	Base				1	
25	Drain plug				1	
56	Base plate				1	
-	Pump head cpl.				1	pcs
2	Pump head				1	
7	Coupling guard				2	
7a	Combi Slot Torx screw				4	
9	Hex socket head cap screw		Designation: DIN 912		4	
			Length (mm): 25			
			Thread: M8			
10	Shaft pin		Diameter: 5		1	
			Length (mm): 26			
10a	Coupling half				2	
18	Air vent screw		Thread: RG 1/2		1	
23	Plug				1	
28	Hex head screw		Length (mm): 20		4	
			Thread: M8			
36	Nut		Thread: M16		4	
37	O-ring				1	
66a	Washer		Designation: DIN 125 A2		4	
			Internal diameter: 17			
			Outer diameter: 30			
			Thickness: 3			
77	Pump head cover				1	
107	Plug				1	
-	Rubber module, EPDM				1	pcs
20	Spring				4	
37	O-ring				2	
38	O-ring		Diameter: 5,3		1	
			Material type: EPDM			
			Thickness: 2,4			
100	O-ring		Diameter: 16,3		2	
			Material type: EPDM			
			Thickness: 2,4			
106	O-ring		Diameter: 27.5		1	
			Material type: EPDM			
			Thickness: 2.75			
26	Staybolt				4	pcs
55	Sleeve		Material type: TITAN		1	pcs
76	Nameplate				1	pcs
76a	Rivet				1	pcs
-	80 Chamber stack				1	pcs
3	Chamber top				1	
-	4 Intermediate chamber cpl.				1	
	Intermediate chamber				1	
45	Seal ring				1	
65	Neck ring retainer				1	
4.a	Intermediate chamber cpl.				1	
26a	Strap cpl.		Thread: M8		2	
26b	Hex head screw		Length (mm): 25		2	
			Thread: M8			
26c	Washer		Internal diameter: 8.4		2	
			Outer diameter: 16			
			Thickness: 1.6			
44a	Inlet part cpl.				1	
44b	Inlet part				1	
47a	Bearing ring				1	
-	49 Impeller cpl.				2	

Pos	Description	Annotation	Données de classification	Référence	Quantité	Unité
49c	Impeller				1	
51	Pump shaft				1	
61	Seal driver				1	
64	Spacing pipe		Internal diameter: 17,50		1	
			Outer diameter: 21,50			
			Length (mm): 29,05			
64	Spacing pipe		Internal diameter: 17,50		1	
			Outer diameter: 21,50			
			Length (mm): 43,60			
64a	Spacing bush				1	
64c	Spacing pipe		Internal diameter: 17,50		1	
			Outer diameter: 21,50			
			Length (mm): 8,50			
64d	Spacing bush				1	
67	Lock nut		Thread: M12		1	
67a	Split pin				1	
105	Shaft seal		Material type: AUUE		1	pcs
+ 2099	Motor				1	pcs

Disclaimer: The information about the Grundfos pump in this document may be outdated.

Data may be subject to alterations without further notice.

Please contact us to verify the data above is still accurate/up-to-date.

All information is copyright Grundfos.



info@lenntech.com

<https://www.lenntech.com>

tel. +31 152 610 900

fax. +31 152 616 289