

## TP 65-130/4-A-F-A-BQQE 400Y 50HZ Grundfos pump 96087443



Thank you for your interest in our products. Please contact us for more information, or visit our website

<https://www.lenntech.com/grundfos/TP000/96087443/TP-65-130-4-A-F-A-BQQE.html>

[info@lenntech.com](mailto:info@lenntech.com)

tel. +31 152 610 900

fax. +31 152 616 289

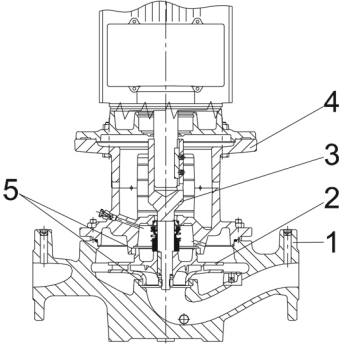
Position	Qty.	Description
	1	<p data-bbox="320 163 614 194"><b>TP 65-130/4 A-F-A-BQQE</b></p>  <p data-bbox="320 486 600 517">Product No.: On request</p> <p data-bbox="320 546 1445 622">Single-stage, close-coupled, volute pump with in-line suction and discharge ports of identical diameter. The pump is of the top-pull-out design, i.e. the power head (motor, pump head and impeller) can be removed for maintenance or service while the pump housing remains in the pipework.</p> <p data-bbox="320 629 1422 683">The pump is fitted with an unbalanced rubber bellows seal. The shaft seal is according to EN 12756. Pipework connection is via PN 16 DIN flanges (EN 1092-2 and ISO 7005-2).</p> <p data-bbox="320 689 951 721">The pump is fitted with a fan-cooled asynchronous motor.</p> <p data-bbox="320 750 639 781"><b>Further product details</b></p> <p data-bbox="320 788 1426 864">The product's minimum efficiency index (MEI) is greater or equal to 0.70. This is by the Commission Regulation (EU) considered as an indicative benchmark for best-performing water pump available on the market as from 1 January 2013.</p> <p data-bbox="320 898 400 929"><b>Pump</b></p> <p data-bbox="320 936 1257 967">Pump housing and pump head are electrocoated to improve the corrosion resistance.</p> <p data-bbox="320 974 584 1005">Electrocoating includes:</p> <ol data-bbox="320 1012 810 1111" style="list-style-type: none"> <li>1) Alkaline-based cleaning.</li> <li>2) Pretreatment with zinc phosphate coating.</li> <li>3) Cathodic electrocoating (epoxy).</li> <li>4) Curing of paint film at 200-250 °C.</li> </ol>  <ol data-bbox="320 1518 608 1666" style="list-style-type: none"> <li>1: Pump housing</li> <li>2: Impeller</li> <li>3: Stub shaft</li> <li>4: Pump head/motor stool</li> <li>5: Wear rings</li> </ol> <p data-bbox="320 1695 1458 1749">The pump housing is provided with a replaceable brass neck ring to reduce the amount of liquid running from the outlet side of the impeller to the inlet side. The impeller is secured to the shaft with a nut.</p> <p data-bbox="320 1809 1441 1886">The pump is fitted with an unbalanced rubber bellows seal with torque transmission across the spring and around the bellows. Due to the bellows, the seal does not wear the shaft, and the axial movement is not prevented by deposits on the shaft.</p> <p data-bbox="320 1899 464 1930">Primary seal:</p> <ul data-bbox="357 1928 919 1986" style="list-style-type: none"> <li>• Rotating seal ring material: silicon carbide (SiC)</li> <li>• Stationary seat material: silicon carbide (SiC)</li> </ul> <p data-bbox="320 1989 1426 2042">This material pairing is used where higher corrosion resistance is required. The high hardness of this material pairing offers good resistance against abrasive particles.</p> <p data-bbox="320 2045 986 2076">Secondary seal material: EPDM (ethylene-propylene rubber)</p> <p data-bbox="320 2078 1219 2110">EPDM has excellent resistance to hot water. EPDM is not suitable for mineral oils.</p>

Position	Qty.	Description
		<p>A circulation of liquid through the duct of the air vent screw ensures lubrication and cooling of the shaft seal.</p> <p>The flanges have tappings for mounting of pressure gauges.</p> <p>The motor stool forms connection between the pump housing and the motor, and is equipped with a manual air vent screw for venting of the pump housing and the shaft seal chamber. The sealing between motor stool and pump housing is an O-ring.</p> <p>The central part of the motor stool is provided with guards for protection against the shaft and coupling. The pump shaft is fastened directly on the motor shaft with key and set screws.</p> <p><b>Motor</b></p> <p>The motor is a totally enclosed, fan-cooled motor with principal dimensions to IEC and DIN standards. Electrical tolerances comply with IEC 60034.</p> <p>The motor is flange-mounted with free-hole flange (FF). Motor-mounting designation in accordance with IEC 60034-7: IM B 5, IM V 1 (Code I) / IM 3001, IM 3011 (Code II).</p> <p>The motor efficiency is classified as IE3 in accordance with IEC 60034-30-1. The motor does not incorporate motor protection and must be connected to a motor-protective circuit breaker which can be manually reset. The motor-protective circuit breaker must be set according to the rated current of the motor (I1/1).</p> <p>The motor can be connected to a variable speed drive for adjustment of pump performance to any duty point. Grundfos CUE offers a range of variable speed drives. Please find more information in Grundfos Product Center.</p> <p><b>Technical data</b></p> <p><b>Liquid:</b> Pumped liquid: Water Liquid temperature range: -25 .. 120 °C Liquid temperature during operation: 20 °C Density: 998.2 kg/m<sup>3</sup></p> <p><b>Technical:</b> Rated flow: 29.8 m<sup>3</sup>/h Rated head: 10.6 m Actual impeller diameter: 190 mm Primary shaft seal: BQQE Curve tolerance: ISO9906:2012 3B</p> <p><b>Materials:</b> Pump housing: Cast iron EN-JL1040 ASTM A48-40 B Impeller: Cast iron EN-JL1030 ASTM A48-30 B</p> <p><b>Installation:</b> Range of ambient temperature: -30 .. 60 °C Maximum operating pressure: 16 bar Flange standard: DIN Pipe connection: DN 65 Pump inlet: DN 65 Pump outlet: DN 65 Pressure rating: PN 16 (@): 475 mm Flange size for motor: FF165</p> <p><b>Electrical data:</b> Motor type: 90LC IE Efficiency class: IE3 Rated power - P2: 1.5 kW</p>

Position	Qty.	Description
		Power (P2) required by pump: 1.5 kW Mains frequency: 50 Hz Rated voltage: 3 x 220-240D/380-415Y V Rated current: 6,15-6,30/3,55-3,65 A Starting current: 730-790 % Cos phi - power factor: 0.75-0.68 Rated speed: 1450-1460 rpm Efficiency: IE3 85,3% Motor efficiency at full load: 85.3 % Motor efficiency at 3/4 load: 85.8 % Motor efficiency at 1/2 load: 84.2 % Number of poles: 4 Enclosure class (IEC 34-5): 55 Dust/Jetting Insulation class (IEC 85): F  <b>Others:</b> Minimum efficiency index, MEI : 0.70 ErP status: EuP Standalone/Prod. Net weight: 71 kg Gross weight: 85 kg Shipping volume: 0.39 m <sup>3</sup> Danish VVS No.: 381714130 Norwegian NRF no.: 9043569

# On request TP 65-130/4 A-F-A-BQQE 50 Hz

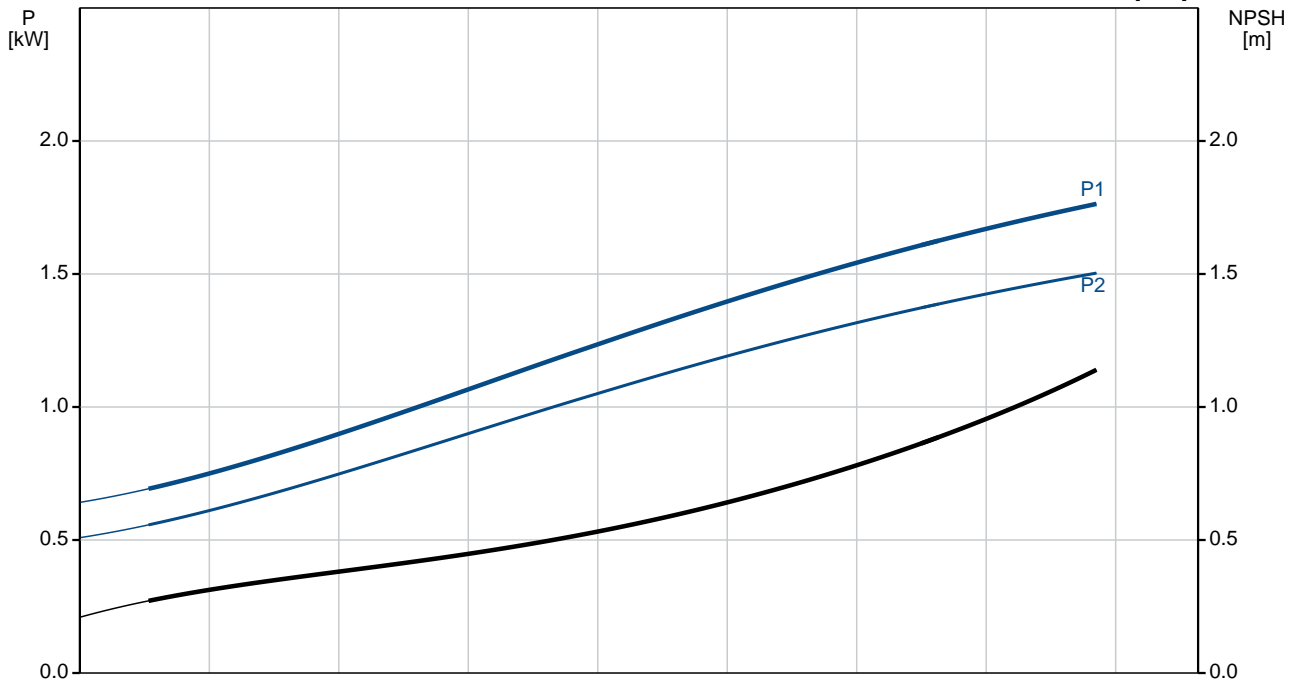
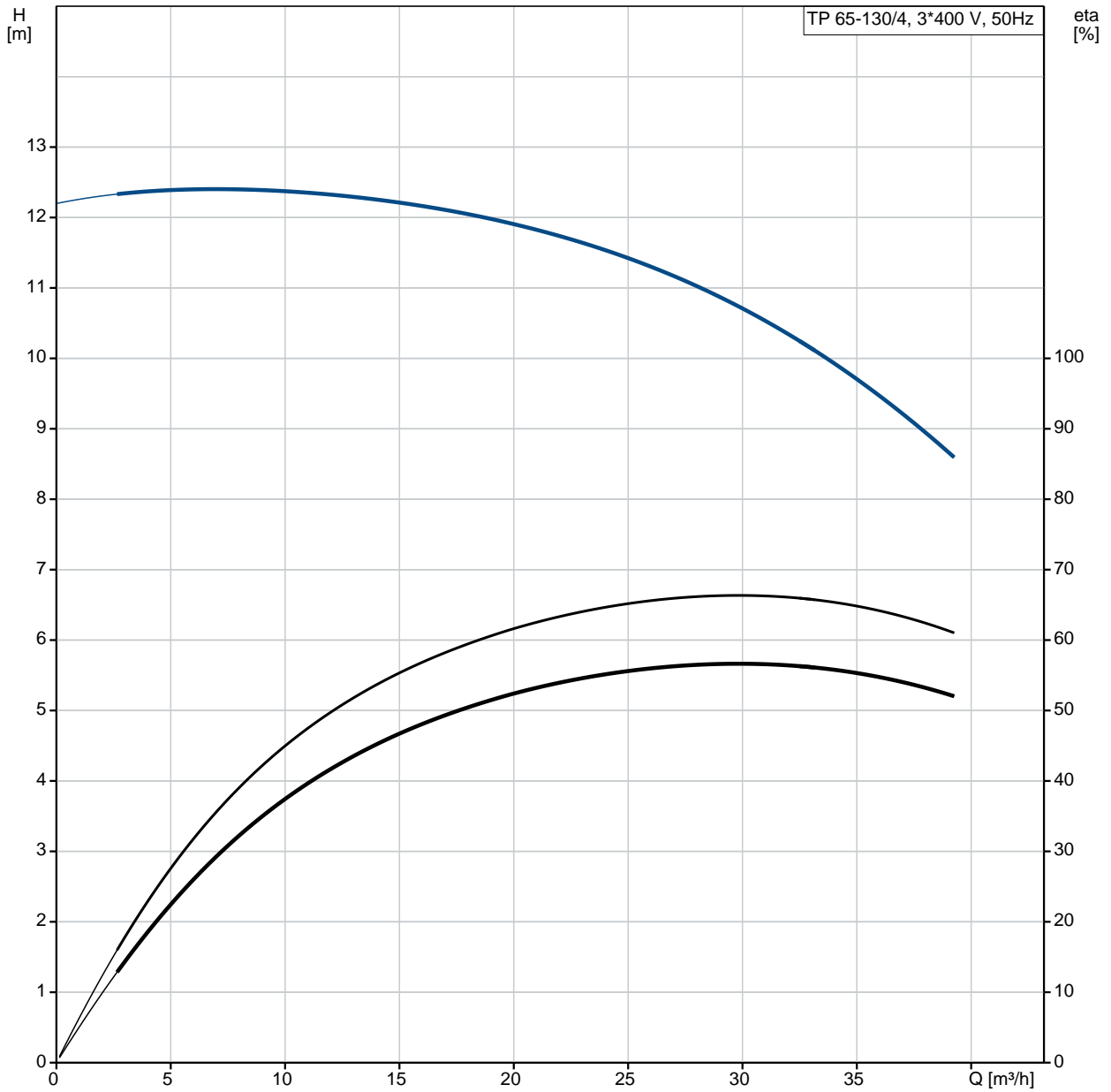

Description	Value
<b>General information:</b>	
Product name:	TP 65-130/4 A-F-A-BQQE
Product No:	On request
EAN number:	On request
<b>Technical:</b>	
Rated flow:	29.8 m <sup>3</sup> /h
Rated head:	10.6 m
Head max:	130 dm
Actual impeller diameter:	190 mm
Primary shaft seal:	BQQE
Curve tolerance:	ISO9906:2012 3B
Pump version:	A
Model:	A
<b>Materials:</b>	
Pump housing:	Cast iron EN-JL1040 ASTM A48-40 B
Impeller:	Cast iron EN-JL1030 ASTM A48-30 B
Material code:	A
<b>Installation:</b>	
Range of ambient temperature:	-30 .. 60 °C
Maximum operating pressure:	16 bar
Flange standard:	DIN
Pipe connection:	DN 65
Pump inlet:	DN 65
Pump outlet:	DN 65
Pressure rating:	PN 16
(@)	475 mm
Flange size for motor:	FF165
Connect code:	F
<b>Liquid:</b>	
Pumped liquid:	Water
Liquid temperature range:	-25 .. 120 °C
Liquid temperature during operation:	20 °C
Density:	998.2 kg/m <sup>3</sup>
<b>Electrical data:</b>	
Motor type:	90LC
IE Efficiency class:	IE3
Rated power - P2:	1.5 kW
Power (P2) required by pump:	1.5 kW
Mains frequency:	50 Hz
Rated voltage:	3 x 220-240D/380-415Y V
Rated current:	6,15-6,30/3,55-3,65 A
Starting current:	730-790 %
Cos phi - power factor:	0.75-0.68
Rated speed:	1450-1460 rpm
Efficiency:	IE3 85,3%
Motor efficiency at full load:	85.3 %
Motor efficiency at 3/4 load:	85.8 %
Motor efficiency at 1/2 load:	84.2 %
Number of poles:	4
Enclosure class (IEC 34-5):	55 Dust/Jetting
Insulation class (IEC 85):	F
Motor protec:	NONE
Motor No:	87220319
<b>Others:</b>	
Minimum efficiency index, MEI :	0.70
ErP status:	EuP Standalone/Prod.
Net weight:	71 kg
Gross weight:	85 kg
Shipping volume:	0.39 m <sup>3</sup>
Danish VVS No.:	381714130

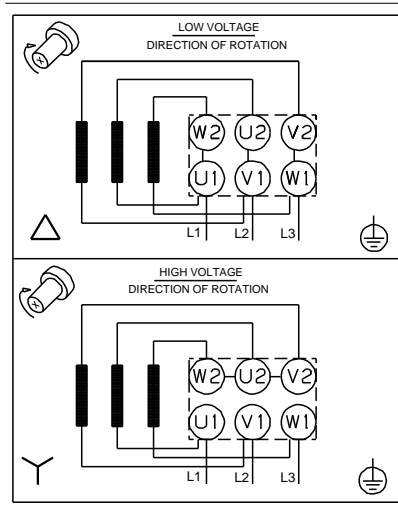
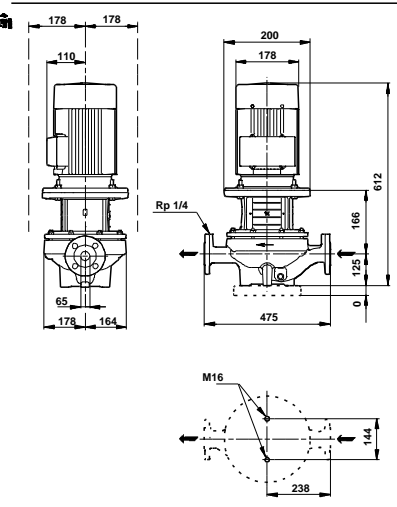
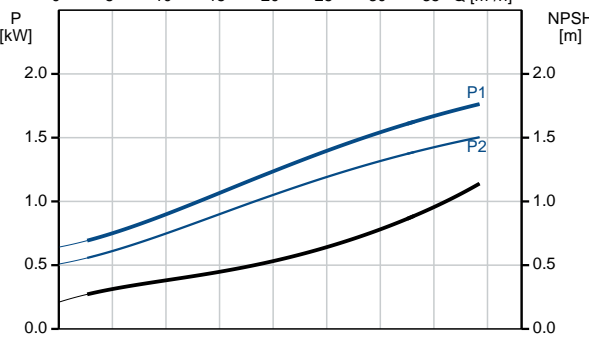
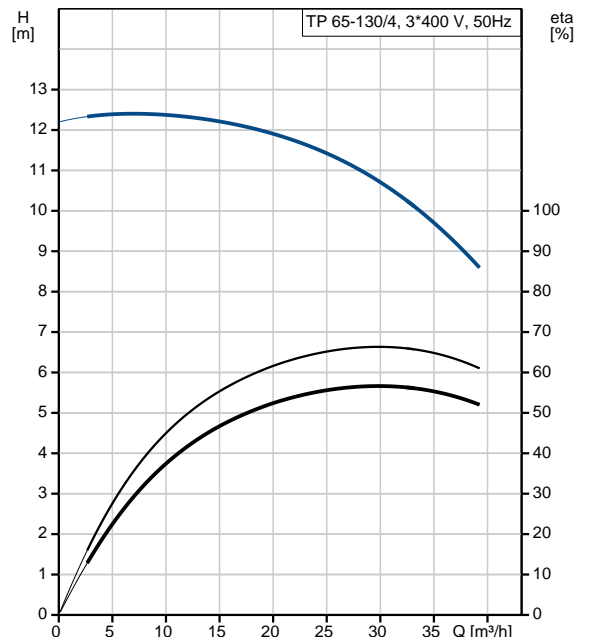

Description	Value
Norwegian NRF no.:	9043569

# On request TP 65-130/4 A-F-A-BQQE 50 Hz

TP65-130/4 + 90LC 1.5 kW 3\*400 V, 50 Hz

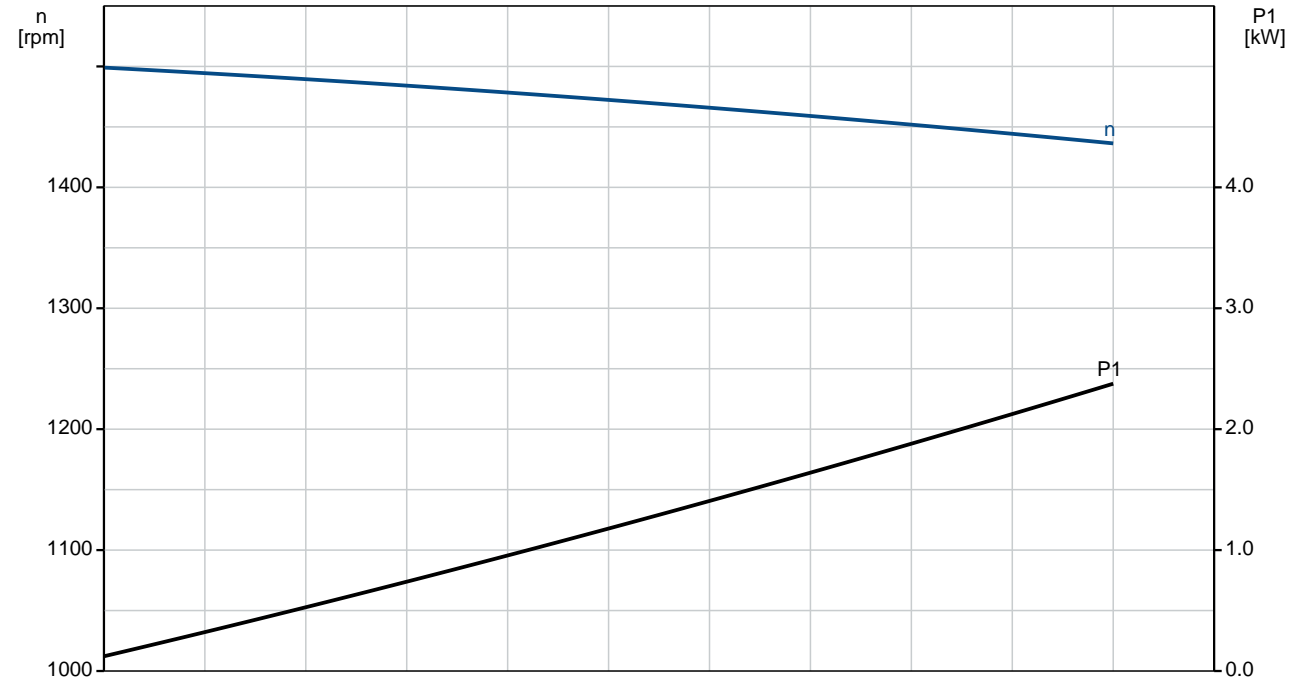
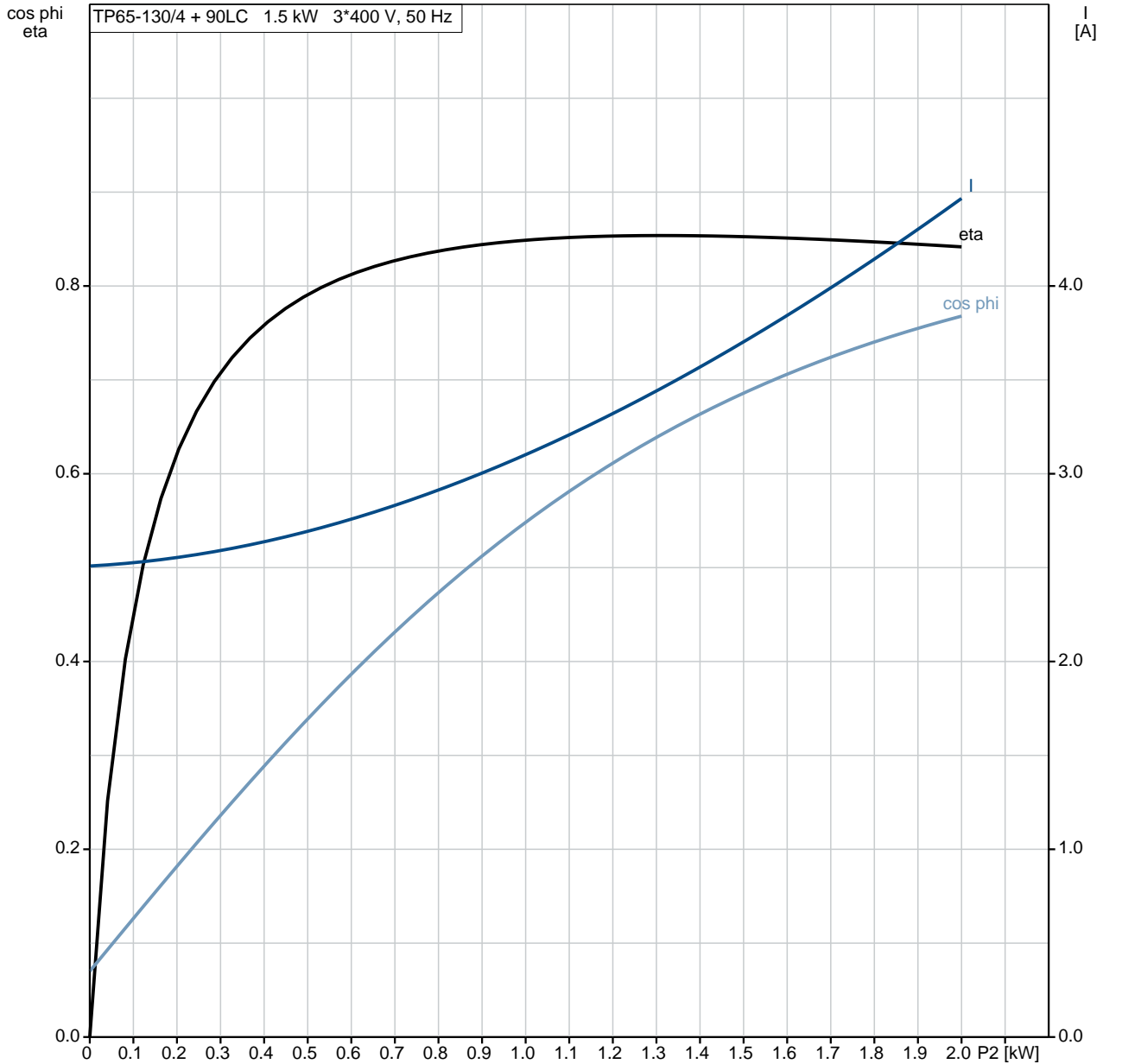



**On request TP 65-130/4 A-F-A-BQQE 50 Hz**

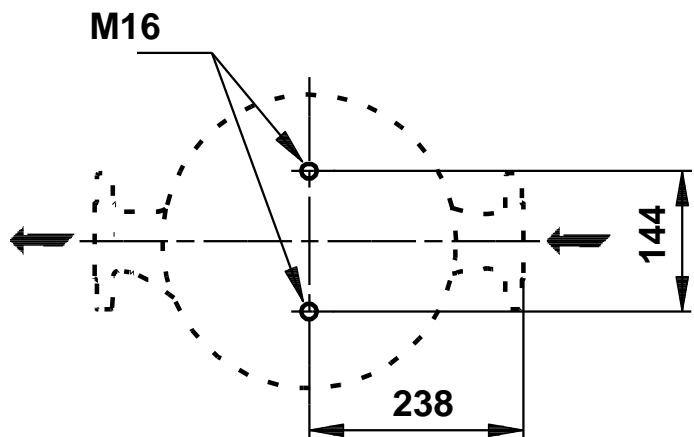
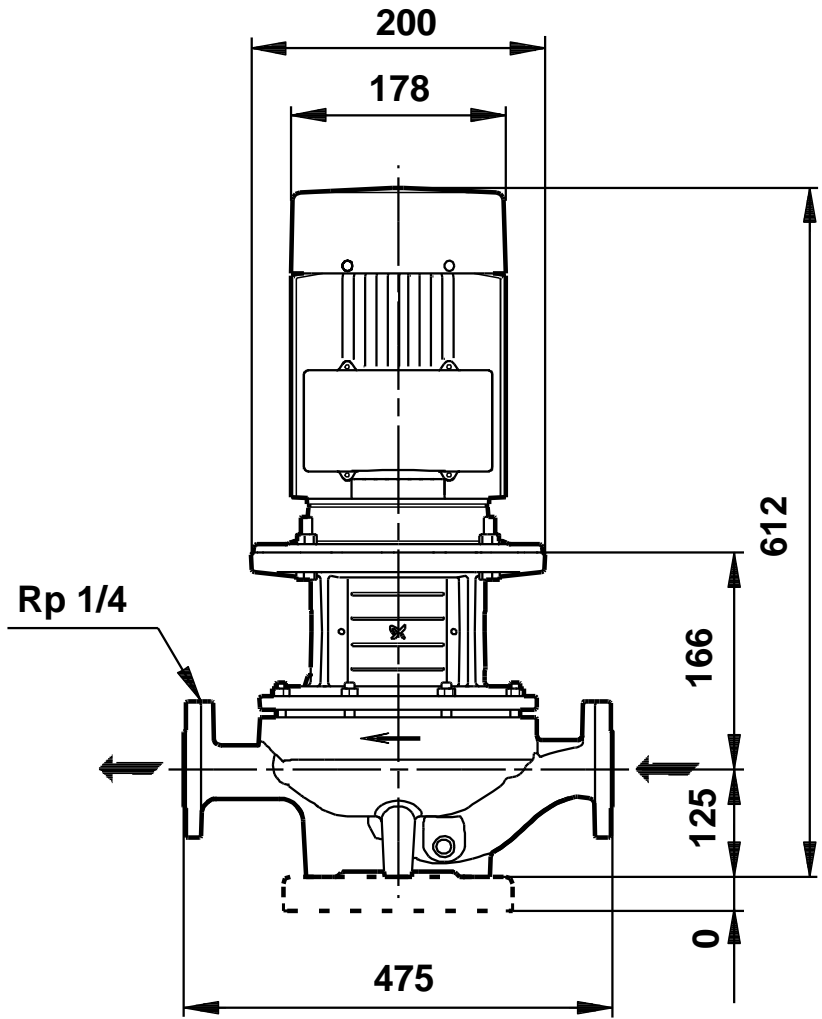
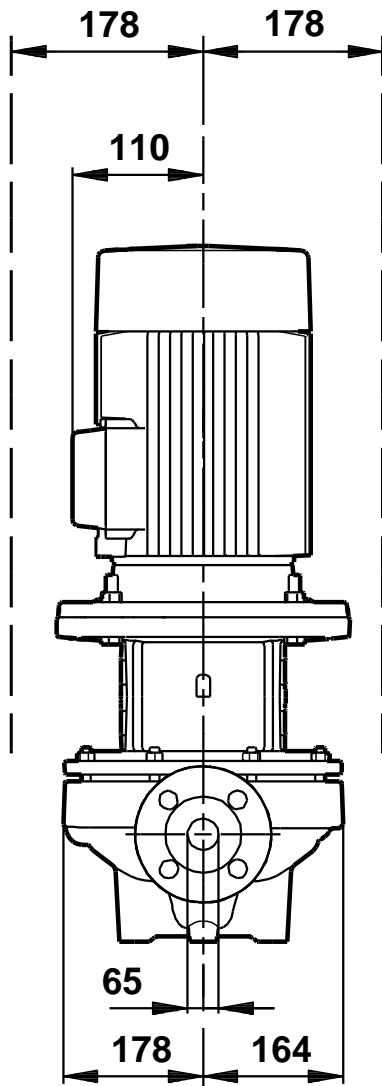

Note! All units are in [mm] unless others are stated.  
Disclaimer: This simplified dimensional drawing does not show all details.

**Exploded view**

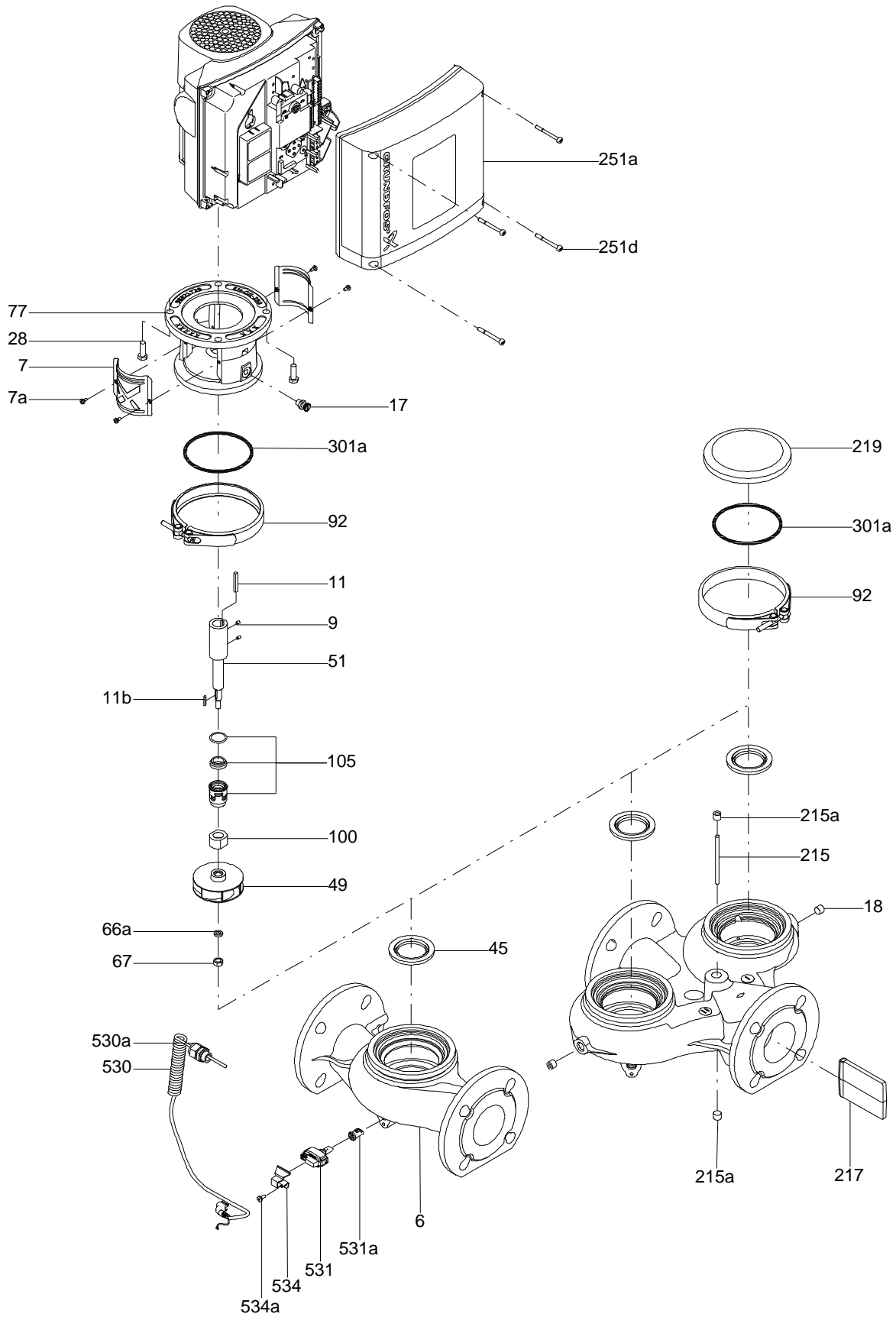

Sectional drawing (TM058200 for TPE2,TPE3)



TM058200

**Exploded view ( TM057026 for MGE model H/I )**

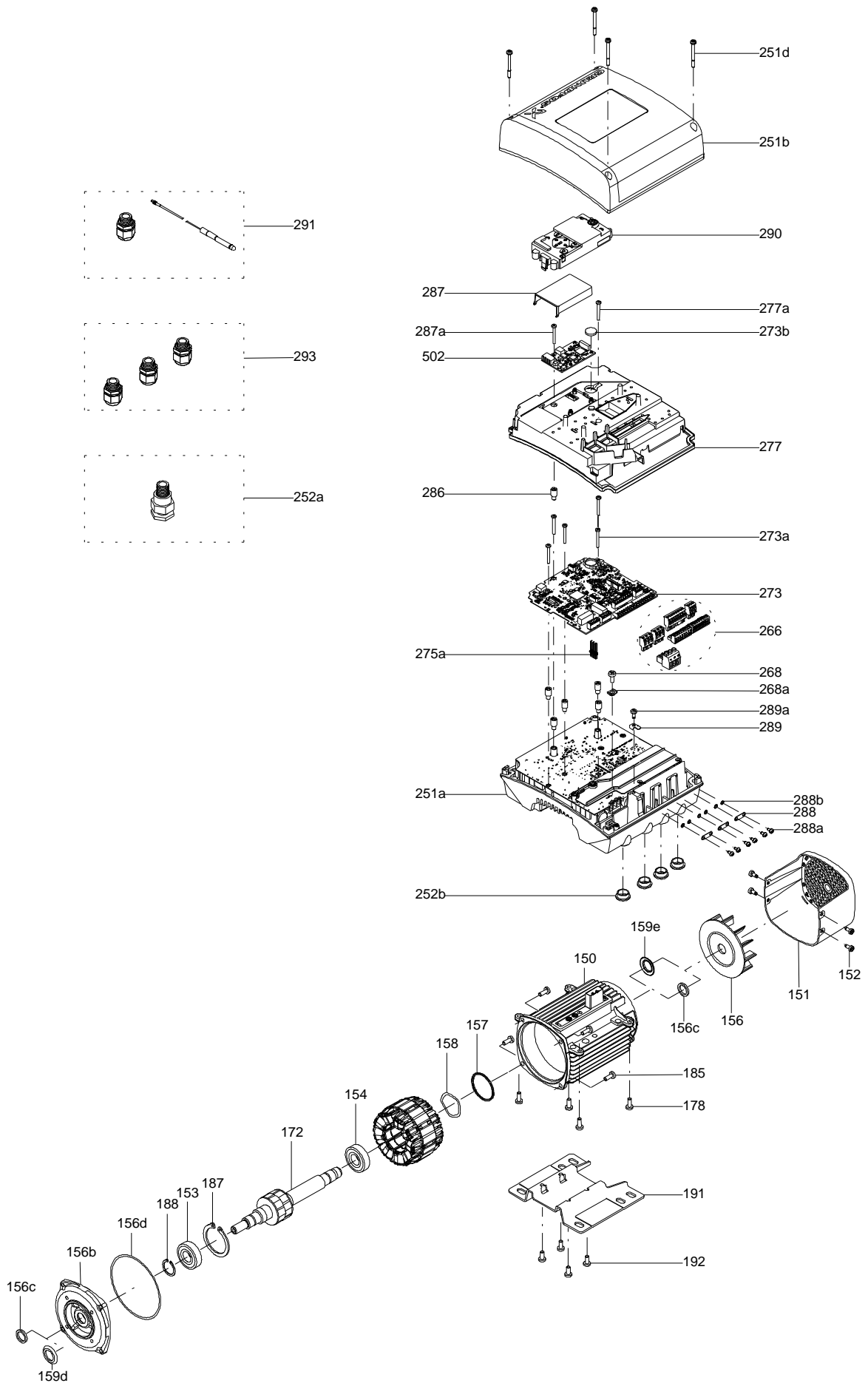

**Parts list TP 65-130/4, Product No. On request**  
**Valid from 1.1.2011 (1152)**

Pos	Description	Annotation	Données de classification	Référence	Quantité	Unité
+	Motor				1	pcs
-	Nut				1	pcs
66	Washer				1	
66a	Spring lock washer				1	
67	Nut		Thread: M14		1	
-	Motor stool cpl.				1	pcs
2	Motor stool				1	
7	Coupling guard				2	
7a	Pan head screw				4	
9	Hex socket head cap screw		Length (mm): 30 Thread: M10		4	
-	Pump housing cpl.				1	pcs
6	Pump housing				1	
36	Nut		Thread: M10		10	
-	Shaft seal cpl.				1	pcs
72a	O-ring		Diameter: 253,6 Material type: EPDM Thickness: 3,53		1	
105	Shaft seal				1	
-	Stub shaft				1	pcs
9	Socket set screw		Length (mm): 6 Thread: M8		2	
11	Parallel key		Dimension: 6X6X35		1	
51	Pump shaft				1	
19	Plug				2	pcs
49	Impeller		Outer diameter: 190		1	pcs

*Disclaimer: The information about the Grundfos pump in this document may be outdated.*

*Data may be subject to alterations without further notice.*

*Please contact us to verify the data above is still accurate/up-to-date.*

All information is copyright Grundfos.



[info@lenntech.com](mailto:info@lenntech.com)

<https://www.lenntech.com>

tel. +31 152 610 900

fax. +31 152 616 289