

SP3A- 9NE 2.2kW 1x220V 50Hz Grundfos pump 10222109



Thank you for your interest in our products. Please contact us for more information, or visit our website

<https://www.lenntech.com/grundfos/SPNE03/10222109/SP-3A-9NE.html>

info@lenntech.com

tel. +31 152 610 900

fax. +31 152 616 289

Position	Qty.	Description
	1	<p data-bbox="320 159 448 185">SP 3A-9NE</p>  <p data-bbox="711 593 1193 616" style="text-align: center;">Note! Product picture may differ from actual product</p> <p data-bbox="320 624 1292 712">Product No.: On request Multi-stage submersible pump designed for pumping of chemically polluted groundwater. The pump is made entirely of Stainless steel DIN W.-Nr. DIN W.-Nr. 1.4401.</p> <p data-bbox="320 741 1420 795">The motor is a 1-phase motor with sand shield, mechanical shaft seal, liquid-lubricated bearings and pressure equalizing diaphragm.</p> <p data-bbox="320 831 1434 857">Pumpset delivered without motor cable. Motor cable to be ordered separately – EPR, Teflon or XLPE.</p> <p data-bbox="320 891 817 1037">Liquid: Pumped liquid: Water Max liquid t at 0.15 m/sec: 40 °C Liquid temperature during operation: 20 °C Density: 998.2 kg/m³</p> <p data-bbox="320 1070 882 1216">Technical: Rated flow: 3 m³/h Rated head: 42 m Shaft seal for motor: SIC/SIC Curve tolerance: ISO9906:2012 3B</p> <p data-bbox="320 1249 887 1541">Materials: Pump: Stainless steel DIN W.-Nr. 1.4401 AISI 316 Impeller: Stainless steel DIN W.-Nr. 1.4401 AISI 316 Motor: Stainless steel DIN W.-Nr. 1.4539 AISI 904 L</p> <p data-bbox="320 1574 778 1662">Installation: Pump outlet: Rp 1 1/4 Motor diameter: 4 inch</p> <p data-bbox="320 1695 853 2076">Electrical data: Motor type: MS4000 Type of motor: CSCR Rated power - P2: 2.2 kW Mains frequency: 50 Hz Rated voltage: 1 x 220-230 V Rated current: 14.6-14.0 A Cos phi - power factor: 0.96-0.96 Rated speed: 2850-2870 rpm Start. method: direct-on-line Enclosure class (IEC 34-5): IP68 Insulation class (IEC 85): F Built-in temp. transmitter: no</p>

Position	Qty.	Description
		<p>Others: Minimum efficiency index, MEI : 0.70 Net weight: 18.2 kg</p>

On request SP 3A-9NE 50 Hz

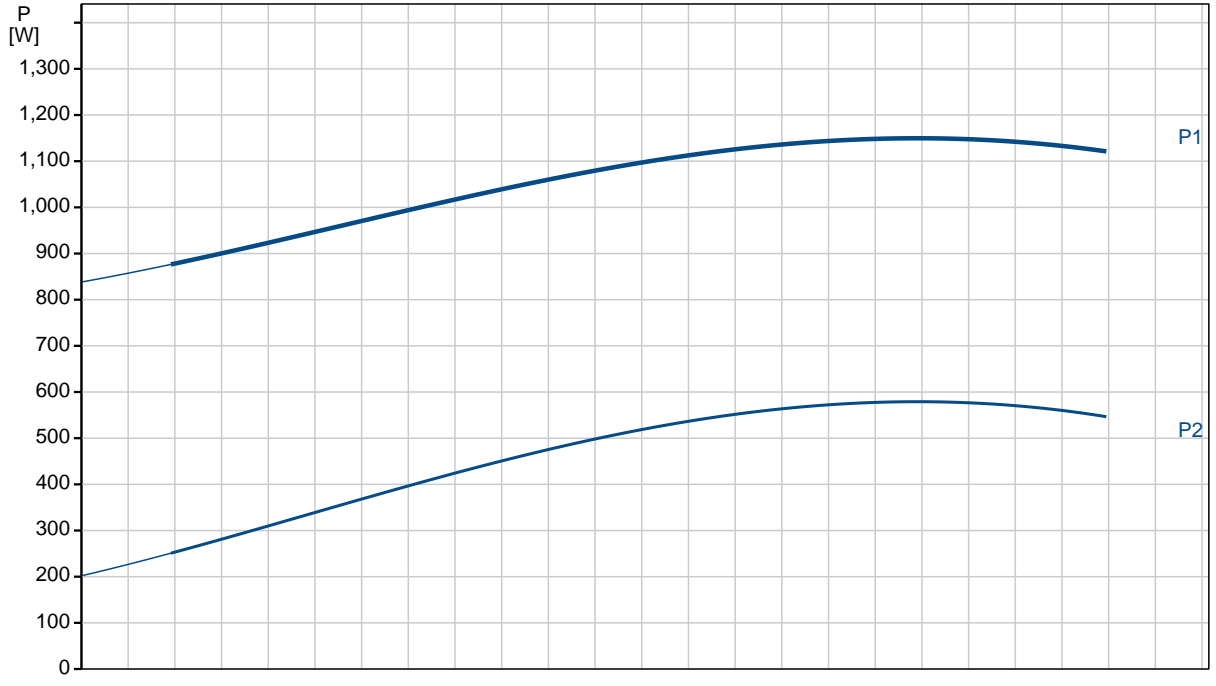
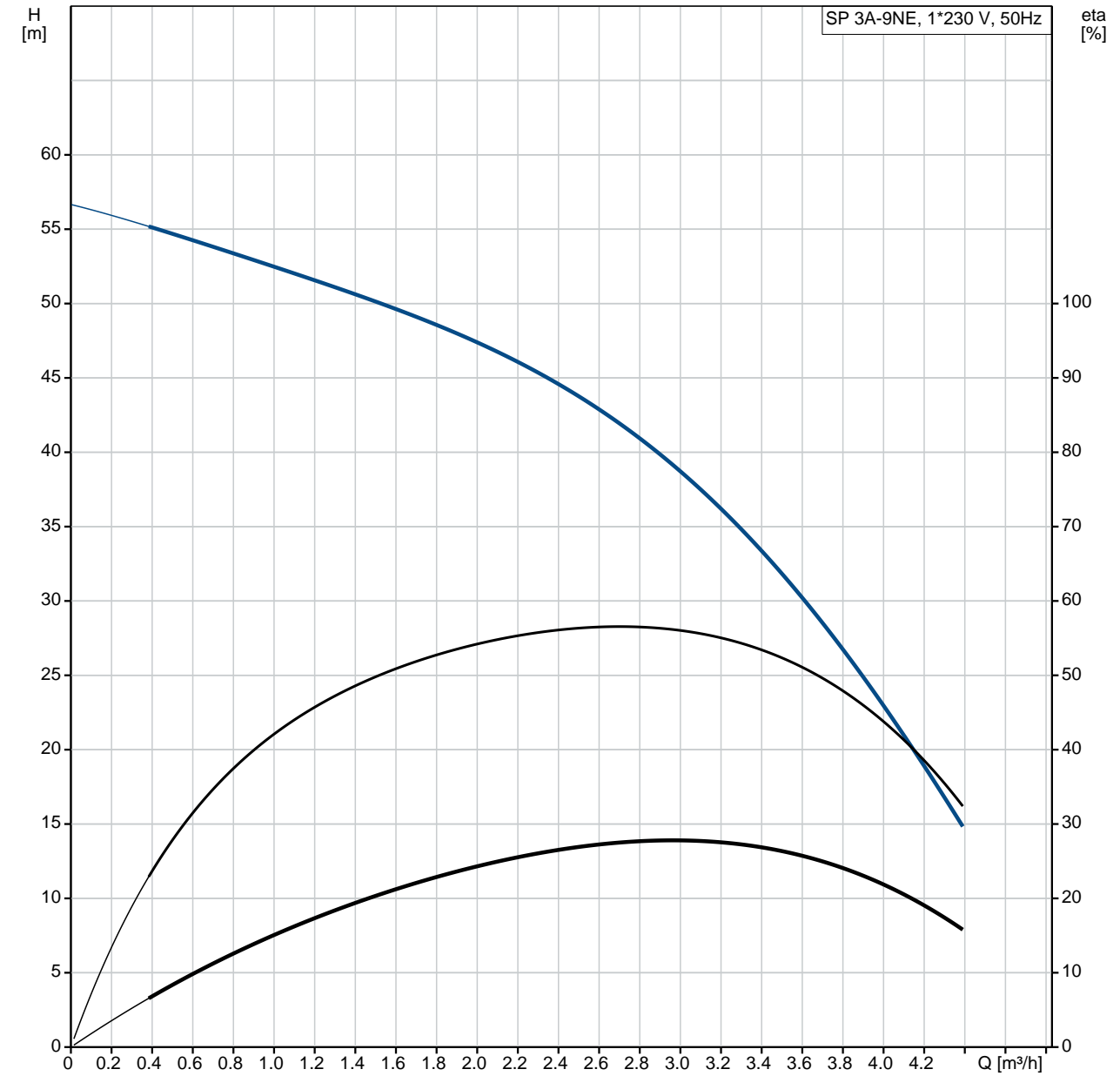

Description	Value
General information:	
Product name:	SP 3A-9NE
Product No:	On request
EAN number:	On request
Technical:	
Rated flow:	3 m ³ /h
Rated head:	42 m
Stages:	9
Shaft seal for motor:	SIC/SIC
Curve tolerance:	ISO9906:2012 3B
Pump No:	10220009
Model:	A
Valve:	no non-return valve
Materials:	
Pump:	Stainless steel DIN W.-Nr. 1.4401 AISI 316
Impeller:	Stainless steel DIN W.-Nr. 1.4401 AISI 316
Motor:	Stainless steel DIN W.-Nr. 1.4539 AISI 904 L
Installation:	
Pump outlet:	Rp 1 1/4
Motor diameter:	4 inch
Liquid:	
Pumped liquid:	Water
Max liquid t at 0.15 m/sec:	40 °C
Liquid temperature during operation:	20 °C
Density:	998.2 kg/m ³
Electrical data:	
Motor type:	MS4000
Type of motor:	CSCR
Rated power - P2:	2.2 kW
Mains frequency:	50 Hz
Rated voltage:	1 x 220-230 V
Rated current:	14.6-14.0 A
Cos phi - power factor:	0.96-0.96
Rated speed:	2850-2870 rpm
Start. method:	direct-on-line
Enclosure class (IEC 34-5):	IP68
Insulation class (IEC 85):	F
Motor protec:	NONE
Thermal protec:	external
Built-in temp. transmitter:	no
Motor No:	79214407
Others:	
Minimum efficiency index, MEI :	0.70
Net weight:	18.2 kg

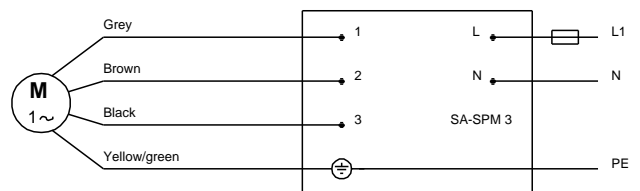
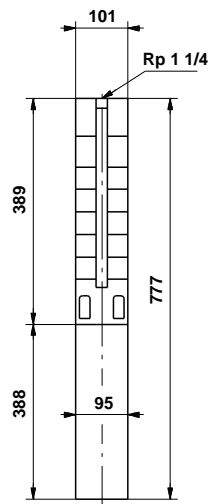
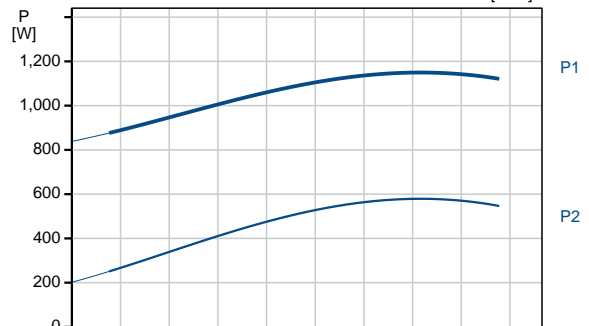
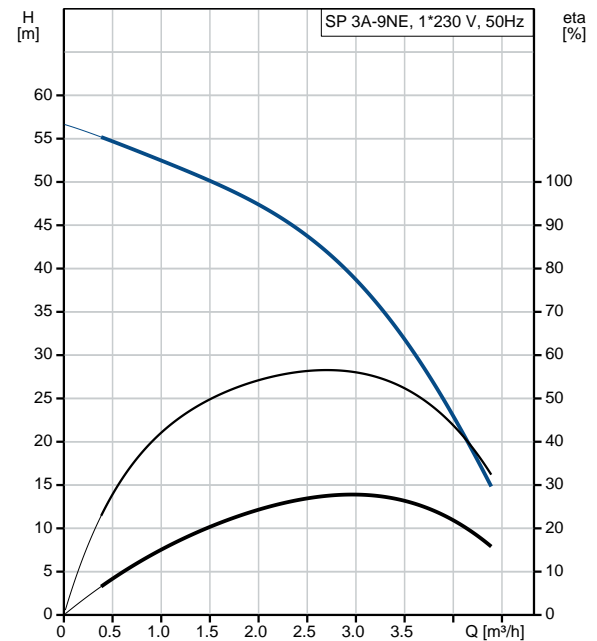

On request SP 3A-9NE 50 Hz

SP3A-9NE + MS4000 2.2 kW 1*230 V, 50 Hz

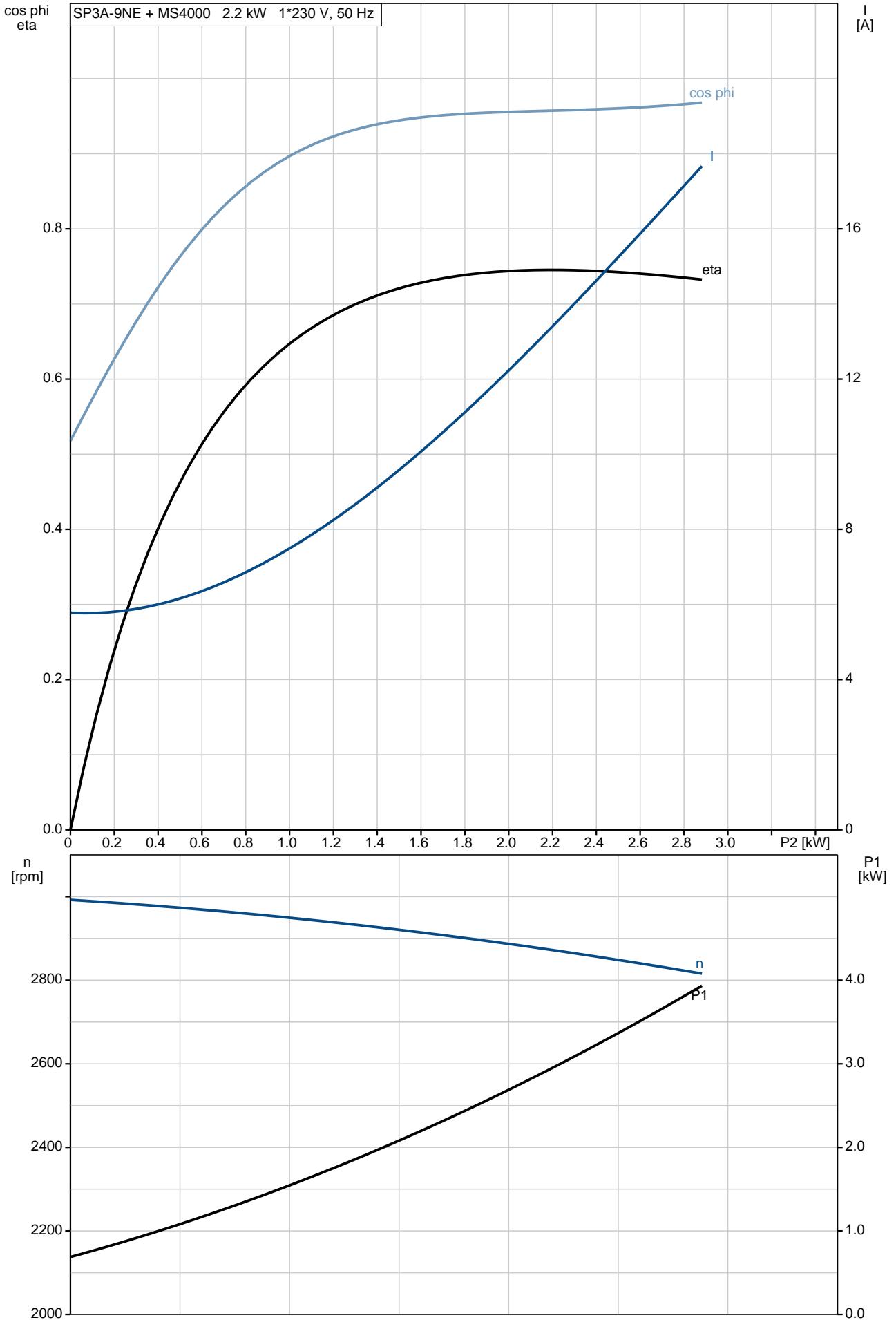

On request SP 3A-9NE 50 Hz

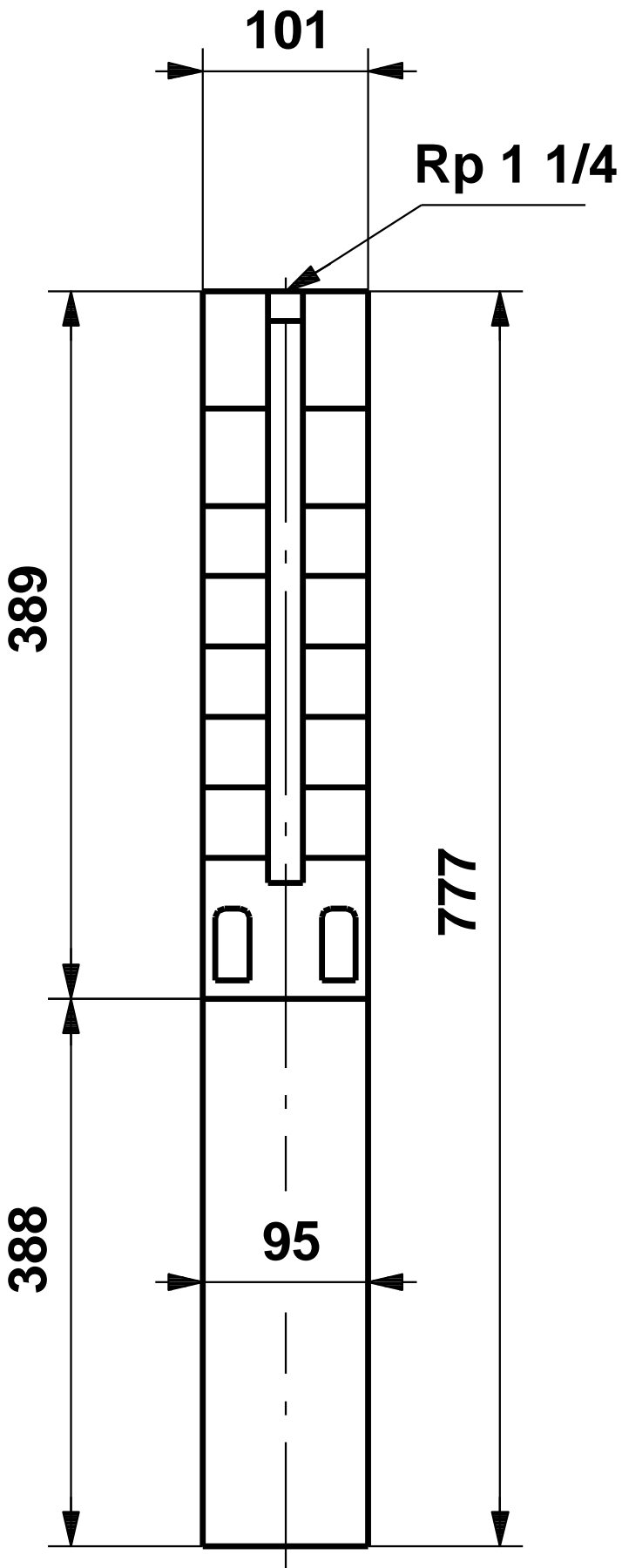

Note! All units are in [mm] unless others are stated.
Disclaimer: This simplified dimensional drawing does not show all details.

Exploded view

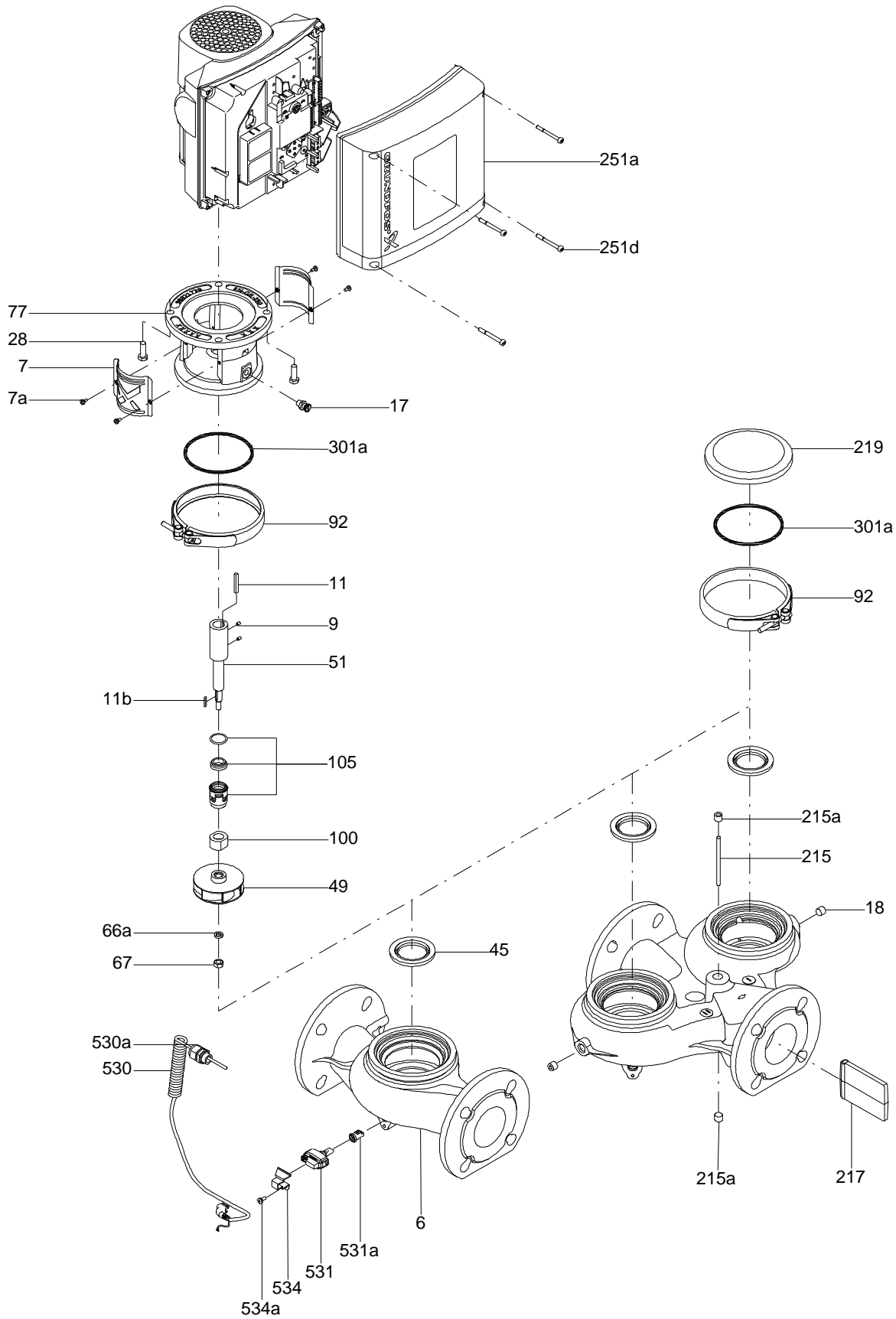

Sectional drawing (TM058200 for TPE2,TPE3)



TM058200

Exploded view (TM057026 for MGE model H/I)

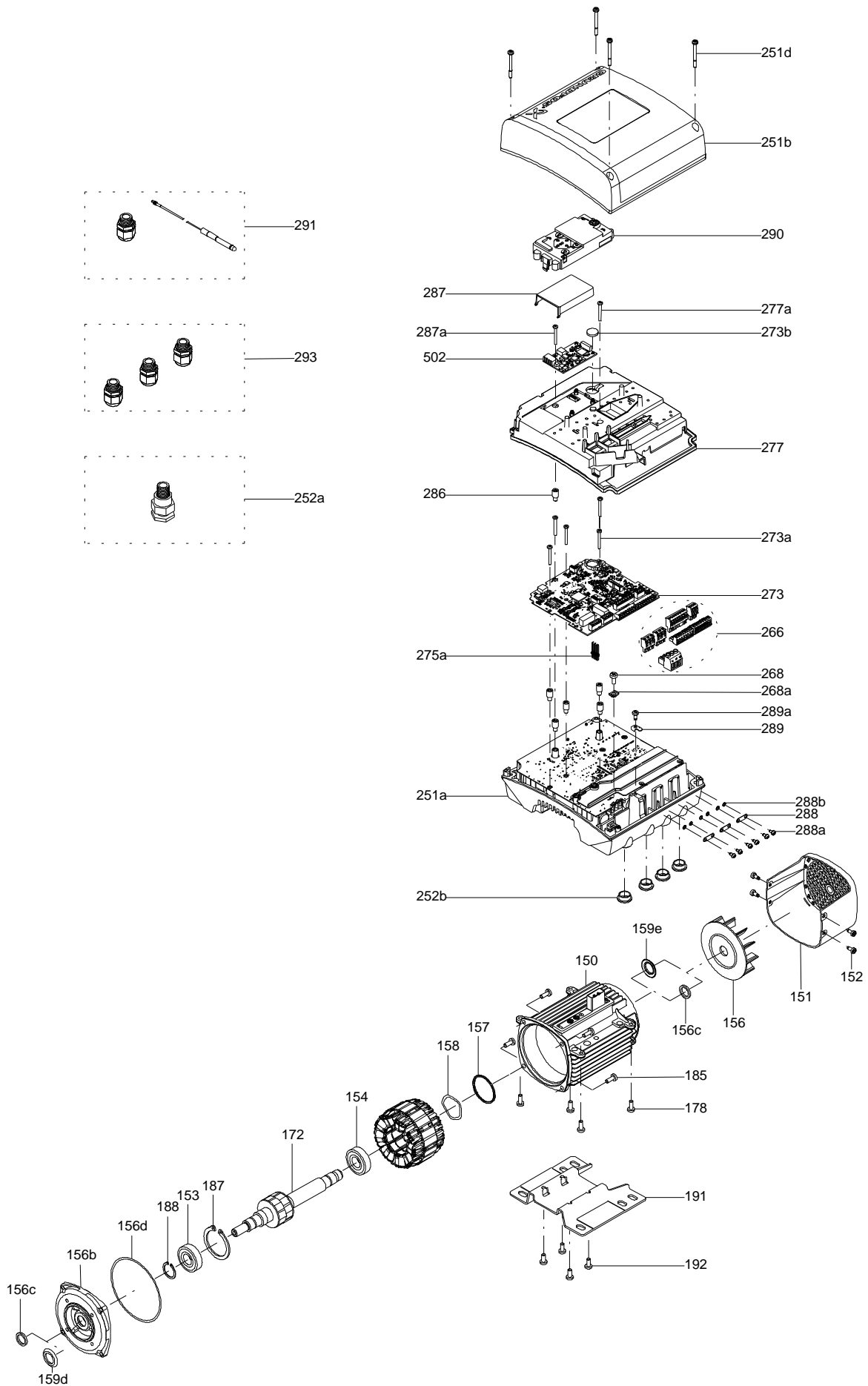

Parts list SP 3A-9NE, Product No. On request
Valid from 18.4.1995 (9516)

Pos	Description	Annotation	Données de classification	Référence	Quantité	Unité
-	Pump w/o motor				1	pcs
	Stop ring				1	
	Retainer				1	
- 1	Valve casing cpl.				1	
	Valve casing				1	
6	Bearing				1	
- 9	Intermediate chamber cpl.				9	
	Chamber				1	
7	Seal ring				1	
- 10	Chamber cpl.				1	
7	Seal ring				1	
- 13a	Impeller cpl.				9	
	Impeller				1	
- 11	Split cone nut				1	
	Split cone nut					
11a	O-ring					
12	Split cone				1	
14	Suction interconnector				1	
15	Strainer				1	
16	Shaft cpl.		Length (mm): 297		1	
17	Strap cpl.		Length (mm): 317		4	
			Thread: M8			
18	Cable guard cpl.				1	
18d	Hex nut				2	
19	Nut				4	
78	Nameplate				1	
-	Motor				1	pcs
1	Stator w/housing				1	
2	Shaft w/rotor				1	
3	Thrust ring support cpl.				1	
4	Radial bearing				1	
5	Bearing pipe				1	
6	Thrust bearing				1	
7	Lock ring				1	
10	Bearing retainer				1	
11	Adjusting screw				1	
12	Diaphragm				1	
13	End shield				1	
15	Nut				1	
16	Lock washer				1	
18	Nut		Thread: M8 DIN 934		1	
21	Nut		Thread: M8 DIN 934		4	
22	Staybolt		Thread: M8 X M8		3	
22a	Staybolt		Thread: M8 X M8 R		1	
22b	Cheese head screw				1	
22c	O-ring		Diameter: 4		1	
			Material type: FKM			
			Thickness: 1			
24	O-ring		Diameter: 40		1	
			Material type: FKM			
			Thickness: 2			
25	Shaft seal housing				1	
27	Spline protector				1	
28	Supporting ring				1	
29	Sand shield				1	
30	Compression spring				1	
31	Supporting ring				1	
32	Shaft seal cpl.				1	
- 34	Shaft seal cpl.				1	

Pos	Description	Annotation	Données de classification	Référence	Quantité	Unité
	Seal ring				1	
	Seal ring, rotating				1	
33	O-ring		Diameter: 16		1	
			Material type: VITON			
			Thickness: 2.5			

Disclaimer: The information about the Grundfos pump in this document may be outdated.

Data may be subject to alterations without further notice.

Please contact us to verify the data above is still accurate/up-to-date.

All information is copyright Grundfos.



info@lenntech.com

<https://www.lenntech.com>

tel. +31 152 610 900

fax. +31 152 616 289