

## Durable in Process, Smart in Analytics

### M400 ISM Multi-parameter Transmitter



#### Robustness

- Touchscreen and soft keys offer convenient operation even for the harshest applications
- Rugged design for industrial environments and temperature extremes



#### Predictive Maintenance

- Advanced ISM functionality provides predictive maintenance tools to prevent unplanned shutdowns and reduce maintenance
- iMonitor™ display for ISM diagnostics information at a glance
- Real-time online monitoring via HART



#### Superior Flexibility

- Multi-parameter transmitter covers pH, oDO, and CO<sub>2</sub> sensors
- Flexible transmitter models with segment-specific parameter compatibility for target applications
- Compatible with major asset management tools



#### Error-free Operation

- Fast commissioning and error-free startup thanks to Plug and Measure functionality
- Direct connection of sensors pre-calibrated via iSense™ software
- Safe and user-friendly sensor wiring
- Configuration via transmitter configuration tool or USB stick saves time



ISM®



#### Reliable and Intelligent for Advanced Process Control

The multi-parameter M400 transmitter series features Intelligent Sensor Management (ISM®) technology and covers pH/ORP, oxygen (dissolved), dissolved carbon dioxide or conductivity depending on the model you choose.

The high contrast black and white touchscreen together with four soft keys, allows you to operate the transmitter in the harshest applications without compromising user ergonomics. Online diagnostics information lets you know when it is time to replace, maintain or calibrate sensors equipped with ISM technology. The HART communication protocol provides easy integration of sensor diagnostics into process control systems.

## Technical data of the M400 4-wire transmitter series

Power supply	100 to 240VAC 50/60 Hz 10VA 20 to 30VDC 10VA
Analog outputs <sup>1)</sup>	4 × 0/4 to 20 mA, 22 mA alarm, galvanically isolated (with HART)
Relays	2 SPDT, mechanical, 250 VAC or 30 VDC, 3 A 2 SPST, Reed, 250 VAC or 250 VDC, 0.5 A, 10 W
Digital inputs	2
Analog input <sup>2)</sup>	1 × 0/4 to 20 mA
PID controller	1
User interface	4.0" TFT b/w touchscreen, 320 × 240 pixels
Languages	10 (English, German, French, Italian, Spanish, Portuguese, Russian, Japanese, Korean and Chinese)
USB interface	1 USB host: data logging, loading or saving configuration 1 USB device: software update interface
Ambient temperature	-20 to +50 °C (-4 to 122 °F)
Relative humidity	0 to 90 % non-condensing
Enclosure material	Aluminum die cast
Enclosure rating	IP 66/NEMA 4X
Approvals and certificates	CE, ATEX Zone II, cCSAus ClI Div2 <sup>1)</sup>

<sup>1)</sup> for M400 Type 2 ISM.

## M400 parameter fit guide

	M400 Type 1 ISM	M400 Type 2 ISM
pH/ORP	•	•
pH/pNa	•	•
UniCond 2-e/4-e	•	•
Conductivity 2-e	-	-
Conductivity 4-e	•	•
Amp. DO ppm/ppb/trace	-	•/• <sup>1)</sup> /-
Opt. DO ppm/ppb	-	•/• <sup>1)</sup>
Amp. O <sub>2</sub> gas ppm/ppb/trace	-	-/-/-
Opt. O <sub>2</sub> gas ppm	-	-
Dissolved Ozone	-	•
Dissolved Carbon Dioxide	-	•
CO <sub>2</sub> hi	-	-
GPro 500 TDL	-	-

<sup>1)</sup> Thornton high performance dissolved oxygen and pure water optical sensors only.

## Ordering information

Transmitter	Order no.
M400 Type 1 ISM	30 490 171
M400 Type 2 ISM	30 490 172

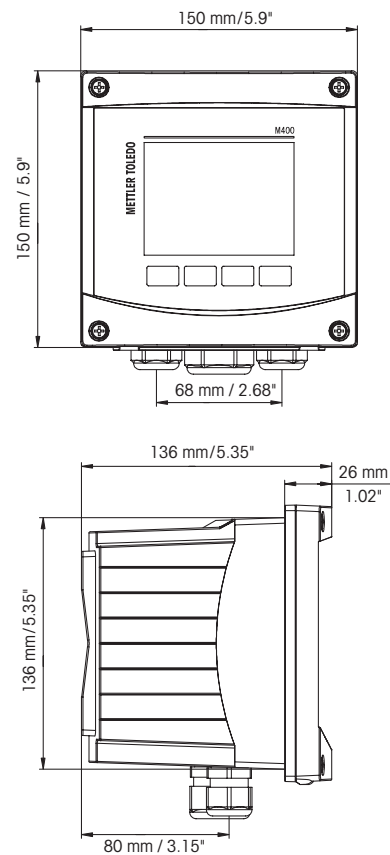

Dimension Drawing M400



**METTLER TOLEDO Group**  
Process Analytics

ISM, iSense, iMonitor and GPro are trademarks of the METTLER TOLEDO Group. Subject to technical changes.  
© 10/2018 Mettler-Toledo GmbH.  
Printed in Switzerland. PA0125en C.

For more information

**LENNTECH**  
WATER TREATMENT SOLUTIONS

info@lennotech.com Tel. +31-152-610-900  
www.lennotech.com Fax. +31-152-616-289