

IWAKI
 ELECTROMAGNETIC
 METERING
 PUMPS

EWN-A



Electromagnetic metering pumps Automatic air vent type

This type equips automatic air vent mechanism. An air vent valve built-in pump chamber enables reliable air venting. Also equipped manual air vent valve enables easy pressure release in discharge piping. Gaseous liquid such as sodium hypochlorite or hydrogen peroxide can be injected without gas locking.

- Entrained air is automatically expelled from the pump head. No special degassing is needed.
- The pump immediately resumes operation without gas lock even after a long period of stoppage.
- Use the air vent port manually for quick release of discharge line pressure.
- Capable of pumping concentrated sodium hypochlorite

Principle of operation

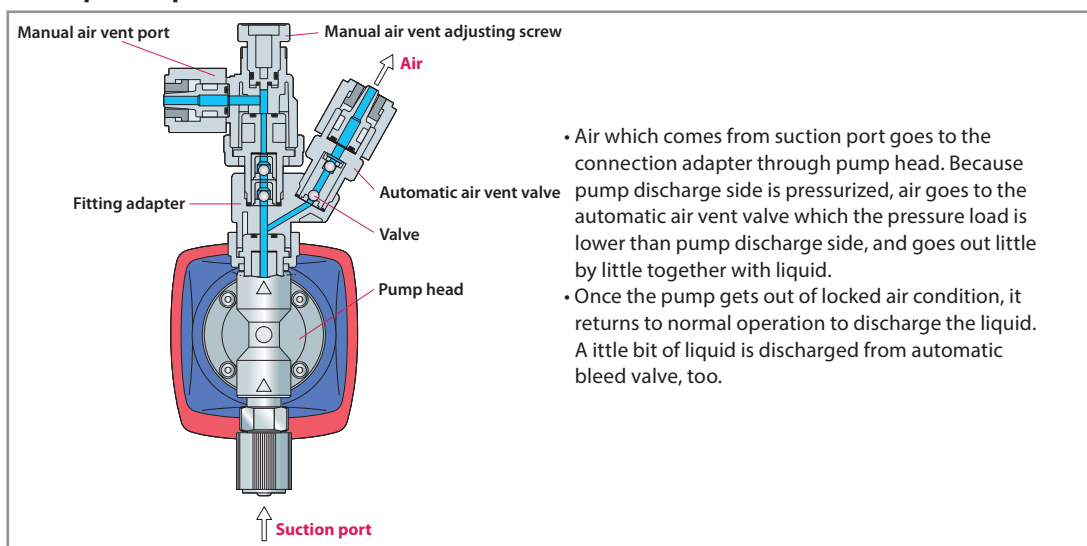

Pump identification

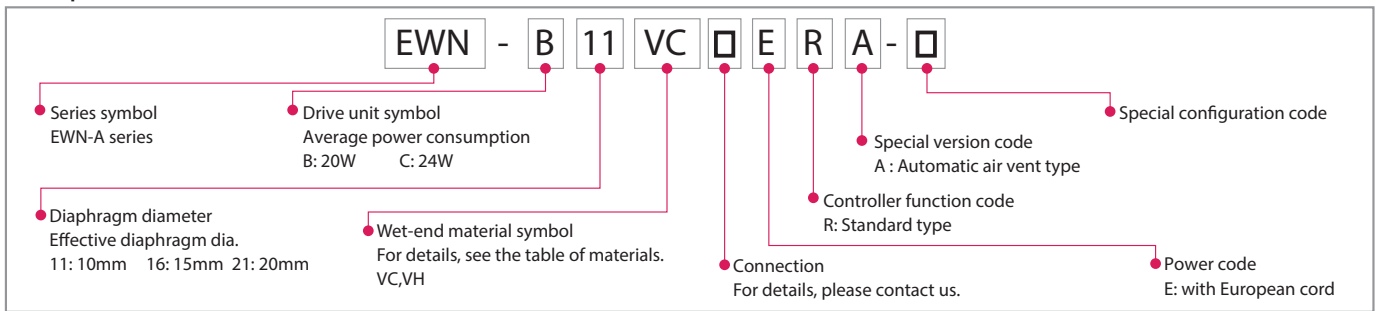

Wet-end materials

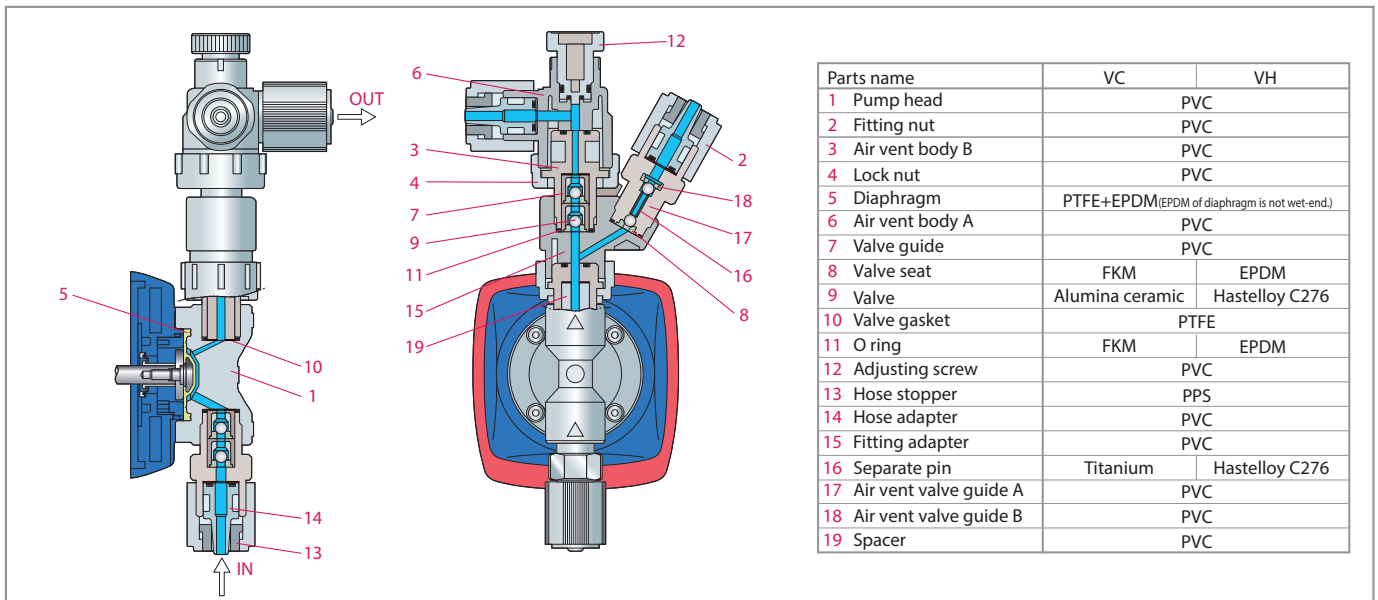

Specifications of pump

Model	EWN-B11	EWN-B16	EWN-C16	EWN-C21
Capacity	L/hr 1.8	3.3	3.9	6.6
	mL/min 30	55	65	110
Discharge capacity per shot	mL/shot 0.04-0.08	0.08-0.15	0.07-0.18	0.12-0.31
Rated discharge pressure	MPa 1.0	0.7	1.0	0.7
Stroke length adjustable range	% 50-100	40-100		
Stroke rate	% (spm) 0.1-100 (1-360)			
Standard connection (Hose dia)	mm ø4×ø6			
Current	A 0.8	1.2		
Average power consumption	W 20	24		
Power Voltage	100 - 240 VAC 50/60Hz			

- Note 1: Each discharge capacity shown above is at the discharge pressure (stroke length 100%, stroke rate 100%) and increases as a discharge pressure reduces.
- Note 2: The performance is based on pumping clean water at ambient temperature at rated voltage.
- Note 3: Liquid temperature range: VC/VH types -10 to 40 °C
Liquid characteristics must not change (viscosity, freezing or slurries contained)

Dimensions in mm

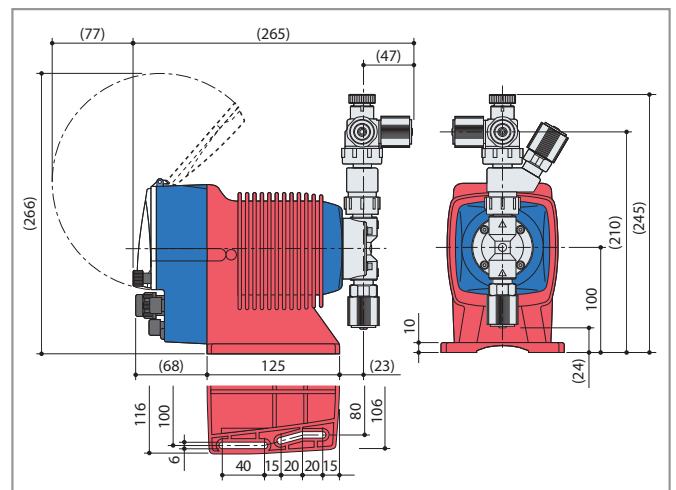

LENNTECH
WATER TREATMENT SOLUTIONS

info@lennotech.com Tel. +31-152-610-900
www.lennotech.com Fax. +31-152-616-289

⚠ Caution for safety use: Before use of pump, read instruction manual carefully to use the product correctly.
Actual pumps may differ from the photos. Specifications and dimensions are subject to change without prior notice. For further details please contact us.

⚠ Legal attention related to export.
Our products and/or parts of products fall in the category of goods contained in control list of international regime for export control. Please be reminded that export license could be required when products are exported due to export control regulations of countries.

