

Model SL8040Xf		250 psi / SIDE PORT	
DESIGN PRESSURE AT 120 °F (50°C)	18 BAR (250 PSI)	OPERATING pH RANGE	3-11
MINIMUM OPERATING TEMP.	20°F (-7°C)	CLEANING pH RANGE	2-12
MAXIMUM OPERATING TEMP.	120°F (50°C)		(less than 30 minutes)
FACTORY TEST PRESSURE	375 PSI	APPLICATION	TYP. BRACKISH WATERS
BURST PRESSURE	1500 PSI	FEEDWATERS TDS	≤ 10000 ppm MAX

INTENDED USE

The BEKAERT Model **SL8040Xf** Pressure Vessel is designed for continuous use as housing for membrane filtration elements to purify typical brackish waters at any positive pressure up to 250 PSI. The **SL8040Xf** will accommodate any make of eight-inch nominal diameter spiral-wound element as well as many hollow fibre elements. The element interface hardware for the specified element is supplied with the vessel.

The Model **SL8040Xf** has been designed to meet the standards of the American Society of Mechanical Engineers (ASME), Boiler and Pressure Vessel Code, Section X. At an additional cost, vessels can be inspected during fabrication by an ASME Authorized Inspector and Code stamped.

The Model **SL8040Xf** must be installed, operated and maintained using good industrial practice and following the precautions listed in order to help assure safe operation and a long service life. Misuse, improper installation or operation may result in severe bodily harm or property damage and will void the vessel warranty. Therefore, review

and follow the safeguards listed below **before** placing the vessels into service.

The filament-wound reinforced plastic shell of this vessel must be allowed to expand under pressure. Any undue restraint at the support points or piping connections can cause non-repairable leaks to develop in the shell. This vessel must not be subjected to excessive stress caused by bending moments acting at the side ports in the fiberglass shell.

The end closures of the vessel must be kept dry and free of corrosion at all times. Failure to do so may result in deterioration that can lead to catastrophic failure of the vessel heads.

When requested, Bekaert Progressive Composites will assist the purchaser in determining the suitability of this standard vessel design for their operating environment. However, the final determination including the evaluation of the materials of construction for use in the specific corrosive environment shall be the responsibility of the purchaser. Alternate materials of construction may be available on special order.

PRECAUTIONS

Follow all instructions.

Failure to take every precaution listed will void the vessel warranty and may result in vessel failure.

Mount shell using furnished hardware.

Following the recommended span(s) mount the vessel until the straps are "just snug".

Use flexible type groove-end pipe couplings.

Using Victaulic™ style 77 or equal fittings at each port, allow a full .3.175 mm gap between each port /manifold connection.

Maximize the connection flexibility.

Position the vessel and the piping to so that the vessel can grow in length and diameter under pressure without any undue restraint. Δ DIA = 0.012 in (0.3 mm) and Δ L = 0.15 in (4 mm) for a length code 8 vessel.

Provide overpressure protection.

Set the safety device at not more than 105% design pressure.

Inspect end closures regularly.

Replace damaged or deteriorated components and correct the cause of any corrosion.

Relieve system pressure before working on the vessel.

Working on vessels that are under pressure may result in bodily harm and/or property damage.

Never support other components with the vessel.

Hanging piping manifolds or supporting other components with the vessel may result in vessel damage.

Do not over tighten the Permeate Port connection.

Tightening the connection more than one turn past hand tight will damage the port.

Ensure that the Thrust Ring is installed downstream.

Operating without a thrust ring may cause membrane damage.

Double check end closure installation.

Ensure that retaining ring is in place and fully seated.

Never operate the vessel in excess of its ratings.

This practice will void the vessel warranty, shorten vessel life and could lead to bodily harm or property damage.

Do not operate the vessel permeate port over 8.5 bar (125 psi).

Permeate pressure in excess of 8,5 bar (125 psi) must be approved by the factory prior to operation.

Operate the vessel in only positive pressure applications.

This vessel is not designed for vacuum conditions.

Flush the vessel before system shut down.

Some feed waters may cause corrosion under static conditions. Flushing with non-corrosive permeate is recommended.

Operate the vessel within the recommended pH range.

The vessel is designed for continuous use at a pH of 3-11 and for intermittent cleaning (less than 30 min. at a pH of 2-12).

HEAD LOADING PROCEDURE

STEP 1: Inspect The Shell

Before installing the head, check the inside surface of the shell for any imperfections or foreign matter. Remove all foreign matter using a mild soap solution and rinse with clean water.

STEP 2: Head Seal And Shell Lubrication

Ensure that the head seal is covered with a thin layer of glycerin and is free from any dirt or dust contamination. Then lubricate the inside of the shell starting directly inboard of the retaining ring groove and into the vessel bore. Only a thin layer is required. Silicone lubricants can also be used; however, care should be taken to use as little as possible. Check with your membrane supplier before using these lubricants as they can foul membranes.

STEP 3: Install Head

Position the vessel and the closing head in order to have a perfect alignment of connections. Do not rotate the head once introduced into the vessel as this may damage the head seal. Grasp the bearing plate and place it perpendicular to the vessel axis, pushing it straight on. Introduce the bearing plate by the non-treaded holes.

STEP 4: Install Interlocking

Place the locking ring set (800000/12). Put the yellow ring (805003/8) towards the bearing plate until it touches the bearing plate. Thread the three securing screws (80000/16) into the bearing plate two turns. By using the back of a screwdriver, tap the yellow ring into its place so it seats completely round the bearing plate. Tighten the securing rings but make sure you don't over-tighten the screws.

STEP 5: Reconnect Permeate port

Reconnect the permeate manifolding to the permeate port.

STEP 6: Pressurize System

Before starting the system, double check that each head has been correctly installed and that all piping connections are in place. After ensuring that all required precautions have been taken, start the system.

STEP 7: Check For leaks

After system start up, verify that all connections are leak free. Fix any leaks at this time to prevent corrosion that may lead to component deterioration and possibly unsafe operation.

HEAD REMOVAL PROCEDURE

STEP 1: Shut Down System

Shut down system and take all steps necessary to relieve system pressure from the vessel.

STEP 2: Disconnect Piping

Carefully disconnect the feed and permeate piping from the vessel. Mark the feed port location by marking the shell for easier installation. Set this piping in a secure place for re-assembly.

STEP 3: Check End Closure

Examine the end closure for any corrosion or damage. Remove any corrosion with a wire brush and flush away the deposits with clean water. Order replacement components as required.

STEP 4: Remove interlocking

Remove the three securing screws (800000/16) from the yellow ring securing ring (805003/8). Now place the two screws into the treaded holes of the yellow securing ring until they touch the bearing plate. Hold the three screws tight and pull the securing ring carefully out. If it is difficult to pull the securing out, then use the screws as jacking screws by turning them in 1/4. Once the ring starts moving, repeat the procedure twice.

Use a rubber hammer with a wooden block and tap onto the bearing plate. This should free the locking ring segments (800000/12). Rotate the locking ring set removing each time the upper segment. After removing the segments, clean the vessel with water.

STEP 5: Remove Head

While holding the permeate port with your hand, simply pull the head from the shell. In some instances it may be required to thread a connection in to the permeate port and gently rock the head up and down to release the head from the shell.

HEAD REBUILDING

Prior to following this procedure, remove the head following the procedure listed.

STEP 1: Remove Seeger ring

Take out the Seeger ring that fixes the outlet adapter onto the bearing plate.

STEP 2: Remove the adapter

Remove the outlet adapter (PVC-part) from the bearing plate and remove the sealing plate.

STEP 3: Remove Seals

Remove the seal from the permeate port and set aside. Using a small tool, such as a screwdriver or a paper clip, remove the seal from the inside of the permeate port and set aside.

STEP 4: Clean All Components

Using a mild soap solution, clean each component, rinse with fresh water and then dry with oil-free compressed air or a lint free towel.

STEP 5: Inspect Components

Examine each component for corrosion or damage that may affect the performance of the vessel. Replace any components that have corrosion or visual damage. In addition, carefully inspect each seal for damage or wear. It is recommended to replace each seal at this time. Please be aware that seal condition may affect system performance.

STEP 6: Lubricate Seals

Using extreme care, coat each seal with a thin layer of glycerin. Only a thin layer is required. Silicone lubricants can also be used; however, care should be taken to use as little as possible. Check with your membrane supplier before using these lubricants as they can foul membranes.

STEP 7: Reassemble Head

Reversing the removal procedure, reassemble the head. Please note that a new permeate port retaining ring may be required to ensure correct component performance.

Model SL8040Xf 250 psi / SIDE PORT

File: C:/Bitor/tubos80/CabSL80f Plan: 805004 Rev.: 1

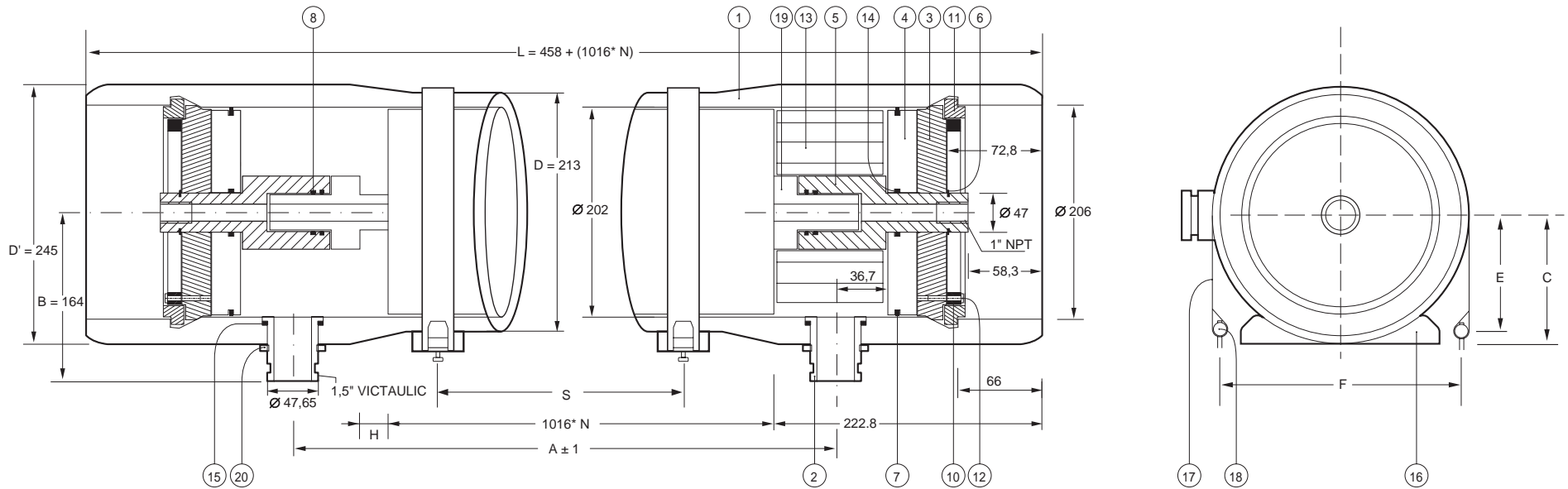

H = play using nominal measures

REFER	CONCEPT	MATERIAL	QUANT	DRAW. (250 psi)
1	Shell	Roving-Epoxy	1	805004/20
2	Outlet Pipe Cap	Stainless Steel S32750	2	805001/71
3	Bearing Plate	Hard Anodized Al 6061 T6 or 6082 T6	2	805004/3
4	Sealing Plate	PVC (grey)	2	805004/4
5	Outlet Adapter	PVC	2	805004/5
6	Seeger Ring	Stainless Steel	2	
7	Head Seal	EPDM (square)	2	800000/17
8	O-Ring 36	EPDM	4	800000/15
10	Securing Ring	Epoxy-Glass	2	805003/8
11	Locking Ring Set	Stainless Steel 316L	2	800000/12
12	Securing Screw	St Steel DIN 912 M8 x 20	6	800000/16
13	Thrust Ring	Nylon	1	805001/13
14	O-Ring 49	EPDM	2	800000/21
15	O-Ring	EPDM (square)	2	805003/15
16	Saddle	Polyurethane	2	800000/11
17/18	Strap	Stainless Steel 304	2	800004/9-10
19	Membrane Adapter	PET	2	D/MODEL
20	Outlet Pipe Cap Nut	Stainless Steel S32750	2	805003/72

P	MEM	MODEL	L	A	S	D	E	C	B	F	D'
2	1	SL80401f	1474	1143	710	213	107.7	116.5	164	245	245
5	2	SL80402f	2490	2159	1420	213	107.7	116.5	164	245	245
0	3	SL80403f	3506	3175	2030	213	107.7	116.5	164	245	245
	4	SL80404f	4522	4191	2625	213	107.7	116.5	164	245	245
	5	SL80405f	5538	5207	1980x2	213	107.7	116.5	164	245	245
p	6	SL80406f	6554	6223	2340x2	213	107.7	116.5	164	245	245
s	7	SL80407f	7570	7239	2690x2	213	107.7	116.5	164	245	245
i	8	SL80408f	8586	8255	3050x2	213	107.7	116.5	164	245	245

From fifth membrane, the vessels are fixed by three supports being centered one of them.

DESIGN SPECIFICATION

1. Vessel will be built up following ASME Code Section X Classcut filament winding.
2. Manufacturer can supply following documentation with the vessels:
 - Operating and maintenance instructions.
 - Technical Guide of application.
 - Drawings.
 - Copy of Manufacturers Data Report.
3. Vessel is supplied complete, with closures, connections and fixing elements. Membrane interconnectors are not included.
4. Vessel has enough diameter and length to contain the membrane elements for Reverse Osmosis procedure.
 - Standard membrane length: 40"
 - Standard membrane diameter: 8"
5. Materials will be as follows:
 - Shell: - Glass fibre - epoxy resin, hot cured
 - Head: - Bearing plate. Aluminum 6061-T6 or 6082-T6 Hard anodized
 - Feed port: Stainless steel SA-790 Designation UNS: S32750
6. Closing heads will be in accordance with drawing 805004.

IDENTIFICATION CODE

The model-numbering is built up as follows:

AA	XX	XX	X	a
1	2	3	4	5

- 1: Model of the Vessel (OI, SL, BK)
- 2: Diameter of the membrane (80 = 8", 40 = 4", 25 = 2,5")
- 3: Length of the membrane in inches
- 4: Number of membranes
- 5: Pressure identifications: h (1200 psi), a (1000 psi), m (600 psi), b (400 psi), f (250 psi)

Example: OI80403m is a vessel, OI (end-ported), used to house 3 membranes of 8" in diameter, 40" in length and operating under a pressure of 600 psi.

LENNTECH

info@lenntech.com Tel. +31-152-610-900
www.lenntech.com Fax. +31-152-616-289

 **BEKAERT**