

**Series ALLMAG CMA**

Volute Casing Centrifugal Pump with Magdrive in block design up to PN 16

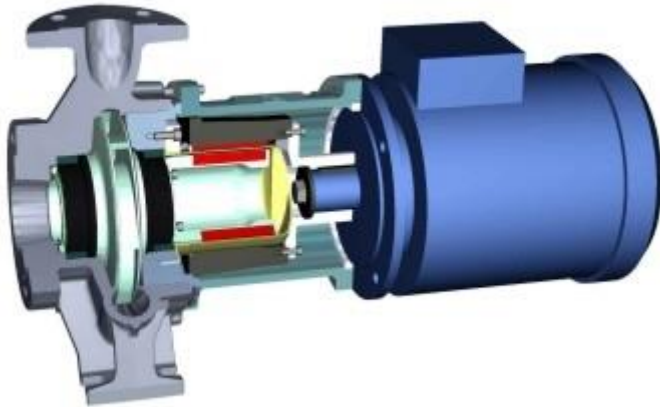

**Pumped liquid**

Aggressive fluids, full desalinated water etc.

**Main fields of application**

Process engineering and chemical industry, marine and offshore engineering (sea water desalination, chemical tanker)

**Performance data Series ALLMAG CMA**

Capacity	Q	up to 80	m <sup>3</sup> /h
Delivery head	H	up to 55	m
Discharge pressure	pd	up to 16	bar
Fluid temperature	t	up to 150	°C

**Construction features**

- Casing dimension and rated output acc to DIN EN 22858/ISO 2858
- Technical execution acc. DIN EN ISO 5199/ISO 5199
- Block design (Motor attached to pump via flange or lantern)
- Dry installation
- Vertical installation
- Horizontal installation
- Stub shaft für IEC motor
- With magnetic drive