

Design Pressure = 450 PSI @ 120 °F
 Min. Design Temperature = 20 °F @ 450 PSI
 Hydrotest Pressure = 495 PSI

450 PSI
SIDE PORT

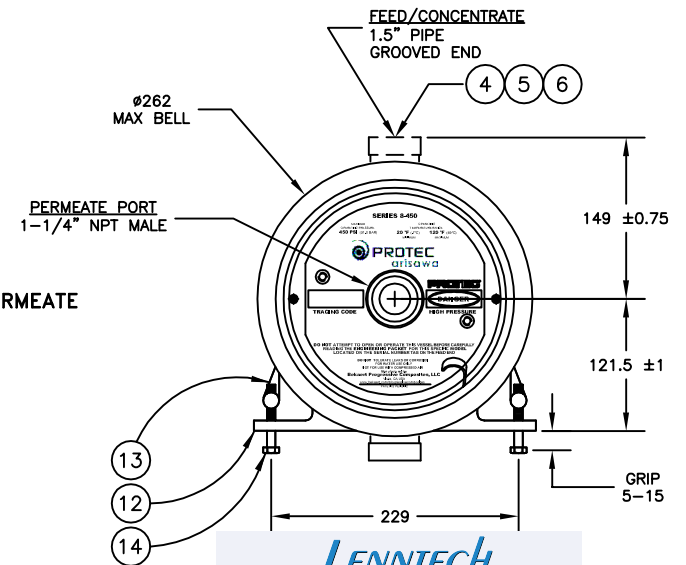
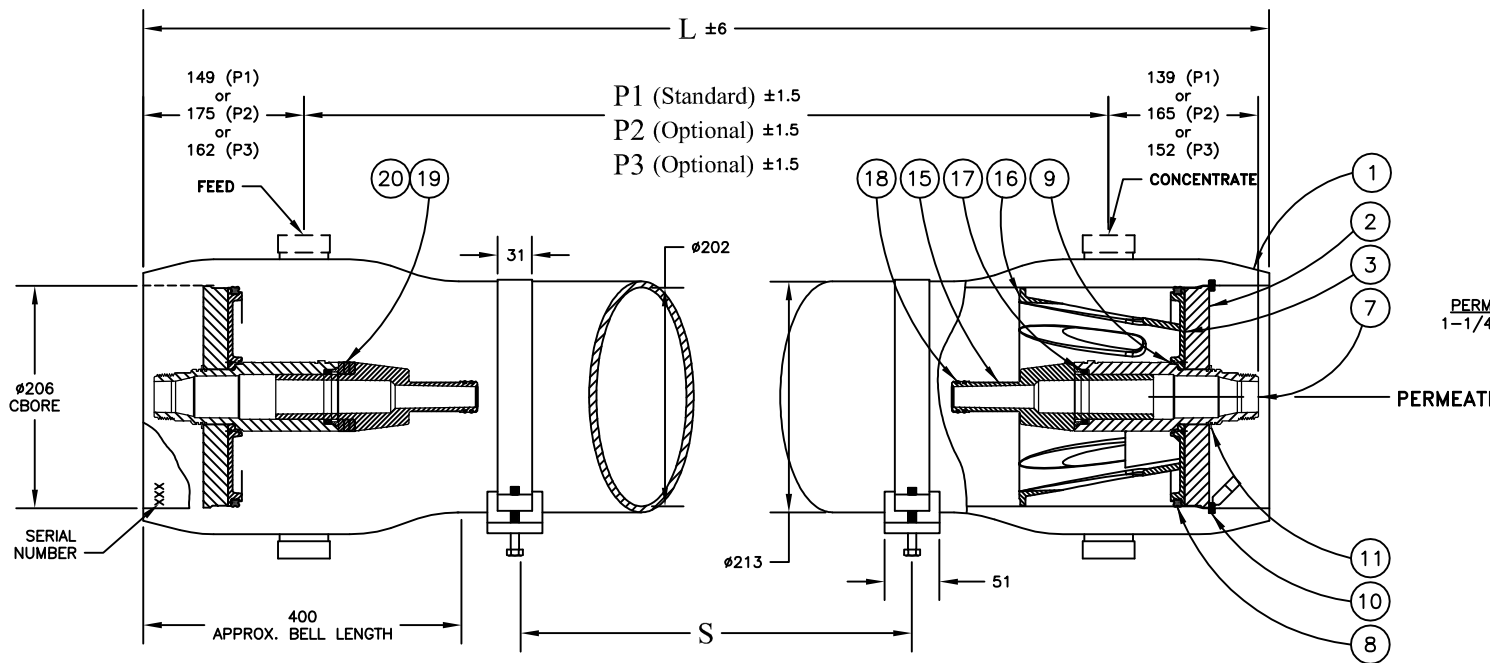

LENNTECH
 Water Treatment Solutions
 info@lenntech.com Tel. +31-152-610-900
 www.lenntech.com Fax. +31-152-616-289

NOTES:
 DIMENSIONS IN MM.
 FOR REFERENCE ONLY, NOT FOR CONSTRUCTION UNLESS CERTIFIED
 SHIMMING OF THE SADDLES MAY BE REQUIRED
 CENTER VESSEL ON 2 OR 3 SUPPORTS AT SPAN(S) "S".
 INCORRECT MANIFOLDING WILL CAUSE SEVERE LOCAL STRESS AROUND PORT AND MAY RESULT IN LEAKS AND PREMATURE FAILURE. TAKE EVERY PRECAUTION LISTED IN THE ENGINEERING PACKET OR USERS MANUAL.
 INTERNAL PERMEATE PRESSURE MUST NOT EXCEED 125 PSI.
 ASME SECTION X, RP CODE STAMP OPTIONAL
 SPECIFICATIONS SUBJECT TO CHANGE WITHOUT NOTICE



PRO 8-450-SP

Shell Length Code	L mm	P1 STANDARD mm	P2 Optional mm	P3 Optional mm	S Span mm	Empty Weight kg
-1	1492	1194	1143	1168.4	1@635	40
-1.5	2000	1702	1651	1676.4	1@1067	44
-2	2508	2210	2159	2184.4	1@1422	47
-3	3524	3226	3175	3200.4	1@2032	54
-4	4540	4242	4191	4216.4	2@1626	60
-5	5556	5258	5207	5232.4	2@1981	68
-6	6572	6274	6223	6248.4	2@2337	75
-7	7587	7290	7239	7264.4	2@2692	82
-7.5	8095	7798	7747	7772.4	2@2896	86
-8	8603	8306	8255	8280.4	2@3048	89

ITEM	QTY	P/N	DESCRIPTION	MATERIAL
1	1	4080020	Shell	Filament Wound, Epoxy FRP
2	2	4080030	Bearing Plate	6061-T6 Aluminum, Anodized
3	2	4080177-3	Sealing Plate	Noryl
4	2	4080244	Feed/Concentrate Port, 1-1/2", "D"	Stainless Steel, 316L
5	4	6121187	Retaining Ring, F/C Port, 1-1/2", "D"	Stainless Steel, 316L
6	2	6184604N	O-Ring Seal, F/C Port, 1-1/2", "D"	Ethylene Propylene
7	2	4080309	Permeate Port	Noryl
8	2	610442MK	Head Seal	Ethylene Propylene
9	2	6180229N	Permeate Port Seal	Ethylene Propylene
10	2	4080320	Retaining Ring w/ Finger Pull	Stainless Steel, 316L
11	2	6121200	Retaining Ring, Permeate Port	Stainless Steel, 316L
12	2*	4080174	Support Saddle	Thermoplastic Rubber
13	2	4080800	Strap Assembly [M8]	Stainless Steel, 316L
14	4	6150072	Strap Screw [M8x70mm]	Stainless Steel, A4
15	2	5080049	Adapter	Noryl
16	1	4080165-1	Thrust Cone	PVC Thermoplastic
17	2	6180326N	Adapter Seal	Ethylene Propylene
18	4	6180119N	PWT Seal	Ethylene Propylene
19	2	4080062-4	Shim, Adapter (5mm)	Noryl
20	2	4080704	Shim, Adapter (2mm)	Noryl

*3 each with shell length -4 and longer

ENGR BOA 27/11/15	ECO	REVISED 27/11/15	DRAWING 101003	REV W
QTY AL 27/11/15	15082			
MRKT GCM 27/11/15				