

Purolite[®] Resins for Potable and Ground Water Treatment

Potable and Ground Water Resins

Just ask Purolite.

PUROLITE[®]
ION EXCHANGE RESINS

Potable and Ground Water



Continued improvement in detection levels for contaminants in potable and ground water has led to the regulation of an increasing number of contaminants by regulatory bodies around the world. Over the last few years, new and tightened controls have been introduced for a variety of contaminants such as arsenic, perchlorate and uranium. Additionally, more is now understood about monitoring and control requirements for disinfection byproducts (DBP) such as trihalomethanes (THMs) and haloacetic acids (HAA) which are formed in some waters by the addition of chlorine and chlorine derivatives. As a result, increased requirements for removal of naturally occurring organic matter (TOC) before disinfection is now being applied to some waters.

In arid regions, greater attention is being paid to treatment processes that minimize the environmental impact of wastewater and chemical discharges including spent regenerant chemicals..

Purolite® is at the forefront in meeting these new challenges, continuing to develop specialized ion exchange resins and adsorbent solutions focused on reducing waste and operating costs. The wide variety of contaminants needing removal often requires a customized approach. Some contaminants are removed by relying largely on the ion exchange properties of our resins (e.g. nitrate and uranium) while others (e.g. perchlorate and TOC) rely on the combination of unique ionic, adsorptive and hydrophobic characteristics of our specialty resins.

While ion exchange resins can be used to selectively remove specific contaminants, it is recognized that membrane and other broad-based removal technologies are suitable alternatives for reduction of high total dissolved solids (TDS) in brackish water supplies. Membrane fouling from colloidal particulate matter, TOC and scale forming compounds can limit the percentage of permeate water that is recoverable. Purolite's membrane pretreatment resins can reduce colloidal particulates, TOC and scaling potential, to give a lower silt density index (SDI) and increase membrane operating efficiency and recovery rates.

Table 1 – Purolite Range of Ground and Potable Water Treatment Resins

Contaminant	Recommended Purolite® Resins	
Arsenic	FerrIX A33E A300E, A200E	Iron-infused adsorptive media – single use or offsite regenerable. Type II strong base anion (SBA) – brine regenerable.
Barium / Radium / Strontium	SST60 PPC100	Fouling resistant shell-core strong acid cation (SAC) – brine regenerable. Narrow particle size (SAC) for packed beds.
Color / Tannin Disinfection Byproducts Precursors (TOC)	A860, A850, A500P TANEX	Brine regenerable acrylic and styrenic SBAs. Brine regenerable proprietary colloidal scavenging SBA resin.
Iron & Manganese	SST60	Fouling resistant shell-core SAC – brine regenerable; handles >20 ppm Fe.
Nitrate	A520E A300E, A200E	Nitrate selective. Type II SBA (can also use A400E or A600E Type I SBAs).
Perchlorate, technetium	A532E, A530E	Perchlorate selective resins (can also use A520E, A600E).
Uranium	A300E, A400E A600E, A850	Brine regenerable or single use.

Table 2 – Purolite Recommendations for Membrane Pretreatment

Membrane Pretreatment	Recommended Purolite® Resins	
Colloidal Particulate reduction Silt Density Index reduction TOC reduction	MPR1000	A proprietary blend of patented colloidal scavenger and TOC removal resins - patent pending.
Barium, Strontium, Hardness reduction	SST60	Fouling resistant shell-core strong acid cation (SAC) – brine regenerable Regenerable with RO reject water using Purolite’s Cyclic Ion Exchange (CIX) process or with standard brine.

Table 1 highlights recommended treatment approaches for some of the major contaminants currently regulated. **Table 2** outlines our recommendations for membrane pretreatment. For applications not listed please contact **PUROLITE**.

Applications

Arsenic Removal

Overview: Toxic substance - regulated to varying degrees globally – MCL of 10 ppb in USA.

Treatment: Our **FerrIX™ A33E**, an iron-infused anion resin, uses iron oxide to complex with either pentavalent (**As⁺⁵**) or trivalent (**As⁺³**) arsenic to reduce arsenic to typically < 2 ppb.

Advantages:

- Ideal for either municipal or domestic water systems requiring minimum operator attention
- Recommended for either single use or for applications needing offsite regeneration
- Both the virgin and offsite regenerated media are certified to NSF/ANSI 61 standard

For water systems in which brine regeneration is feasible, we recommend Purolite A300E or A200E anion resins which remove only the pentavalent form of arsenic. Pre-oxidation is recommended for converting the trivalent to the pentavalent form before removal by the resin. Any excess of oxidant must be removed before contact with the resin.

ORGANICS - Disinfection Byproducts Control / TOC / Color / Tannin Removal

Overview: Naturally occurring organic matters such as humic, fulvic and tannic acids present in water that is being disinfected can potentially result in the formation of a variety of toxic biproducts. These include trihalomethanes (THMs), trihaloacetic acids (HAAs) and bromate, and are currently regulated in several

countries. In the USA maximum concentrations of 80 ppb, 40 ppb and 10 ppb respectively are allowable.

Treatment: Purolite offers a variety of brine regenerable anion resins that can remove organic matter (collectively known as total organic carbon or TOC). The degree of reduction depends on the specific nature of the TOC as well as the choice of resin, its porosity, contact time and resistance to irreversible fouling. As a result, our product offering includes acrylic (SBA) resins (macroporous **Purolite A860** and gel type **A850**) as well as **Purolite A500P**, a macroporous styrenic SBA. For the more difficult to treat systems having both colloidal and dissolved TOC, we recommend our **TANEX** resin, a proprietary blend of resins, inclusive of a patented scavenger resin for colloidal particulate matter removal. Proper system design is important for good performance in all cases.



TOC Removal for DBP Control at City of Frisco, North Carolina

Advantages:

- Low operating cost with simple system design, requiring minimum operator attention.
- Multiple brine reuse possible in order to minimize the volume of waste water.
- Layering of anion resin on top of cation softening resin is possible to help reduce footprint and capital and operating costs.

- Multi-contaminant design approach is possible for simultaneous removal with other contaminants (see later)

Nitrate Removal

Overview: The World Health Organization recommends a maximum limit for nitrate of 50 ppm as NO₃ while the USA and other countries have set a maximum MCL of 45 ppm as NO₃.

Treatment: Nitrate removal using brine regenerable strong base anion resins is an established process. Nitrate selective resins, such as our **Purolite A520E**, were developed for use specifically in waters with high sulfate to nitrate ratios. For waters with low sulfate levels, our **Purolite A300E or A200E**, Type II SBA resins may offer better economics. Our Type I SBA resins, **Purolite A400E and A600E**, can also be used in special situations. **Purolite A520E** is however favored in this duty because nitrate that is fixed onto the bed is not displaced from **A520E** by sulfate as is the case for traditional Type 1 and II resins.

For municipal or community water systems in which onsite brine disposal is not permitted, haulage and offsite disposal of waste brine can be cost prohibitive. To address the problem, Purolite in conjunction with Applied Research Associates, have jointly developed the patent-pending **WIN** process for nitrate removal, using proprietary weak base anion resin technology. The **WIN** process, while requiring more operator attention, can significantly reduce waste volume compared to brine regenerable resins while producing a more benign nitrate waste.

Advantages:

- Single supplier for the full range of resin options available to the industry.
- Reliable easy-to-use PUREDESIGN™ software for ease of design.
- Customizable brine minimization approaches.
- Multi-contaminant design approach is possible for simultaneous removal with other contaminants (see later).

Perchlorate Removal

Overview: Perchlorate is a major health issue primarily in the USA. Trace parts per billion levels have been detected in potable water supplies in at least 22 states. Even though the US EPA is yet to set an MCL,

perchlorate is now regulated by several states at maximum levels ranging from 1 ppb to 6 ppb.

Treatment: Purolite continues to lead the industry with a comprehensive line of single-use and regenerable resins for perchlorate removal. Below is a listing of the major resins used for remediation of contaminated ground or potable water:

A532E – single use “load & burn”
A530E – single use or regenerable*
A520E – single use or regenerable*
A850 – brine regenerable

* Regeneration is possible using a tetrachloroferrate process patented by Oak Ridge National Laboratories and available from third parties

Also, in conjunction with Applied Research Associates, we offer our **WIP** perchlorate removal process, using patent-pending regenerable weak base anion resin technology. This technology is ideally suited for elevated levels of perchlorate (e.g. 100 to 1000 ppb and higher). The technology has also been demonstrated to simultaneously remove perchlorate and nitrate and has the capability to remove other oxyanions (e.g. selenate, chromate, molybdate, pertechnetate, perrhenate, etc.).

Our **A532E** and **A530E** bifunctionalized resins, manufactured under license from Oak Ridge National Laboratories (also known as “BiQuat” resins) offer the highest selectivity for perchlorate and pertechnetate.

Services: Purolite provides a full array of services with experienced personnel for handling all resin operations to end users and OEMs.



Purolite Bulk Resin Tanker Delivers Perchlorate Selective Resin to a Site in California

In the USA, we utilize our bulk tankers for fast and efficient unloading and loading of resins. We

contract with approved facilities for disposal of spent resins by incineration and can provide a final certificate to show proper waste resin disposal, using full chain-of-custody controls.

Advantages:

- Low operating cost with simple system design, requiring minimum operator attention.
- Reliable capacity projections available using proprietary simulator software combined with field data.
- Customizable solution for simultaneous removal of other oxyanions.
- Single responsible source, providing full service capability for all resin operations.

Barium / Radium / Strontium Removal

Overview: Radium 226, radium 228 and strontium-90 are radionuclides that are of major concern in many countries and currently regulated in the USA with a combined MCL for radium 226 and radium 228 of 5 picoCuries/liter and a MCL of 8 picoCuries/liter for strontium-90. Barium is regulated by the US EPA at 2 ppm maximum.

Treatment: Although standard strong acid cation (SAC) resins can remove these divalent cations readily from water, the efficiency of standard brine elution is reduced from cycle to cycle due to the slow diffusion of their larger atomic mass deep into the matrix of the resin. The phenomenon is much more noticeable with barium which is usually present in water in ppm concentrations. This can result in a quick buildup of precipitated barium salt within the resin beads in just a few months of operation, with the need to periodically remove the resin from service for specialist chemical cleaning with acid. **Purolite SST60** and **SST80** shell-core strong acid cation resins are superior choices for this type of application due to the inert core of these resins preventing deep fouling of the resin beads. The shorter diffusion path present in such SST resin beads translates to quicker more efficient elution of the cations and reduced fouling rate, resulting in lower overall operating costs.

For optimum performance, we usually recommend counterflow regenerated ion exchange systems with a salt dosage of at least 240 g/l (15 lbs/ft³) and a minimum brine contact time of 60 minutes.

Advantages:

- Inert core of our **Purolite SST60** resin provides unique resistance to fouling.
- **SST60** provide superior elution and lower rinse volumes compared to standard SAC resins.
- In-house design recommendations provided.

Uranium Removal

Overview: Uranium a naturally occurring radionuclide found in both surface and ground water, is a known human carcinogen with a current MCL of 30 ppb. Uranium has an extremely long half life of approximately 4.5 billion years eventually emitting large radioactive alpha particles, which cannot penetrate the skin but can be a significant internal hazard if ingested or inhaled.

Treatment: Uranium usually exists as anionic uranyl carbonate or uranyl sulfate complexes. These complexes are either divalent or tetravalent in ionic charge depending on the system pH. As a result most strong base anion resins show extremely high selectivity for it. Operating capacity is directly impacted by sulfate concentration in the water, with capacities typically ranging from 10,000 to 200,000 bed volumes and even higher. Using our proprietary software we can predict the operating capacity for our various resins based on influent water chemistry.

Recommended **Purolite** products include: **A300E or A200E – Type II Styrenic SBA, A400E and A600E – Type I Styrenic SBAs, and A850 - Type I Acrylic SBA.**

Brine regeneration of uranium loaded resin is a feasible option, using 10% or higher brine concentration and salt dosages ranging from 160 to 240 g/l (10 to 15 lbs/ft³), depending on the specific job requirements.

Another option is to use the resin once and dispose of it. If considering this option, it is important to note that the relevant regulatory requirements for handling and disposal of uranium loaded media for each location must be adhered to.

A handling and transportation license is required in many countries for instance if uranium will exceed a certain weight (0.05% in the USA) on the spent media. In addition, operators must comply with governing regulations on transportation and disposal at facilities approved for storing radionuclide waste.

Advantages:

- Efficient software modeling capability for quick capacity estimates.
- In-house help with design criteria.
- Multi-contaminant design approach as needed for simultaneous removal of other contaminants (see below).

Multi-contaminant Removal – Arsenic / Nitrate / TOC / Uranium

Often, a specific water supply may contain more than one contaminant that must be removed. In such cases, it may be cost effective to simultaneously remove these contaminants, either using a single use or regenerable resin. Since several contaminants discussed above use brine for regeneration, it is quite feasible to design for combined removal of a number of contaminants. For example, nitrate and arsenic or nitrate and uranium co-occur in several locations. We have participated in the design of a number of projects using this multi-contaminant approach, for the removal of nitrate, uranium, arsenic, TOC and perchlorate in co-occurring in various combinations. A similar design approach can be used for removal of cations combined with anions, such as hardness, barium, TOC and uranium. Our in-house capability to model the resin performance in the presence of these multi-contaminants can be used to optimize the final process design and minimize or eliminate the need for field pilot studies.

Advantages:

- Simple ion exchange system that can handle at least 4 contaminant in a single vessel.
- Major reduction in footprint, capital and operating costs.
- Simple to operate plant with single waste volume to handle.

Membrane Protection Resins – MPR and SST60 Technologies

The widespread use of reverse osmosis membrane technologies for remediation of ground water presents an opportunity to apply our proprietary resin based technology to protect the sensitive RO membranes from fouling and resulting loss in efficiency.

Our **Purolite MPR1000** is a brine regenerable proprietary mix of resins that can typically reduce SDI by greater than 40% and TOC by 50% to 80%, thus reducing power and membrane cleaning costs while increasing overall recovery and system reliability.

With use of our proprietary **SST60** shell and inert core type SAC resin to remove divalent cations such as



Simultaneous Removal of Arsenic, Nitrate, TOC and Uranium at City of McCook Using Brine Regenerable Resins

type SAC resin to remove divalent cations such as barium, hardness and iron from the feed, permeate water recovery rates up to 90% to 95%, and even higher are possible. This is of special interest to arid regions where disposal options for RO concentrate are limited and where water supplies are scarce.

Further, the special shell and inert core nature of this resin allows cost-effective regeneration with just the reject brine from the RO, using our Cyclic Ion Exchange (CIX) process. The shorter diffusion path of SST resins, compared to standard SAC resins, results in much greater elution efficiency for divalent cations. Relatively low RO reject brine concentrations (0.5%) can be used. Fouling by barium and strontium, typical with the core of standard SAC beads, is eliminated because of the inert core of this resin.

By using this “natural free regenerant” approach, our Cyclic Ion Exchange Process (see below) eliminates the additional environmental burden from using commercial regenerants while maximizing the use of scarce water resources.

Advantages:

- **MPR1000** offers unique solution to the membrane industry to improve operating efficiency.
- Potential to design smaller membrane plants for same job.
- CIX process provides a “green technology” approach with minimal environmental impact.

- Potential to significantly increase membrane recovery rates and conserve scarce water resources.

Cyclic Ion Exchange Process

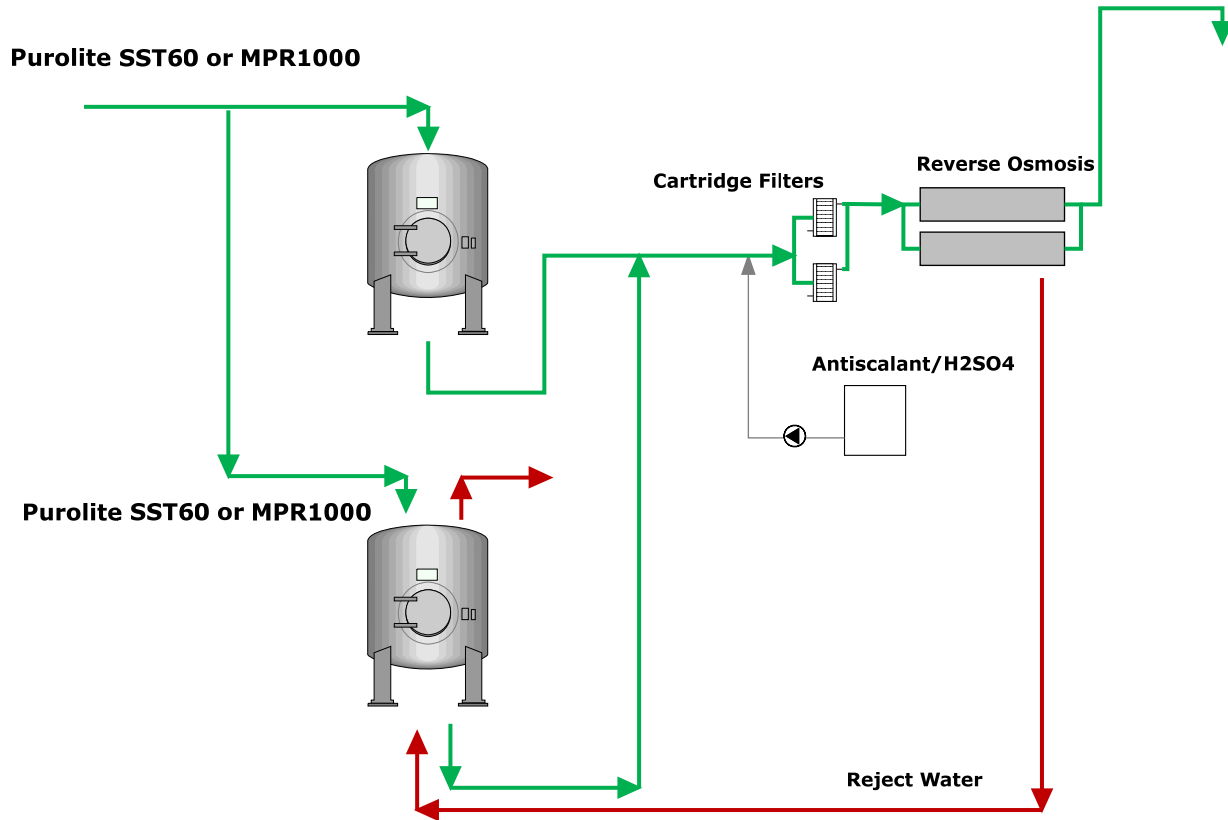

Please contact us for help in optimizing the design for any of the above treatment approaches.

Additional information is available on our web site at

LENNTECH

info@lenntech.com

www.lenntech.com

Tel. +31-15-261.09.00

Fax. +31-15-261.62.89

LENNTECH

info@lenntech.com

www.lenntech.com

Tel. +31-15-261.09.00

Fax. +31-15-261.62.89

Just ask Purolite.

PUROLITE[®]
ION EXCHANGE RESINS