

NOCCHI CPS 10 ELECTRONIC FREQUENCY CONVERTER

EASY TO INSTALL, LOW ENERGY CONSUMPTION, COMPACT SIZE

CPS is an electronic device designed to vary the frequency of an electric pump. It is incorporated directly on the motor to enable control of the speed to provide the utility with a constant pressure even in the event of changes in water demands. CPS offers a compact, essential, reliable and practical solution, also designed to ensure the utmost comfort and benefits when applied in the sectors of irrigation, greenhouses, light industry, fountains and water features.

The system comprises an electric pump and electronic control system (inverter) to ensure that pressure is kept constant in the system, reducing or increasing the speed of motor rotation on the electric pump as required. When the system pressure falls below the set threshold, the module starts

up the pump to restore the set point pressure; the pump rotation speed varies according to water demand and therefore increases speed on requests for increased quantities, through to the maximum setting. On decrease in water demand, the pump speed is decreased through to the minimum setting, after which, if no further decreases in pressure occur (i.e. new water demands) the pump is stopped on standby until a new cycle starts.



APPLICATIONS

- Pressure booster systems
- Water supply
- Industry
- Construction
- Washing

PROTECTION DEVICES

- Dry-running
- Current overload
- Electronics overheating
- Anti-freeze via external device

TECHNICAL SPECIFICATIONS

- Power supply voltage: inverter 1x230 Vac \pm 10 %.
- Inverter output voltage: 3x230 Vac \pm 10 %
- Maximum nominal power: 1.5 Kw
- Input frequency: 50/60 Hz + 3%
- Maximum nominal output current: 6.5 Amp
- Protection rating IP55 (if installed on motors with protection rating of IP55 or higher)
- Ambient temperature from +0°C to +40°C
- Waveform: sinusoidal
- Inlet filter compliant with EMC directive
- Pressure transducer 0 - 5 Volt - 0 - 10 Bar
- Set-point 2
- Interface connectivity: RS 485 serial port
- 3 optional contacts (external set-point, alarm, system disable)

NOCCHI CPS 10

ELECTRONIC FREQUENCY CONVERTER

VERSIONS AVAILABLE

VERTICAL	HORIZONTAL	SELF-PRIMING
CPS10/VLR 2B-60 A	CPS10/MULTINOX-VE 200/80	CPS10/MULTINOX-XC 120/45
CPS10/VLR 2B-110 A	CPS10/DHI 4-50	CPS10/MULTINOX-XC 120/60
CPS10/VLR 4-80 A	CPS10/DHI 2-70	CPS10/JET 1000
CPS10/VLR 8-40 A	CPS10/DHR 4-50	CPS10/MULTINOX-A 200/40
CPS10/VLR 4-100 A	CPS10/DHR 9-40	CPS10/MULTINOX-A 200/65
CPS10/MULTINOX-VE 200/65	CPS10/DHR 9-60	CPS10/MULTINOX-A 200/80
CPS10/MULTINOX-VE 200/40	CPS10/MULTINOX-XC 80/48	

CONTROL PANEL

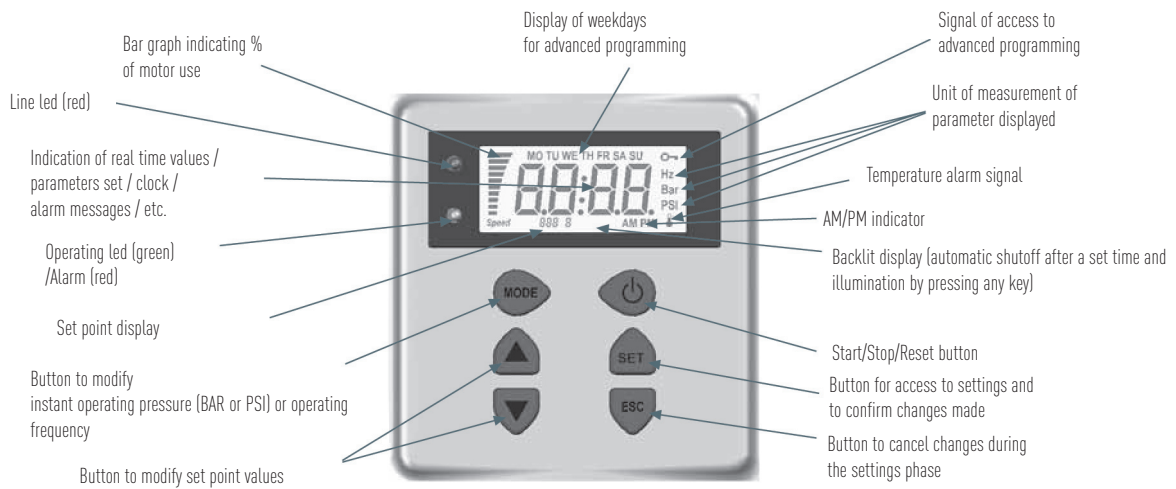

NOCCHI CPS10/JET

ELECTRONIC FREQUENCY CONVERTER

HYDRAULIC PERFORMANCE

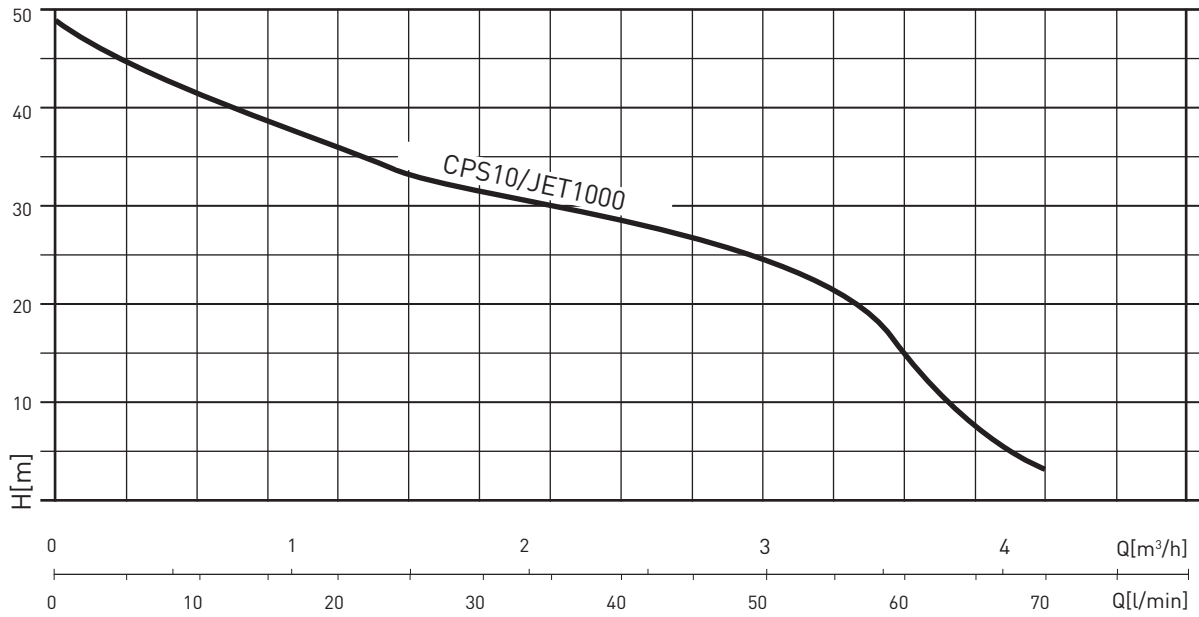

PERFORMANCE TABLE

MODEL	P2		Volt	In (A)	Q	L/min	0	5	20	30	40	50	60	70
	HP	kW				m³/h	0	0.3	1.2	1.8	2.4	3	3.6	4.2
CPS10/JET 1000	1.36	1	1 - 230	6.5	m.c.a./ m.w.c.	49	45	36	32	28	25	15	15	3

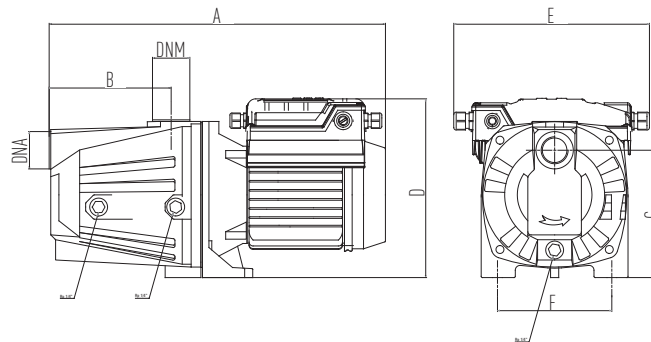

OVERALL DIMENSIONS AND WEIGHTS

MODEL	Dimensions (mm)							Weight kg
	A	B	C	D	E	DNA	DNM	
CPS10/JET 1000	400	147	160	260	195	1"	1"	20.8

NOCCHI CPS10/MULTINOX XC

ELECTRONIC FREQUENCY CONVERTER

HYDRAULIC PERFORMANCE

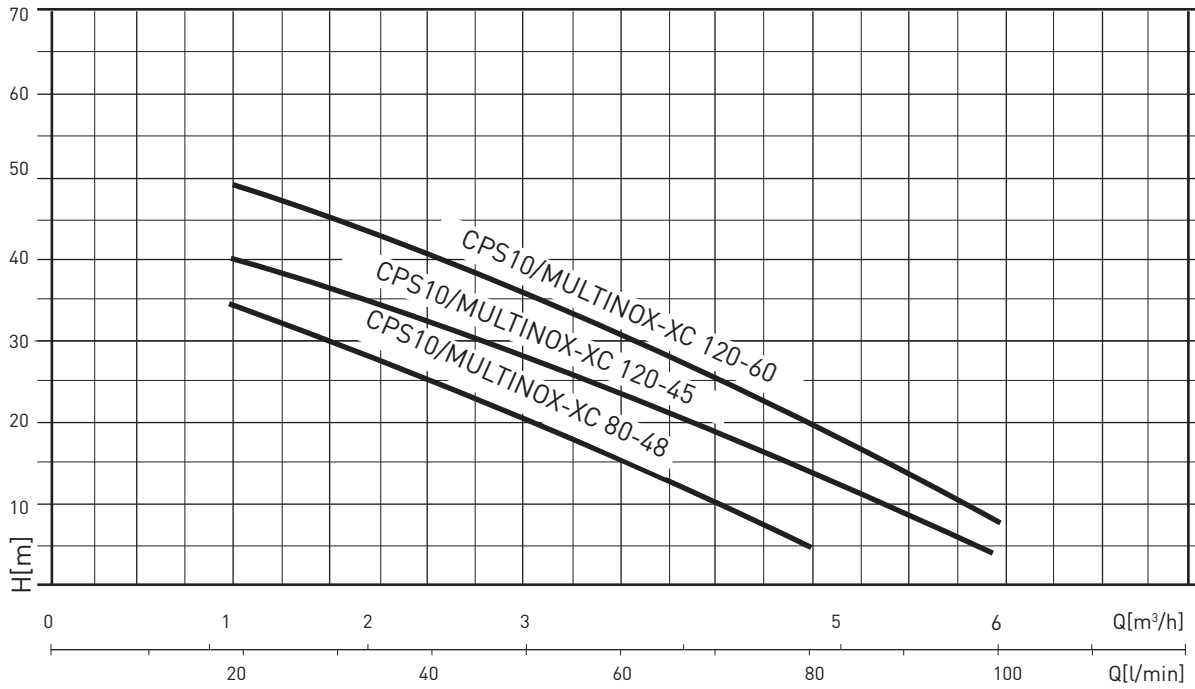

PERFORMANCE TABLE

MODEL	P2		Volt	In (A)	Q	L/min					
	HP	kW				0	20	40	60	80	100
CPS10/MULTINOX-XC 80/48	0.75	0.55	1 - 230	5.1	m.c.a./m.w.c.	0	1.2	2.4	3.6	4.8	6
CPS10/MULTINOX-XC 120/45	1.1	0.85	1 - 230	8.1		40	34	25	15	4	
CPS10/MULTINOX-XC 120/60	1.2	0.9	1 - 230	8		46	40	33	24	14	3
						55	49	42	32	20	7

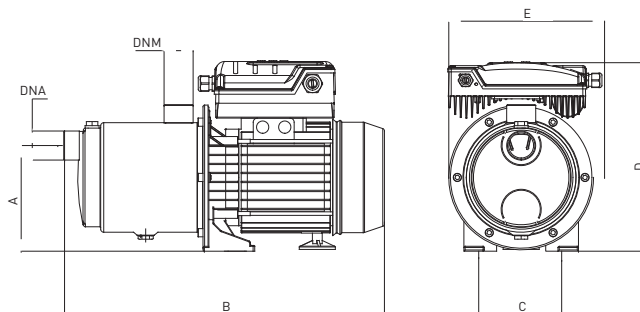

OVERALL DIMENSIONS AND WEIGHTS

MODEL	Dimensions (mm)							Weight kg
	A	B	C	D	E	DNA	DNM	
CPS10/MULTINOX-XC 80/48	129	348	99	215	250	1"	1"	9.5
CPS10/MULTINOX-XC 120/45	129	370	99	215	250	1"	1"	11.5
CPS10/MULTINOX-XC 120/60	129	392	99	215	250	1"	1"	12.5

NOCCHI CPS10/MULTINOX-A

ELECTRONIC FREQUENCY CONVERTER

HYDRAULIC PERFORMANCE

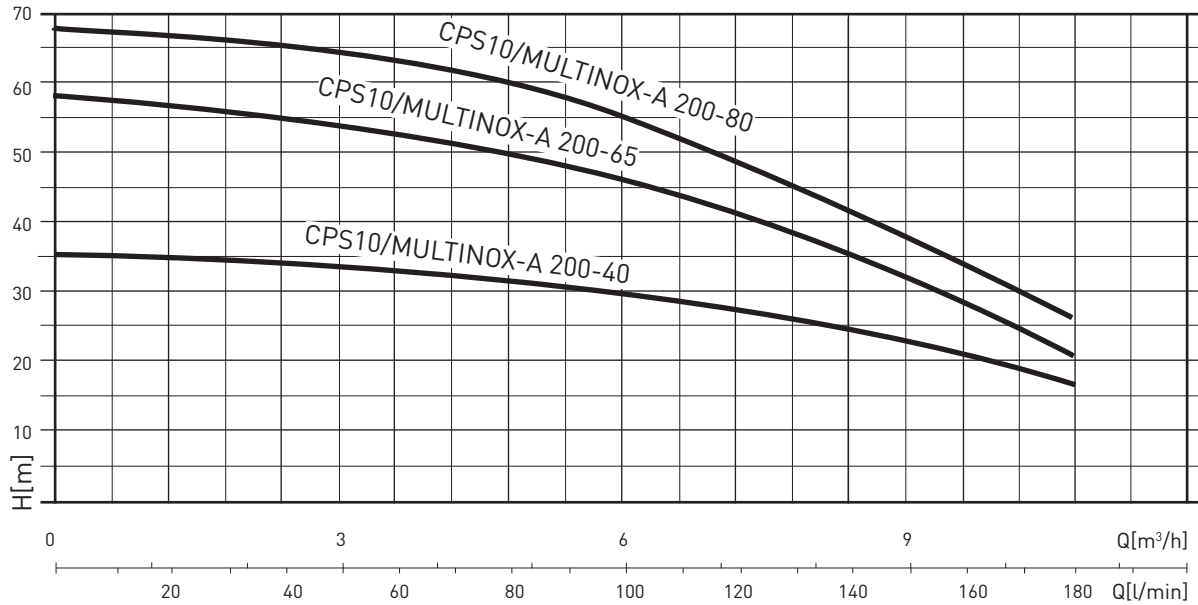

PERFORMANCE TABLE

MODEL	P2		Volt	In (A)	Q	L/min	0	20	60	100	140	180
	HP	kW				m³/h	0	1.2	3.6	6	8.4	10.8
CPS10/MULTINOX - A 200/40	1.5	1.1	1 ~ 230	8.7	m.c.a./m.w.c.	35	33.7	32.1	27.6	21.5	13.1	
CPS10/MULTINOX - A 200/65	1.9	1.4	1 ~ 230	14.4		58	56.1	53.4	46	35.8	21.8	
CPS10/MULTINOX - A 200/80	2.5	1.75	1 ~ 230	15.5		68	67.3	64.1	55.2	42.9	26.2	

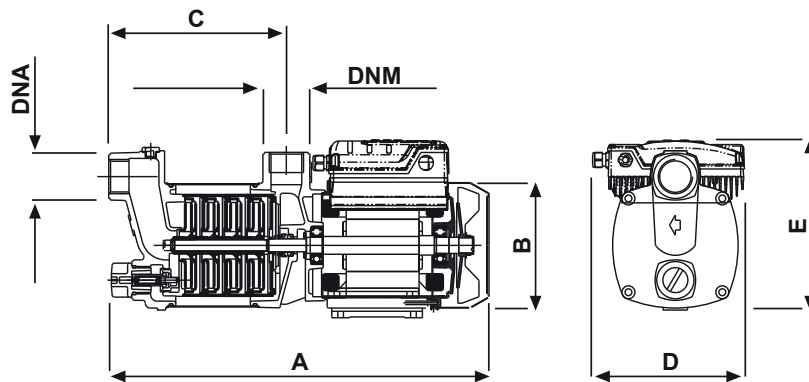

OVERALL DIMENSIONS AND WEIGHTS

MODEL	Dimensions (mm)							Weight kg
	A	B	C	D	E	DNA	DNM	
CPS10/MULTINOX - A 200/40	441	170	188	232	225	1" 1/4	1" 1/4	21.2
CPS10/MULTINOX - A 200/65	497	170	243	232	225	1" 1/4	1" 1/4	24
CPS10/MULTINOX - A 200/80	525	170	270	232	245	1" 1/4	1" 1/4	26

NOCCHI CPS10/MULTINOX-VE

ELECTRONIC FREQUENCY CONVERTER



HYDRAULIC PERFORMANCE

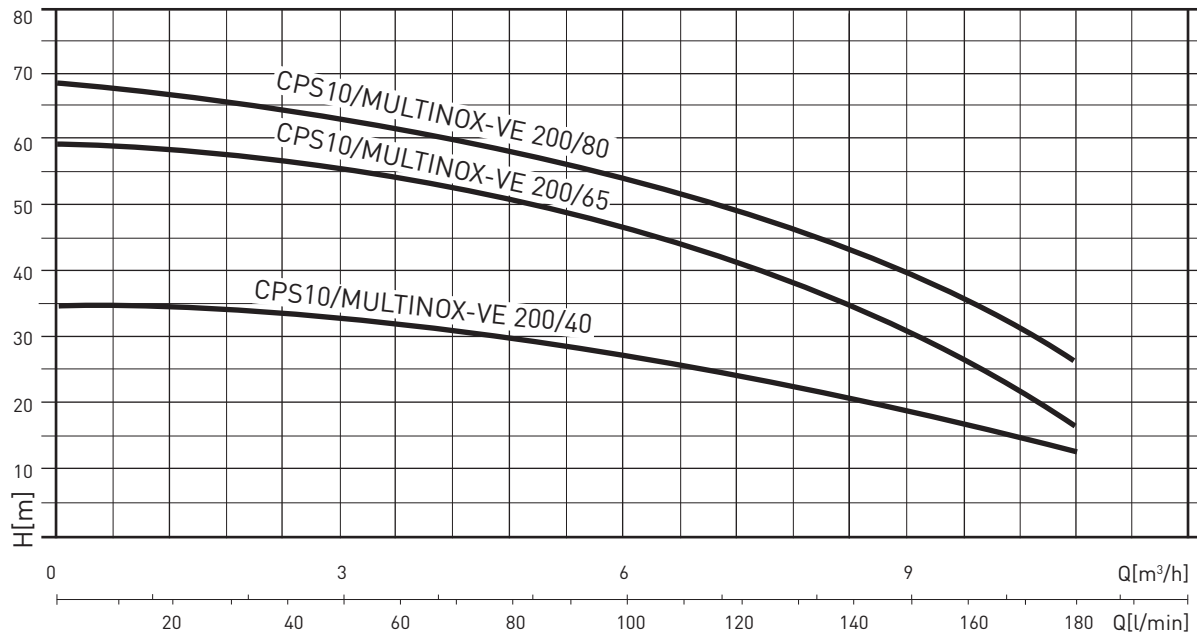

MEI ≥ 0.1 - MEI reference ≥ 0.70 - The reference efficiency information is available on the website: www.europump.org/efficiencycharts

For efficiency characteristics see MULTINOX-VE models

PERFORMANCE TABLE

MODEL	P2		Volt	In (A)	Q	L/ min	0	20	60	100	140	180
	HP	kW				m³/h	0	1.2	3.6	6	8.4	10.8
CPS10/MULTINOX-VE 200/40	1.5	1.1	1 ~ 230	8.7	m.c.a./m.w.c.	35	33.7	32.1	27.6	21.5	13.1	
CPS10/MULTINOX-VE 200/65	1.9	1.4	1 ~ 230	14.4		58	56.1	53.4	46	35.8	21.8	
CPS10/MULTINOX-VE 200/80	2.5	1.75	1 ~ 230	15.5		68	67.3	64.1	55.2	42.9	26.2	

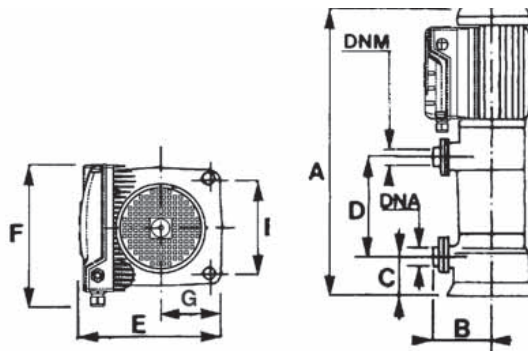

OVERALL DIMENSIONS AND WEIGHTS

MODEL	Dimensions (mm)										Weight kg
	A	B	C	D	E	F	G	I	DNA	DNM	
CPS10/MULTINOX-VE 200/40	438	115	37	143	232	220	72.5	145	1" 1/4	1" 1/4	21.2
CPS10/MULTINOX-VE 200/65	504	115	37	203	232	220	72.5	145	1" 1/4	1" 1/4	25.1
CPS10/MULTINOX-VE 200/80	525	115	37	230	232	220	72.5	145	1" 1/4	1" 1/4	27

NOCCHI CPS10/DHR

ELECTRONIC FREQUENCY CONVERTER

HYDRAULIC PERFORMANCE

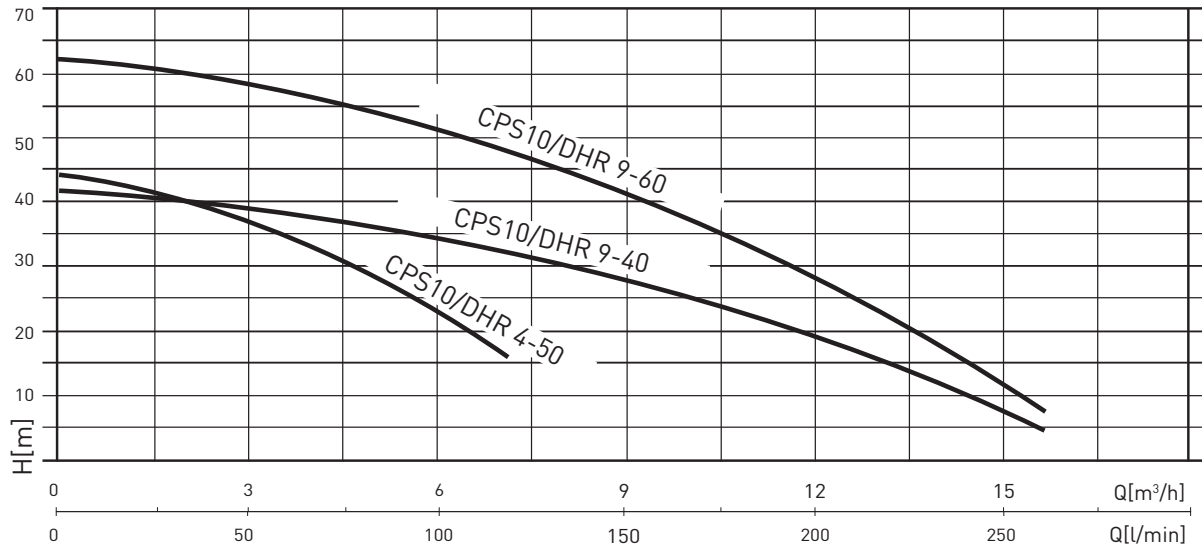

PERFORMANCE TABLE

MODEL	P2		Volt	In (A)	Q	L/min	0	40	60	80	100	120	160	200	240	260
	HP	kW					m³/h	0	2.4	3.6	4.8	6	7.2	9.6	12	14.4
CPS10/DHR 4-50	1.5	0.9	1 - 230	9.1	m.c.a./m.w.c.	44	39	35	30	24	17					
CPS10/DHR 9-40	1.74	1.3	1 - 230	12.5		41.5	40	39	38	35	33	27	19	10	5	
CPS10/DHR 9-60	2.4	1.8	1 - 230	15.8		62	60	58	56	52	49	40	29	14	6	

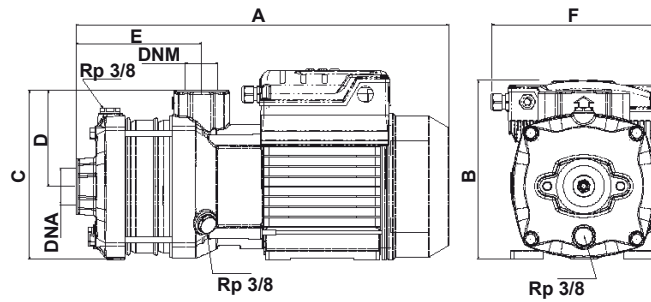

OVERALL DIMENSIONS AND WEIGHTS

MODEL	Dimensions (mm)								Weight kg
	A	B	C	D	E	F	DNA	DNM	
CPS10/DHR 4-50	445	225	155	65	190	232	1" 1/4	1"	18
CPS10/DHR 9-40	408	215	185	105	137	232	1" 1/4	1" 1/4	21.1
CPS10/DHR 9-60	468	215	185	105	198	232	1" 1/2	1" 1/4	26

NOCCHI CPS10/DHI

ELECTRONIC FREQUENCY CONVERTER

HYDRAULIC PERFORMANCE

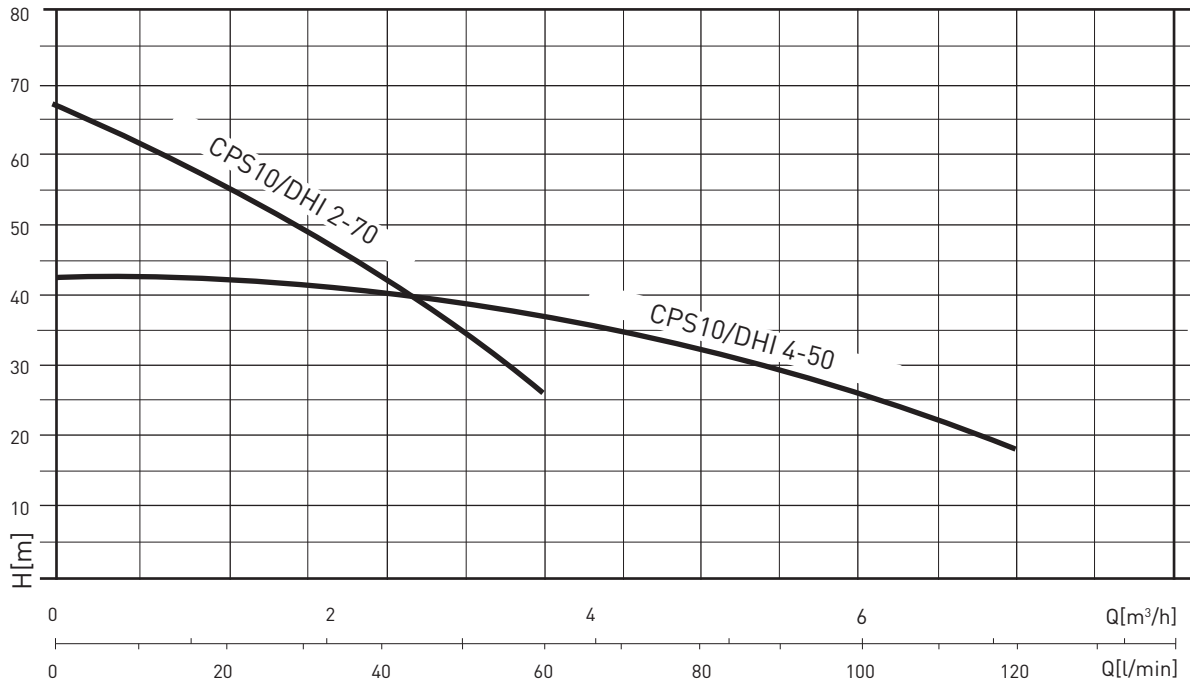

PERFORMANCE TABLE

MODEL	P2		Volt	In (A)	Q	L/min	0	10	20	30	40	50	60	80	100	120
	HP	kW				m³/h	0	0.6	1.2	1.8	2.4	3	3.6	4.8	6	7.2
CPS10/DHI 2-70	1.25	0.9	1 ~ 230	10.6	m.c.a./ m.w.c.	68	63	57	50	43	35	26				
CPS10/DHI 4-50	1.25	0.9	1 ~ 230	10.6		43				42	39	36	33	27	18	

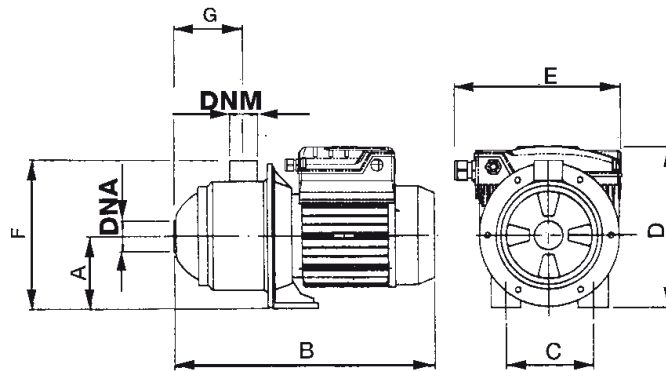

OVERALL DIMENSIONS AND WEIGHTS

MODEL	Dimensions (mm)									Weight kg
	A	B	C	D	E	F	G	DNA	DNM	
CPS10/DHI 2-70	105	460	141	245	232	235	135	1" 1/4	1" 1/4	17.4
CPS10/DHI 4-50	105	460	141	245	232	235	135	1" 1/4	1" 1/4	17.4

NOCCHI CPS10/VLR

ELECTRONIC FREQUENCY CONVERTER



HYDRAULIC PERFORMANCE

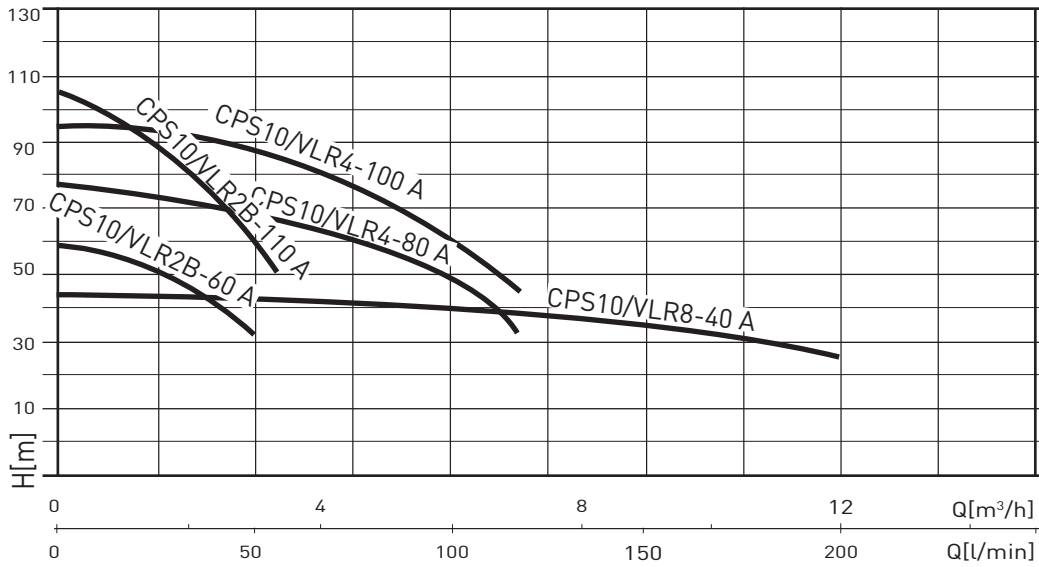

MEI ≥ 0.1 - MEI reference ≥ 0.70 - The reference efficiency information is available on the website: www.europump.org/efficiencycharts
For efficiency data, see electric pump series VLR

PERFORMANCE TABLE

MODEL	P2		Volt	In (A)	Q	L/min																
	HP	kW				0	10	20	30	40	50	60	80	100	120	150	175	200				
						0	0.6	1.2	1.8	2.4	3	3.6	4.8	6	7.2	10	10.5	12				
CPS10/VLR 2B-60 A	1	0.75	1 ~ 230	5.9	n.c.a./m.w.c.	58	56	51	48	42	33											
CPS10/VLR 2B-110 A	1.5	1.1	1 ~ 230	10.2		105	100	93	84	74	60											
CPS10/VLR 4-80 A	2	1.5	1 ~ 230	13.7		77				71	69	67	59	50	37							
CPS10/VLR 4-100 A	3	1.75	1 ~ 230	14.7		94				89	86	82	73	61	44							
CPS10/VLR 8-40 A	2	1.5	1 ~ 230	13.7		44					42	41	41	40	38	35	30	26				

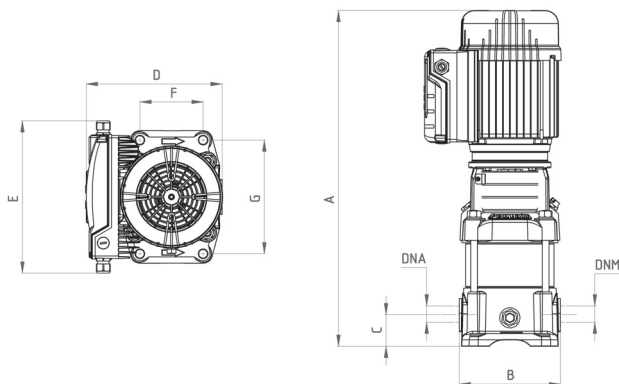

OVERALL DIMENSIONS AND WEIGHTS

MODEL	Dimensions (mm)							Weight kg
	A	B	C	D	E	F	G	
CPS10/VLR 2B-60 A	533	160	50	135	232	100	180	28
CPS10/VLR 2B-110 A	623	160	50	135	232	100	180	38
CPS10/VLR 4-80 A	688	160	50	155	232	100	180	35
CPS10/VLR 4-100 A	742	160	50	155	232	100	180	38
CPS10/VLR 8-40 A	685	200	80	155	232	130	215	42