

3M Purification

Life Sciences Process Technologies

LENNTECH

info@lennotech.com Tel. +31-152-610-900

www.lennotech.com Fax. +31-152-616-289



# LifeASSURE™ PDA

Series Capsules & Cartridges

Sterilising-grade polyethersulfone membrane filters

- ☑ New name for CUNO BioASSURE capsules and cartridges
- ☑ Filter capsules available in *gamma*-compatible and sterile formats
- ☑ Robust sterilising-grade PES (polyethersulfone) membrane
- ☑ Optimised for both superior throughput and superior flow for improved processing
- ☑ Easy to use cartridge and disposable capsule configurations
- ☑ Easy to wet for reliable integrity testing

3M



### LifeASSURE PDA sterilising-grade filter cartridges and capsules

3M Purification's LifeASSURE™ PDA filter, formerly known as CUNO BioASSURE, combines two asymmetric polyethersulfone (PES) membrane layers with the Advanced Pleat Technology design. This combination results in a robust filter that is optimised for both high throughput and fast flow applications while offering 0.2 µm absolute-rated filtration for sterilising performance. The hydrophilic polyethersulfone membrane wets easily for integrity testing and is ideal for applications where low protein binding is critical.

### LifeASSURE PDA Series membrane technology

LifeASSURE PDA filters incorporate two layers of polyethersulfone membrane. The upstream layer (figure 1) is highly asymmetric and provides optimised prefiltration capacity for the downstream layer (figure 2) that contains a robust, centrally located, retention zone. Both membrane layers are asymmetric and together result in a filter with multiple filtration zones providing extremely high contaminant capacity, fast flow rates and reliable sterilising filtration performance.

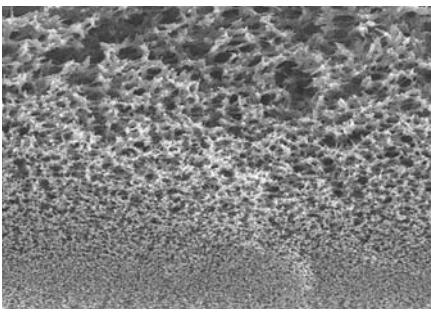

Figure 1: LifeASSURE™ PDA upstream layer

### Advanced Pleat Technology construction

LifeASSURE PDA filters also feature the Advanced Pleat Technology design for extended service life. This design technology maximises the useful surface area of the filter while maintaining open flow paths between media pleats (figure 3). By employing the Advanced Pleat Technology design, the LifeASSURE PDA filter provides lower pressure drops, longer service life and lower overall filtration costs.

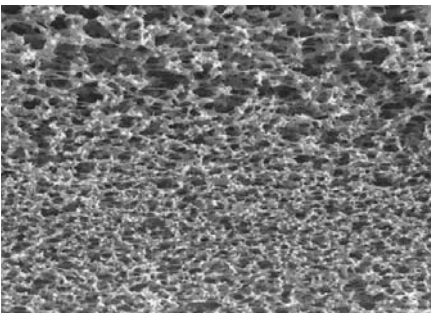

Figure 2: LifeASSURE™ PDA downstream layer

## Features and benefits

#### Robust double membrane layer filter construction

- Exceptionally high contaminant capacity and fast flow rates for long on-stream life and maximum economy

#### Hydrophilic asymmetric polyethersulfone membrane

- Ensures easy wet-out for integrity testing and low protein binding

#### Validated 0.2 µm absolute-rated membrane

- Reliable sterilising filtration

#### Filter capsules are available in both *gamma*-compatible and sterile formats

- Eliminates cleaning and cleaning validation step associated with stainless steel housings for maximal ease-of-use

#### Advanced Pleat Technology construction

- Allows maximum fluid and contaminant access to filter surface area for highest throughput

#### 100% Integrity tested prior to release

- Ensures consistent performance to specification

#### 21 CFR materials of construction, USP Biological Safety Test for Plastics - Class VI, Validation Guide and Drug Master File (DMF)

- Eases validation and regulatory submissions

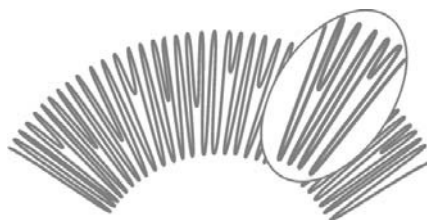

Figure 3: Advanced Pleat Technology design

### Meeting scale-up requirements

A full range of LifeASSURE PDA sterilising-grade filters is available to meet your scale-up process needs. This range includes disposable capsules, mini-cartridges and full-size cartridges. In addition, LifeASSURE PDA filter discs are available when even smaller membrane surface areas are required.

## Applications

LifeASSURE™ PDA filters are optimised for applications requiring critical sterilisation where 0.2 µm absolute-rated filtration is required.

- Biologicals
- Orals and topicals
- Vaccines
- Parenterals (SVP, LVP)
- Ophthalmics
- Final 0.2 µm sterilising filtration
- Chromatography column protection
- Serum and blood fractions
- Solvent filtration
- Bulk pharmaceutical chemicals
- Media and fermenter feed streams
- Cell culture fluids
- High protein feed streams
- Reagents and Buffers
- High purity DI water and WFI systems

## Superior performance

The charts below show the superior performance of the LifeASSURE PDA filters in a variety of targeted applications.

The results show both the high flow rate and high throughput capacity of the LifeASSURE PDA filters compared to other PES membrane filters.

Also shown are comparisons of LifeASSURE PDA filters to PES, PVDF and nylon membrane filters in adsorption related tests. These results show that LifeASSURE PDA filters are low protein and preservative binding, consistent with polyethersulfone membranes.

### Water flow

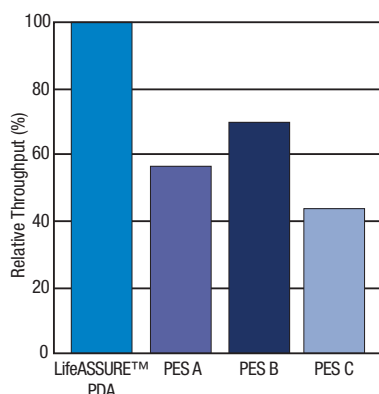

Relative water flow of 10-inch LifeASSURE™ PDA and commercially available PES cartridge filters. PES A, B, C cartridges water flows from product literature.

### Bovine IgG

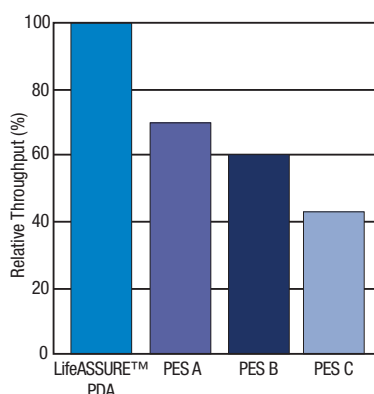

Relative throughput of bovine IgG (50 mg/ml) with equal area polyethersulfone membrane. Relative filtrate volume after 10 minutes at 1.1 bar feed pressure was measured.

### CHO cell media

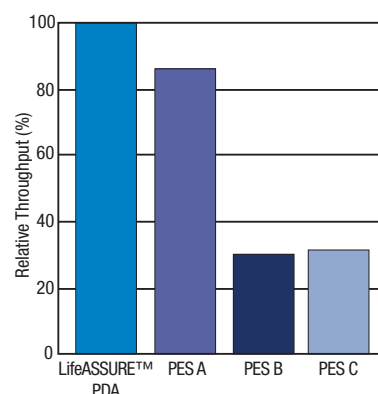

Relative throughput of CHO cell media feed with equal area polyethersulfone membrane. Tests were conducted at a constant flow and throughput volume was measured at a terminal pressure of 1.75 bar.

### CHO cell biomass

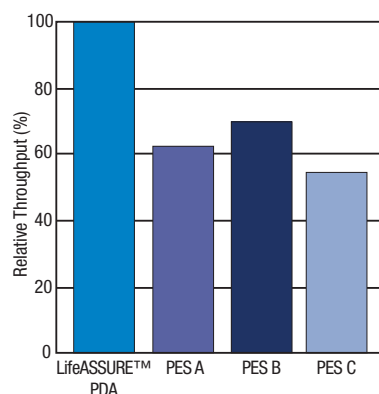

Relative throughput of CHO cell biomass with equal area polyethersulfone membrane. Relative throughput volume after 10 minutes at 0.7 bar feed pressure was measured.

### Protein adsorption

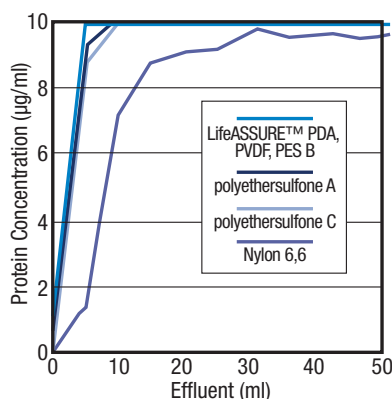

Equal area membranes were evaluated for protein adsorption using bovine serum albumin at an inlet concentration of 10 µg/ml. All of the membranes tested - with the exception of Nylon 6,6 - showed comparable, rapid saturation to baseline performance.

### Preservative adsorption

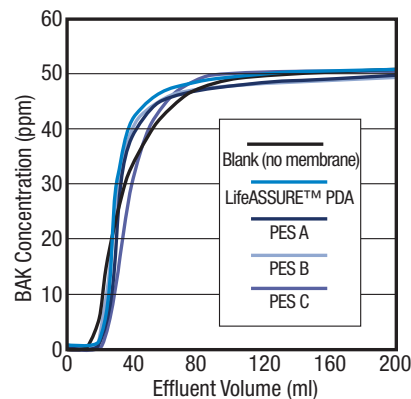

Equal area membranes were evaluated for adsorption of a commonly used ophthalmic preservative, benzalkonium chloride-BAK at an inlet concentration of 50 ppm. The results show all of the membranes tested had similar saturation profiles.

## Optimised for use with 3M prefilter cartridge and filter capsules

LifeASSURE PDA sterilising-grade filters are designed for use with 3M prefilters. There are three prefilter types referenced in table 1 below.

Prefilter type	Material of construction	Typical applications
LifeASSURE™ PNA Series filters	polyethersulfone	Buffers, media feeds
Zeta Plus™ EXT Series filters	cellulose depth filter	Cell culture debris clarification, concentrated protein feeds, serum, difficult to filter biological fluids

## Robust filtration performance

In order to measure design robustness, sample LifeASSURE PDA filters were subjected to multiple *in situ* steam sterilisation cycles or exposure to aggressive acid and alkaline fluids. Table 2 shows the results of these studies. Thermal cycling represents a severe test of structural integrity due to the elevated temperature exposure and expansion and contraction of filter components. Caustic compatibility is a desirable feature for chromatography column protection where caustic fluids used for column sanitisation and regeneration can be passed directly through LifeASSURE PDA filters. Compatibility with acids provides filtration performance with aggressive buffers, column regeneration fluids and CIP protocols.

Test	Exposure condition	Post exposure integrity test result
<i>In situ</i> steam cycle (cartridges only)	20 cycles of 30 minutes at 135 °C	Pass
1 M sodium hydroxide	10 cycles of 60 minutes at 60 °C	Pass
1 M acetic acid	10 cycles of 60 minutes at 25 °C	Pass
1 M hydrochloric acid	10 cycles of 60 minutes at 25 °C	Pass

## Performance engineered cartridge design

All-polypropylene structural components (end caps, adapters, media support, inner core and outer cage) used in the device fabrication ensure exceptional thermal and mechanical stability, broad chemical compatibility and low extractable levels. LifeASSURE PDA filter cartridges are available in 2.5", 5", 10", 20", 30" and 40" lengths to match the dimension and sealing requirements of most currently available cartridge housings.

## Mini-cartridges

For critical small volume applications, LifeASSURE PDA filters are available in 2.5" and 5" mini-cartridges. Installed in a 3M 2.5" or 5" mini-cartridge housing or in existing competitor housings, LifeASSURE PDA mini-cartridges offer low hold-up volume and economical small volume filtration.

## Disposable *Gamma*-Compatible and Sterile filter capsules

For critical applications where convenience and ease of use are desired, LifeASSURE PDA filters are available in 2.5", 5", 10", 20" and 30" disposable capsules. The capsules are supplied with sanitary vent and drain ports as well as 1 1/2" sanitary flange connections. The 2.5" and 5" mini-capsules are available with your choice of 1/2" (13 mm) hose barb inlet/outlet connections or 1.5" sanitary flange connections. The capsules eliminate the steps associated with assembling, cleaning and validating stainless steel housings, thus providing maximal ease-of-use and significant cost saving. All capsules are available in both *gamma*-compatible and sterile formats. *Gamma*-compatible capsules are compatible with autoclaving or *gamma*-irradiation up to 45 KGy. Sterile filter capsules are ready for use without further sterilisation.



LifeASSURE PDA specifications

	Cartridges		Mini-cartridges		Capsules				
	5 to 40"	2.5" length	5" length	2.5"	5"	10"	20"	30"	
Filter rating	0.2 µm								
<b>Materials of construction</b>									
Cage, core, end caps and adaptors	polypropylene								
Membrane	polyethersulfone								
Membrane support layer	polypropylene								
Encapsulated adapter reinforcing ring	polysulfone	N/A		N/A					
	Cartridges		Mini-cartridges		Capsules				
Filtration surface area (m <sup>2</sup> )	5": 0.35 10": 0.78*	0.12	0.26	0.12	0.26	0.78	1.56	2.35	
Typical water flow rate at 25 °C and 0.07 bar in lpm	5": 8.8 10": 19.8 20": 35.7 30": 49.4 40": 49.4	2.7	6.6	2.7	6.6	19.8	35.7	49.4	
	Cartridges		Mini-cartridges		Capsules				
	5 to 40"	2.5" length	5" length	2.5"	5"	10"	20"	30"	
<b>Operating parameters</b>									
Maximum operation temperature	80 °C				40 °C				
Maximum differential pressure in bar	Forward pressure: 5.5 at 25 °C ; 1.7 at 80 °C Reverse pressure: 2.4 at 25 °C				4.5 at 40 °C				
<i>In situ</i> steam conditions	Up to 135 °C (10 cycles, 30 minutes each)				Do not <i>in situ</i> steam				
Autoclave conditions	Up to 126 °C (20 cycles, 30 minutes each)								
<i>Gamma</i> sterilisation	<i>Gamma</i> -Compatible: N/A Sterile: N/A				Up to 45 KGy Do not resterilise				
Sterility (Sterile)	N/A				Meets current AAMI guidelines for sterility utilising a validated sterilisation cycle. DO NOT resterilise.				
	Cartridges		Mini-cartridges		Capsules				
Integrity test parameters (water wet at 25 °C)	5 to 30"	2.5"	5"	2.5"	5"	10"	20"	30"	
Diffusional flow, cc/min at 2.75 bar (Contact 3M Purification for multiple assemblies)	5": 17.2 10": 38 20": 71 30": 104	6.7	15	6.7	15	38	71	104	
Minimum bubble point	3.10 bar								

Standard cartridge

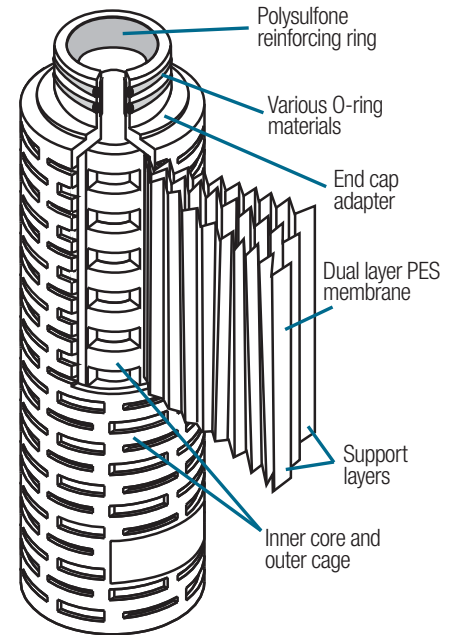

Mini-cartridge

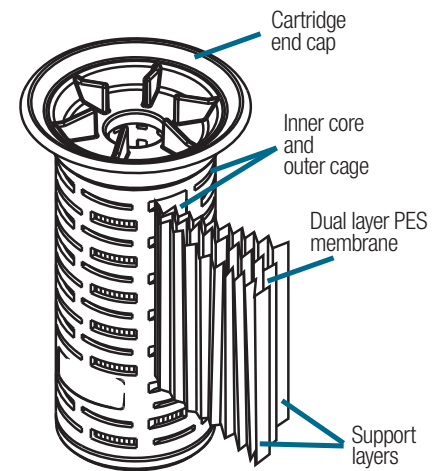

Capsule

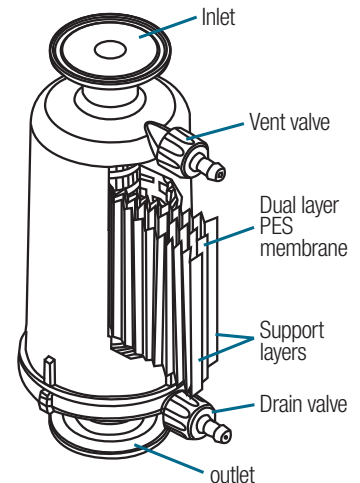

\* For multiple cartridge lengths, multiply by number of 10" equivalent lengths.



## Filter housings

A specialised range of filter housings is available to meet the needs of the pharmaceutical, biological and bioprocess industries. They provide easy access for filter change-out and the greatest assurance that LifeASSURE PDA filter cartridges are sealed securely, thus eliminating the possibility of fluid bypass. All housings are constructed using 316L stainless steel to maximise corrosion resistance. Internal surfaces of the housings are polished to Ra 0.8 µm to limit microbial adhesion and provide for easy cleaning.

Housing model	IPW	ZWB	ZS
Cartridge capacity	1 to 8 round 1, 2, 3 and 4 high	1 to 27 round 1, 2, 3 and 4 high	Single cartridge, 2.5", 5" 1, 2, 3 and 4 high
Housing style	Sanitary "T"-Line		
	CoreLine	Specials - make to order	
Materials of construction	1.4404 / 316L stainless steel	316L (1.4404) as default. Other alloys available - C22 "Hastelloy", Low ferrite (<1%, <3%) (details upon request).	
Pressure ratings	10 bar g	As required by application	
Temperature ratings	150 °C	As required by application	
PED 97/23/CE	I	As required by application - Up to Cat IV	
ATEX 94/9/CE	II-2-G/D-T5	As required by application - up to II-2-G/D-T5	
Other details		Fully customisable - including heating jackets, CIP/ SIP etc.	



## Quality and Reliability

LifeASSURE PDA filters are manufactured in accordance with the ISO Quality Management System and are 100% integrity tested prior to shipment. All materials of construction are 21 CFR listed and cartridge and capsule filter components have been tested in accordance with United States Pharmacopoeia (USP) Biological Safety test for Plastics - Class VI. All LifeASSURE PDA cartridge and capsule filters are shipped with a Certificate of Quality affirming compliance with rigid manufacturing quality specifications. Supporting Drug Master File (DMF) documentation is on file with the United States Food and Drug Administration (FDA). A complete LifeASSURE PDA Validation Guide is available upon request.

## Validation support services

3M Purification offers specialised support to the pharmaceutical and biotechnology industry through our Scientific Applications Support Services (SASS) group. SASS routinely provides end-users with:

- Validation and regulatory support
- Extractable and compatibility analysis
- Filter system optimisation studies.

For more information regarding 3M Purification's validation support services, please contact 3M Purification Technical Services.

### LifeASSURE™ PDA cartridges - Ordering guide

Grade designation	Configuration	Height (inches)	End modification	O-ring material
PDA 020 - 0.2 µm	F	50 - 5 01 - 10 02 - 20 03 - 30 04 - 40	B - 226 O-ring & spear C - 222 O-ring & spear F - 222 O-ring & flat cap J - 226 O-ring & flat cap	A - silicone (MVQ)* B - fluorocarbon (FPM)* C - EPR (EPDM)* D - nitrile (NBR)* K - PTFE-encapsulated fluorocarbon

\*ISO Designation

### LifeASSURE™ PDA mini-cartridges - Ordering guide

Grade designation	Configuration	Height (inches)	End modification	Package quantity
PDA 020 - 0.2 µm	M	01 - 2.5 02 - 5	AN- Flange seal	01 - 1-Pack

### LifeASSURE™ PDA capsules - Ordering guide

Grade designation	Configuration	Height (inches)	End modification	Vent O-ring option	Sterilisation	Package quantity
PDA 020 - 0.2 µm	C - Small Capsules	01 - 2.5 02 - 5	A - 1 ½" sanitary fitting B - 13 mm hose barb	A - silicone	G - Gamma-compatible S - Sterile	N1 - 1-Pack
	J - Large Capsules	01 - 10 02 - 20 03 - 30	A - 1 ½" sanitary fitting			

All units are packaged one per box.

**NOTE:** LifeASSURE PDA is new name for CUNO BioASSURE.



#### Important Notice

The information described in this literature is accurate to the best of our knowledge. A variety of factors, however, can affect the performance of the Product(s) in a particular application, some of which are uniquely within your knowledge and control. INFORMATION IS SUPPLIED UPON THE CONDITION THAT THE PERSONS RECEIVING THE SAME WILL MAKE THEIR OWN DETERMINATION AS TO ITS SUITABILITY FOR THEIR USE. IN NO EVENT WILL 3M PURIFICATION BE RESPONSIBLE FOR DAMAGES OF ANY NATURE WHATSOEVER RESULTING FROM THE USE OF OR RELIANCE UPON INFORMATION.

It is your responsibility to determine if additional testing or information is required and if this product is fit for a particular purpose and suitable in your specific application.

3M PURIFICATION MAKES NO REPRESENTATIONS OR WARRANTIES, EITHER EXPRESS OR IMPLIED INCLUDING WITHOUT LIMITATION ANY WARRANTIES OF MERCHANTABILITY, FITNESS FOR A PARTICULAR PURPOSE OR OF ANY OTHER NATURE HEREUNDER WITH RESPECT TO INFORMATION OR THE PRODUCT TO WHICH INFORMATION REFERS.

#### Limitation of Liability

3M Purification will not be liable for any loss or damage arising from the use of the Product(s), whether direct, indirect, special, incidental, or consequential, regardless of the legal theory asserted, including warranty, contract, negligence or strict liability. Some states do not allow the exclusion or limitation of incidental or consequential damages, so the above limitation may not apply to you.

## LENNTECH

info@lennotech.com Tel. +31-152-610-900

www.lennotech.com Fax. +31-152-616-289



3M is a registered trademark of the 3M Company. LifeASSURE, Betapure and Zeta Plus are registered trademarks of the 3M Company used under license.

Data may be subject to change without further notice.  
© 3M 2012. All rights reserved.

v.5 - DOC10082  
LITCTLAPDA1.EU - 0812



PDA 020 F 50 B  
PDA 020 F 50 C  
PDA 020 F 50 F  
PDA 020 F 50 J  
PDA 020 F 01 B  
PDA 020 F 01 C  
PDA 020 F 01 F  
PDA 020 F 01 J  
PDA 020 F 02 B  
PDA 020 F 02 C  
PDA 020 F 02 F  
PDA 020 F 02 J  
PDA 020 F 03 B  
PDA 020 F 03 C  
PDA 020 F 03 F  
PDA 020 F 03 J  
PDA 020 F 04 B  
PDA 020 F 04 C  
PDA 020 F 04 F  
PDA 020 F 04 J

PDA 020 M 01 AN  
PDA 020 M 02 AN

PDA 020 C 01 A  
PDA 020 C 01 B  
PDA 020 C 02 A  
PDA 020 C 02 B  
PDA 020 J 01 A  
PDA 020 J 02 A  
PDA 020 J 03 A