



# 10" KPAK: 10738 M-183-LPP MODULE

## Zero Bypass E-Coat Ultrafiltration Spiral Modules

### PRODUCT DESCRIPTION

<b>KMS Part Number (KPN):</b>	0750985
<b>Membrane Chemistry:</b>	PVDF
<b>Membrane Type:</b>	HFM (Positive Charge)
<b>Membrane Area:</b>	462 ft <sup>2</sup> (42.9 m <sup>2</sup> )
<b>Construction:</b>	Spiral wound element with integrated PVC housing
<b>Feed Spacer Thickness:</b>	30 mils (0.76 mm)
<b>Interconnecting Components:</b>	See page 2.

### OPERATING & DESIGN INFORMATION\*

<b>Maximum Inlet Pressure at Temperature:</b>	80.0 psi @ 100° F (5.5 bar @ 37 °C)
<b>Maximum Inlet Pressure at Temperature:</b>	56.0 psi @ 120° F (3.9 bar @ 49 °C)
<b>Maximum Operating Temperature at Pressure:</b>	125° F @ 49 psi (51.6 °C @ 3.4 bar)
<b>Minimum Outlet Pressure:</b>	10.0 psi (0.70 bar)
<b>Maximum Permeate Side Back Pressure:</b>	5.0 psi (0.34 bar)
<b>Maximum Feed Side Pressure Drop:</b>	35.0 psi @ 125° F (2.4 bar @ 51.6° C)
<b>Allowable pH – Continuous Exposure:</b>	2.0 – 10.0 pH @ 125 °F (51.6 °C)
<b>Allowable pH – Short Term Exposure:</b>	1.5 – 10.5 pH @ 125 °F (51.6 °C)

\*Koch Membrane Systems, Inc. must review operating and cleaning conditions for all new plants and any changes to existing plants

### FEED FLOW VS. PRESSURE DROP (Typical)\*

	Circulation Flow		Pressure Drop	
	gpm	m <sup>3</sup> /hr	psi	bar
	97	21.6	25	1.7
	109	24.3	30	2.1
	117	26.1	35	2.4

\*Data are based on water @ 77°F and a specific gravity of 1.0. Circulation rates exhibit variances of ± 15%.

### NOMINAL DIMENSIONS

<b>Element Length:</b>	38.0 in (965 mm)
<b>Element O.D.:</b>	10.75 in (273.1 mm)
<b>Permeate Tube I.D.:</b>	1.3 in (33.0 mm)
<b>Element Shipping Weight:</b>	95 lbs (43 kg)
<b>Element Working Weight:</b>	150 lbs (68.2 kg)

# 10" KPAK SPIRAL MODULE ASSEMBLY

## Description

Item	Description	Material	KPN	Req
1	Outlet End Cap	304 SS	1006160	1
2	Inlet End Cap	304 SS	1006164	1
3	O-Ring (2-215)	EPDM	1006103	4
4	10" Coupling	Steel	1006149	2
5	10" Gasket	EPDM	1009255	2
6	Permeate Plug	PVC	1006162	1
7	ATD	304 SS	1006163	2
8	ATD Spacer	304 SS	1006168	6
9	2" Coupling *	Steel/EPDM	0151258	2

\*Not shown

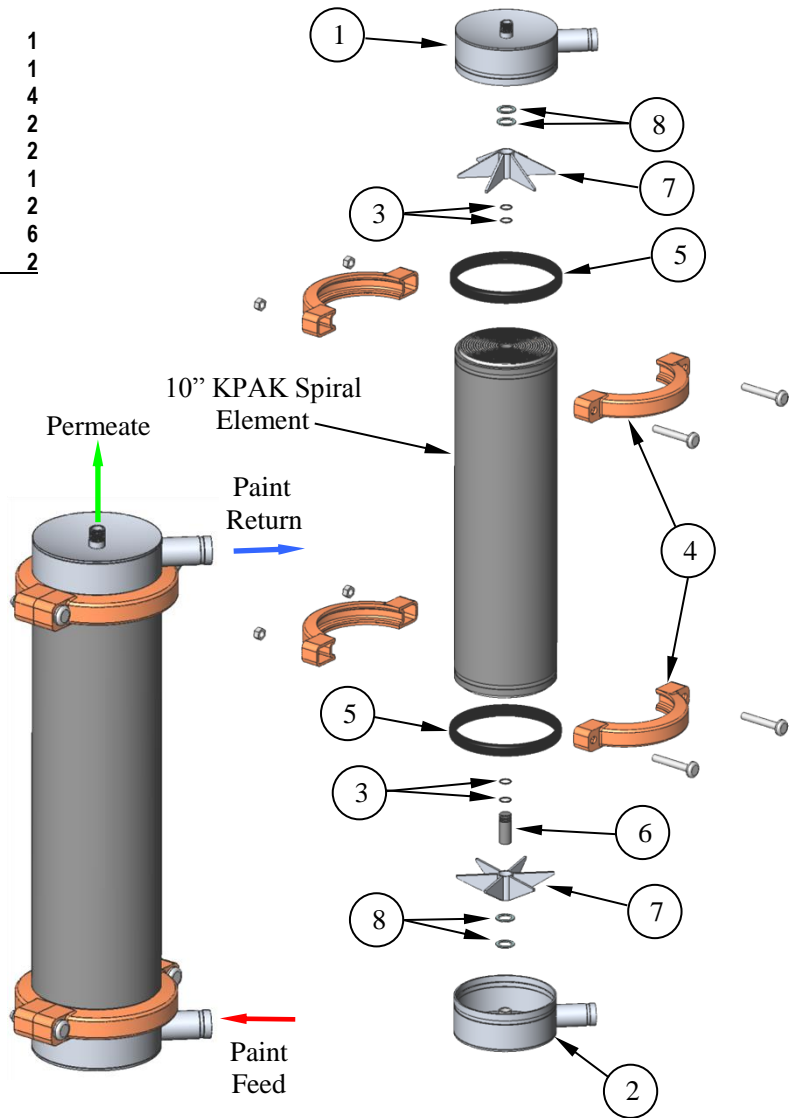
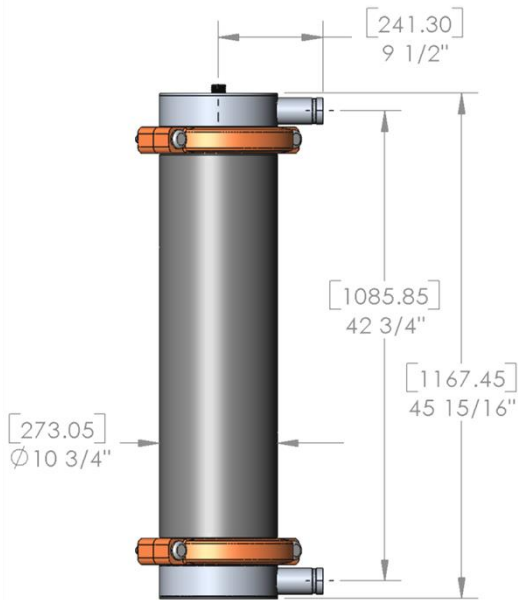

The information contained in this publication is believed to be accurate and reliable, but is not to be construed as implying any warranty or guarantee of performance. We assume no responsibility, obligation or liability for results obtained or damages incurred through the application of the information contained herein. Refer to Standard Terms and Conditions of Sale and Performance Warranty documentation for additional information.

**LENNTECH**

info@lenntech.com Tel. +31-152-610-900  
www.lenntech.com Fax. +31-152-616-289