

TARGA® II HOLLOW FIBER CARTRIDGES

8-inch Water Ultrafiltration Cartridges

PRODUCT DESCRIPTION

Membrane Chemistry:	Proprietary Semi-Permeable Polyethersulfone
Molecular Weight Cutoff:	100,000
Housing Shell/End Caps:	Proprietary Polysulfone
Fiber Support Netting:	Polypropylene/Polyethylene
Permeate Collection Tube:	PVC
Potting Material:	Proprietary Compound
Membrane Construction:	Hollow Fiber
Storage Solution:	Glycerin
Regulatory Status:	Classified by UL to NSF/ANSI Standard 61 and in accordance with NSF/ANSI Standard 372

PRODUCT SPECIFICATIONS

Part Number	Model	Fiber Diameter [Inch (mm)]	Membrane Area [ft ² (m ²)]	Production Range [gpm (m ³ /hr)]
0720425	TARGA II 8048-35	0.035 (0.9)	346 (32.1)	9.6 - 20.4 (2.2 - 4.6)
0720426	TARGA II 8072-35	0.035 (0.9)	544 (50.5)	15.1 - 32.1 (3.4 - 7.3)
0720427	TARGA II 8H072-35	0.035 (0.9)	544 (50.5)	15.1 - 32.1 (3.4 - 7.3)

OPERATING & DESIGN INFORMATION

Maximum Pressure (water):	45 psi (3.0 bar) @ 104° F (40°C) or less
Temperature Range:	32°F (0°C) - 104°F (40°C)
Maximum Production Transmembrane Pressure:	30 psi (2.1 bar)
Maximum Backflush Transmembrane Pressure:	25 psi (1.4 bar)
Allowable pH Range:	1.5 - 13
Maximum Total Chlorine @ 77° F (25° C) or lower:	500 ppm @ pH >10
Recommended Total Chlorine @ 77°F (25°C) or lower:	200 ppm @ pH >10
Maximum Backflush Total Chlorine @ 77°F (25°C) or lower:	50 ppm @ pH >9

NOMINAL DIMENSIONS*

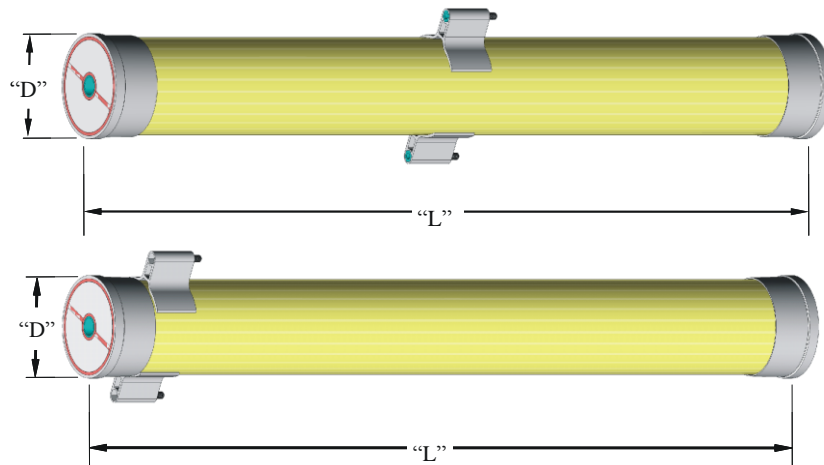

Model H

Model	Fiber Diameter (ID)	D Inches (mm)	L Inches (mm)
TARGA II 8048-35	0.035 inch (0.9 mm)	8.4 (213)	48 (1219)
TARGA II 8072-35	0.035 inch (0.9 mm)	8.4 (213)	72 (1829)
TARGA II 8H072-35	0.035 inch (0.9 mm)	8.4 (213)	72 (1829)

* Dimensions are provided for reference only and should not be interpreted as accurate specifications.

TARGA® II HOLLOW FIBER CARTRIDGE

CARTRIDGE STORAGE CONDITIONS:

New cartridges are packaged in a glycerin/water solution. The glycerin/water solution should be removed from new cartridges before their initial use with a water rinse followed by a caustic wash followed by caustic/chlorine wash. See the pre-startup cleaning instruction sheet packed with each cartridge shipment for more details. Prior to installation, cartridges should be stored in their original packaging under the following conditions:

- Indoors, out of direct sunlight.
- Temperatures between 50 – 85°F (10 – 30°C).
- Relative humidity below 70%.
- In a horizontal position.

It is best to use new cartridges within one year of shipment. Consult KMS for recommendations for longer term storage.

Used cartridges should be cleaned, rinsed and impregnated before storage with one of the following solutions:

- Glycerin @ 80 – 100% (best)
- Phosphoric acid @ pH 2 – 3
- Benzoic acid or sodium benzoate @ 1,000 ppm
- Sodium bisulfite or sodium metabisulfite @ 1,000 – 5,000 ppm

Cartridges stored in sodium bisulfite or sodium metabisulfite should be flushed with clean water and impregnated with fresh solution at six-month intervals. Once impregnated the cartridges should be left on the system with all valves closed or removed from the system and sealed in plastic bags. Storage conditions described above for new cartridges should also be used for storage of used cartridges. Cartridges must be drained, rinsed, and cleaned after storage per the pre-startup cleaning instruction sheet packed with each cartridge shipment.

CARTRIDGE ASSEMBLY AND COMPONENTS:

Item	Description	Required
1	8" HF Cartridge	1 each
2	Leveling Hardware (Screw ½" X 13)	2 each
3	Leveling Hardware (Nut ½" X 13)	2 each
4	8" Coupling Set (gasket included)	2 each
5	O-Ring, Permeate Adapter	8 each
6	Permeate Adapter	2 each
7	2.5" Coupling Set (gasket included)	2 sets
8	End Cap	2 each

Process Pass Kit for 8" cartridge – KMS Part Number 0220158.

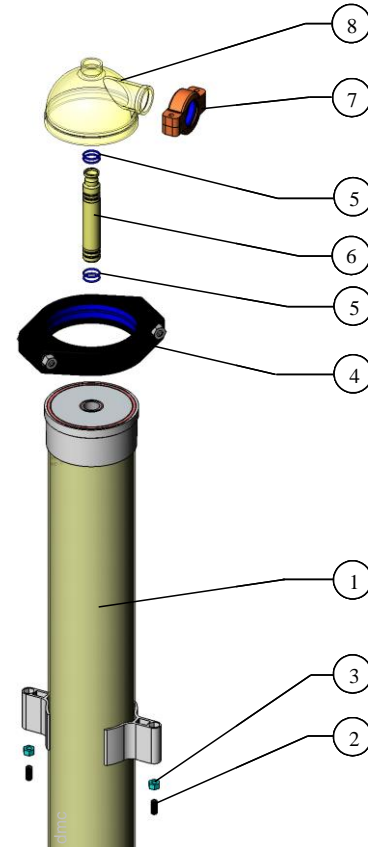

The information contained in this publication is believed to be accurate and reliable, but is not to be construed as implying any warranty or guarantee of performance. We assume no responsibility, obligation or liability for results obtained or damages incurred through the application of the information contained herein. Refer to Standard Terms and Conditions of Sale and Performance Warranty documentation for additional information.

LENNTECH

info@lennotech.com Tel. +31-152-610-900

www.lennotech.com Fax. +31-152-616-289