

DAB pump K

TWIN IMPELLERS CENTRIFUGAL PUMPS

LENNTECH

info@lenntech.com

www.lenntech.com

Tel. +31-15-261.09.00

Fax. +31-15-261.62.89



DOMESTIC, CIVIL AND INDUSTRIAL WATER SUPPLY

Twin impeller centrifugal pump designed for use in pressurisation units for water supply systems for domestic, civil and industrial use. Suitable for sprinkling irrigation and other water supply applications. Cast iron pump body and motor support. Technopolymer impeller. Stainless steel driving shaft. Carbon/ceramic mechanical seal. Asynchronous, closed motor, cooled by external ventilation.

Built-in thermal and current overload protection and a capacitor permanently on in the single-phase version. For the protection of the three-phase motor it is advisable to use a suitable overload protection complying with the regulations in force.

Operating range: from 1.2 to 30 m³/h with head up to 97 metres.

Pumped liquid characteristics: clean, free from solids or abrasive substances, not viscous, not aggressive, not crystallised, chemically neutral and close to the characteristics of water.

Liquid temperature range:

from -10°C to +50°C: for K 35/40, K 45/50, K 35/100, K 40/100, K 55/100

from -15°C to +110°C: for K 55/50, K 66/100, K 90/100, K 70/300, K 80/300, K 70/400, K 80/400.

Maximum operating range:

K 35/40, K 35/100, K 40/100: 6 bar (600 kPa)

K 45/50, K 55/50: 8 bar (800 kPa)

K 55/100, K 66/100: 10 bar (1000 kPa)

K 90/100, K 70/300, K 80/300 K 70/400, K 80/400: 12 bar (1200 kPa).

Maximum ambient temperature: +40°C.

Protection level: IP 44.

Terminal board protection level: IP 55.

Insulation class: F.



K 35/40 M



K 70/300 T

TECHNICAL DATA

MODEL	CODE	ELECTRICAL DATA						
		VOLTAGE 50 Hz	P1 MAX kW	P2 NOMINAL		In A	CAPACITOR	
				kW	HP		µF	Vc
K 35/40 M	102120004	1 x 230 V ~	1,2	0,75	1	5,5	20	450
K 35/40 T	60145196	3 x 230 - 400 V ~	1,2	0,75	1	3,8-2,2	-	-
K 35/40 M-P**	102122004	1 x 230 V ~	1,2	0,75	1	5,5	20	450
K 45/50 M	102120022	1 x 230 V ~	1,86	1,1	1,5	8,3	31,5	450
K 45/50 T	60145774	3 x 230 - 400 V ~	1,96	1,1	1,5	6-3,5	-	-
K 45/50 M-P**	102122022	1 x 230 V ~	1,86	1,1	1,5	8,3	31,5	450
K 45/50 T-P **	60147310	3 x 230 - 400 V ~	1,96	1,1	1,5	6-3,5	-	-
K 55/50 M	102120162	1 x 230 V ~	2,7	1,85	2,5	12,8	40	450
K 55/50 T	60145840	3 x 230 - 400 V ~	2,5	1,85	2,5	8,4-4,8	-	-
K 55/50 M-P**	102122030	1 x 230 V ~	2,7	1,85	2,5	12,8	40	450
K 55/50 T-P **	60147311	3 x 230 - 400 V ~	2,5	1,85	2,5	8,4-4,8	-	-

* NEW IE2 MOTOR

** Pump equipped with pressure gauge, pressure switch, power cable with plug and five-way fitting to use for connecting to a tank.

MODEL	CODE	ELECTRICAL DATA						
		VOLTAGE 50 Hz	P1 MAX kW	P2 NOMINAL		In A	CAPACITOR	
				kW	HP		μF	Vc
K 35/100 M	102121002	1 x 230 V ~	1,56	1,1	1,5	7,1	25	450
K 35/100 T	60145775	3 x 230 - 400 V ~	1,56	1,1	1,5	5,36-3,1	-	-
K 40/100 M	102121032	1 x 230 V ~	2	1,85	2,5	9	40	450
K 40/100 T	60145841	3 x 230 - 400 V ~	2	1,85	2,5	6,2-3,6	-	-
K 55/100 T	60146054	3 x 230 - 400 V ~	3,9	2,2	3	11,6-6,7	-	-
K 66/100 T	60146067	3 x 230 - 400 V ~	4,7	3	4	14,6-8,4	-	-
K 90/100 T	60146068	3 x 230 - 400 V ~	5,4	4	5,5	16,5-9,5	-	-
K 70/300 T*	60146091	3 x 400 V ~ ¹	7,1	5,5	7,5	12,9	-	-
K 80/300 T*	60146097	3 x 400 V ~ ¹	9,9	7,5	10	15	-	-
K 70/400 T*	60146108	3 x 400 V ~ ¹	10,7	9,2	12,5	18	-	-
K 80/400 T*	60146114	3 x 400 V ~ ¹	12,5	11	15	21	-	-

* NEW IE2 MOTOR

** Pump equipped with pressure gauge, pressure switch, power cable with plug and five-way fitting to use for connecting to a tank.

¹ Star delta starting

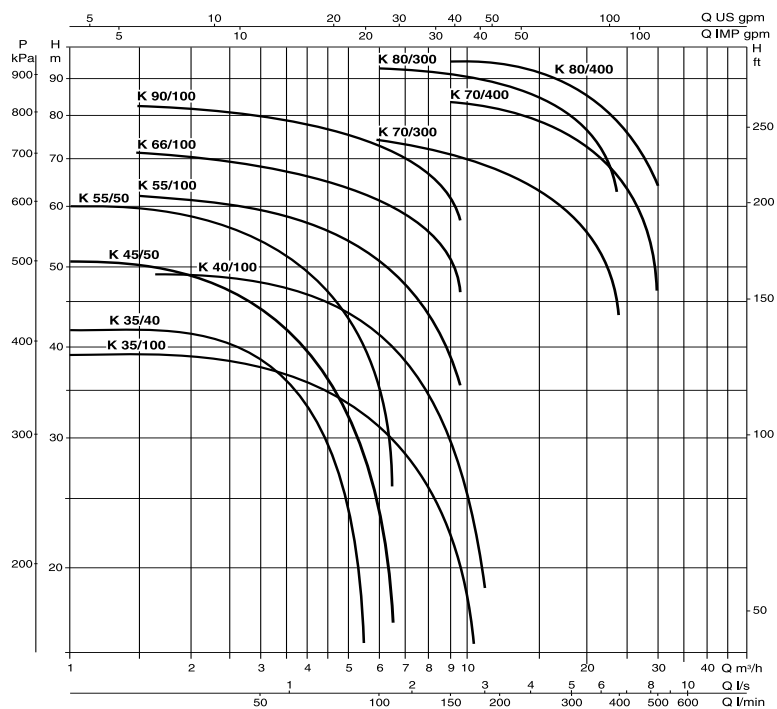

DIMENSIONS AND WEIGHTS

K 35/40

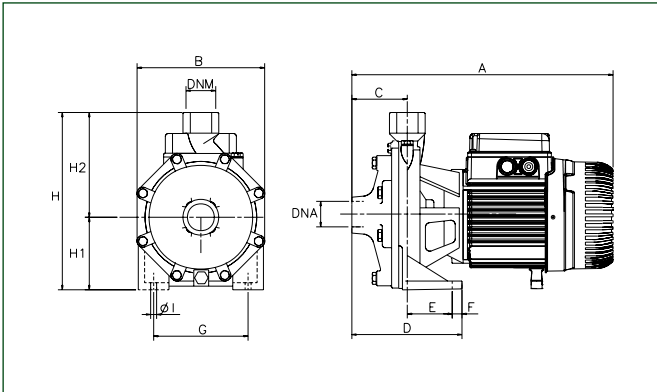

K 45/50 - 55/50 - 66/100 - 90/100

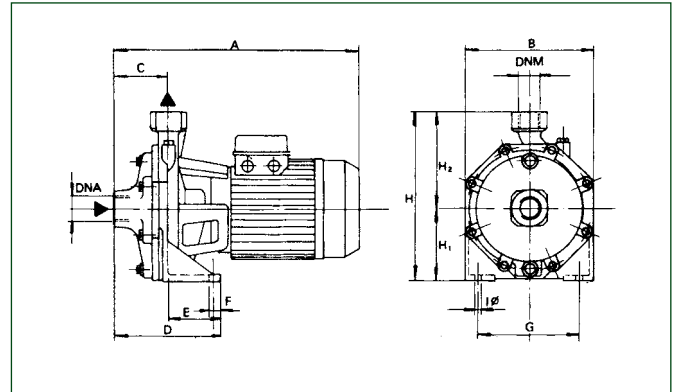

K 35/100 - 40/100

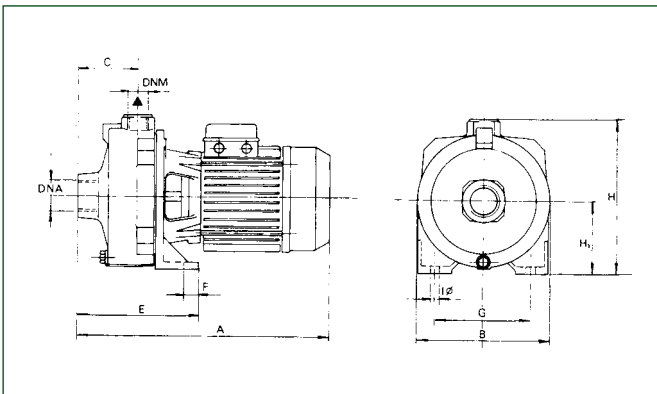

K 70/300 - 80/300 - 70/400 - 80/400

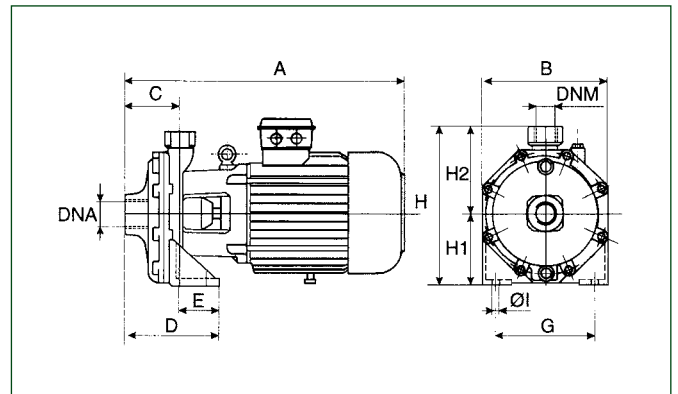

MODEL	A	B	C	D	E	F	G	ØI	H	H1	H2	DNA	DNM	WEIGHT KG	Q.TY X PALLET
K 35/40	342	180	76	148	72	15	148	9,5	235	100	135	1" G	1" G	15,9	27
K 45/50	370	210	75	144	69	15	165	11,5	268	118	150	1 1/4" G	1" G	23,3	21
K 55/50	370	210	75	114	69	15	165	11,5	268	118	150	1 1/4" G	1" G	27,2	18
K 35/100	387	205	88	-	179	20	145	11	233	108	-	1 1/2" G	1" G	22	21
K 40/100 M	461	205	88	-	179	20	145	11	233	108	-	1 1/2" G	1" G	25,9	18
K 40/100 T	387	205	88	-	179	20	145	11	233	108	-	1 1/2" G	1" G	22	21
K 55/100	450	256	88	160	72	18	200	14	312,5	140	172,5	1 1/2" G	1" G	38,1	18
K 66/100	450	256	88	160	72	18	200	14	312,5	140	172,5	1 1/2" G	1" G	40,7	18
K 90/100	450	256	88	160	72	18	200	14	312,5	140	172,5	1 1/2" G	1" G	44	18
K 70/300	595	270	122	182	60	20	210	14	340	160	180	2" G	1 1/4" G	72	6
K 80/300	595	270	122	182	60	20	210	14	340	160	180	2" G	1 1/4" G	79	6
K 70/400	635	270	122	182	60	20	210	14	340	160	180	2" G	1 1/4" G	75	6
K 80/400	635	270	122	182	60	20	210	14	340	160	180	2" G	1 1/4" G	79	6