

DAB pump FEKABOX 280

AUTOMATIC PUMPING STATION

LENNTECH

info@lennotech.com

www.lennotech.com

Tel. +31-15-261.09.00

Fax. +31-15-261.62.89



WASTE WATER COLLECTION AND LIFTING

Automatic collection and lifting stations, used for collecting and pumping civil and industrial waste water in sewers. Comprises a high density 280 litre polythene tank with removable cover complete with a watertight and gastight seal.

Fekabox series is suitable only for the use of one single phase automatic pump from the following: **FEKA 600 M-A - FEKA VS 550 M/A - FEKA VS 750 M/A - FEKA VX 550 M/A - FEKA VX 750 M/A, GRINDER GL 1000 MA to be ordered separately.**

Complete with: special cable holder, DN50 and DN110 suction manifolds and 2" delivery manifolds.

Complete with connector for DN50 vent tube. An alarm float can be used on request. Complete with lifting device (DSD2) for making pump maintenance easier.

Operating range: from 1 to 32 m³/h with a head of up to 23 m.

Liquid temperature range: +50°C.

Pumped liquid: ground water, rain water, clear waste water, black waste water and water from rivers and lakes.



TECHNICAL DATA

MODEL	CODE	CAPACITY [lt]	DIMENSION [mm]	TO BE USED WITH	DN PIPES [mm]
FEKABOX 280	60114028	280	750x585x900	FEKA 600 MA, FEKA VS/VX 550-750- 1000-1200 MA GRINDER GL 1000 MA	2xDN150, 3xDN110, 2xDN50 inlet 1xDN50 ventilation 1xDN40 emergency emptying

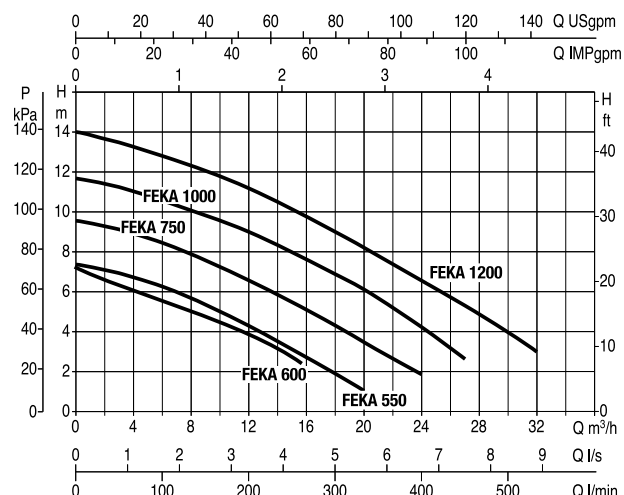

DIMENSIONS AND WEIGHTS

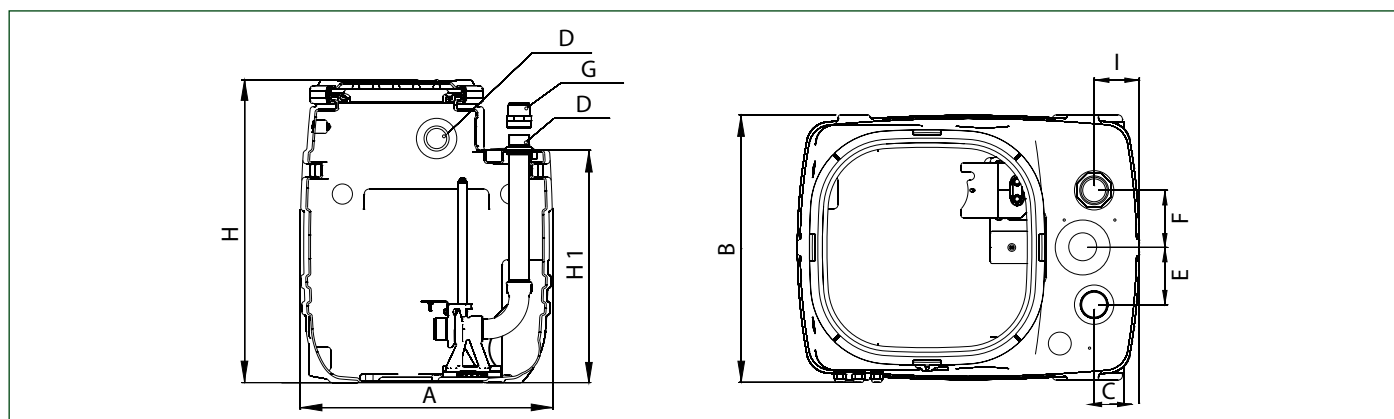

MODEL	A	B	C	D	E	F	G	H	H1	I	WEIGHT KG.
FEKABOX 280	750	585	99	DN 50/110	125	125	2" - Ø 63	900	690	124,5	34

SUBMERSIBLE PUMPS