

# DAB pump FEKABOX 200

AUTOMATIC PUMPING STATION



## WASTE WATER COLLECTION AND LIFTING

Automatic collection and lifting stations, used for collecting and pumping civil and industrial waste water in sewers.

Comprises a high density 200 litre polythene tank with removable cover complete with a watertight and gastight seal.

Fekabox series is suitable only for the use of one single phase automatic pump from the following: **FEKA 600 MA, FEKA VS/VX 550-750-1000-1200 MA, GRINDER GL 1000 MA, to be ordered separately.**

**Complete with:** 2" PVC unions special cable holder and cable gland, DN50 and DN110 suction manifolds and 2" delivery manifolds. Complete with connector for DN50 vent tube. An alarm float can be used on request.

**Operating range:** from 1 to 32 m<sup>3</sup>/h with a head of up to 15 m

**Liquid temperature range:** +50°C

**Pumped liquid:** ground water, rain water, clear waste water, black waste water and water from rivers and lakes.



## TECHNICAL DATA

MODEL	CODE	CAPACITY [t]	DIMENSION [mm]	TO BE USED WITH	DN PIPES [mm]
FEKABOX 200	60116632	200	750x579x700	FEKA 600 MA, FEKA VS/VX 550-750-1000-1200 MA GRINDER GL 1000 MA	3xDN110, 1xDN50, 1xDN75 inlet, 1xDN75 ventilation, 1xDN40 emergency emptying

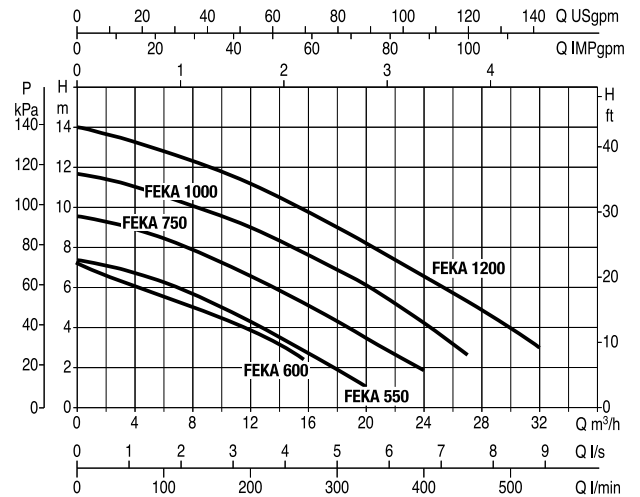

## DIMENSIONS AND WEIGHTS

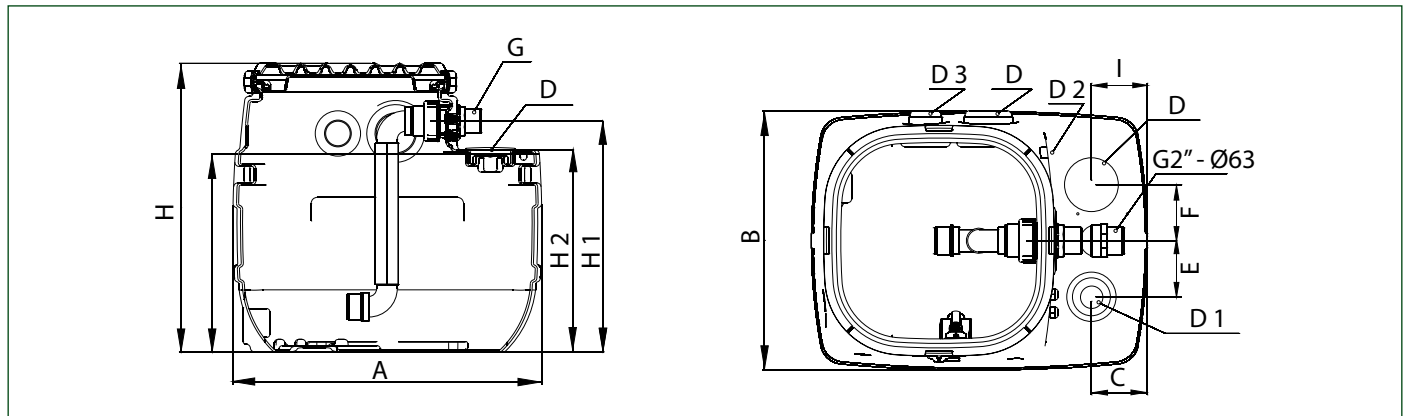

MODEL	A	B	C	D	D1	D2	D3	E	F	G	H	H1	H2	I	WEIGHT KG.
FEKABOX 200	750	579	124,5	DN 110	DN 50/110	DN 75	DN 110	125	125	2"	700	560	490	124,5	25