

DAB pump FEKABOX 110

AUTOMATIC PUMPING STATION



WASTE WATER COLLECTION AND LIFTING

Automatic collection and lifting stations, used for collecting and pumping civil waste water in sewers. FEKABOX 110 is made of a 110 litres polyethylene tank with cover including plastic seal. Fekabox series is suitable only for the use of one single phase automatic pump from the following: **FEKA 600 M/A - FEKA VS 550 M/A - FEKA VS 750 M/A - FEKA VX 550 M/A - FEKA VX 750 M/A**, to be ordered separately.

Complete with: 2" PVC unions and cable gland.
Operating range: from 1 to 24 m³/h with head up to 9 m.
Liquid temperature range: + 50°C.
Pumped liquid: sewage and household waste.



TECHNICAL DATA

MODEL	CODE	CAPACITY [lit]	DIMENSION [mm]	TO BE USED WITH	DN PIPES [mm]
FEKABOX 110	60123162	110	700x380x560	FEKA 600 MA, FEKA VS/VX 550-750 MA	3xDN110, 2xDN50 inlet 1xDN50 ventilation 1xDN40 emergency emptying

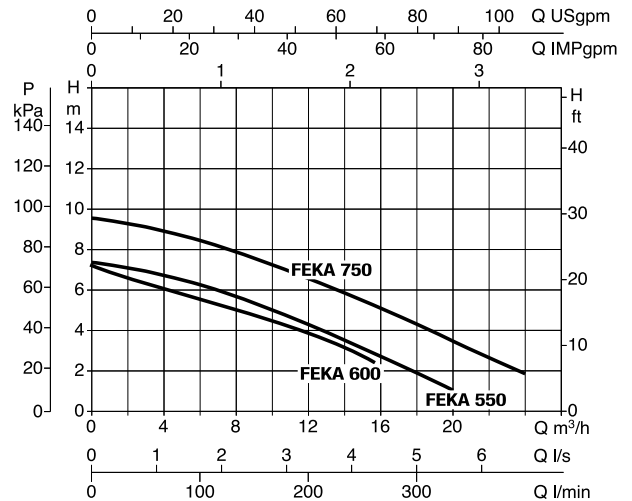

DIMENSIONS AND WEIGHTS

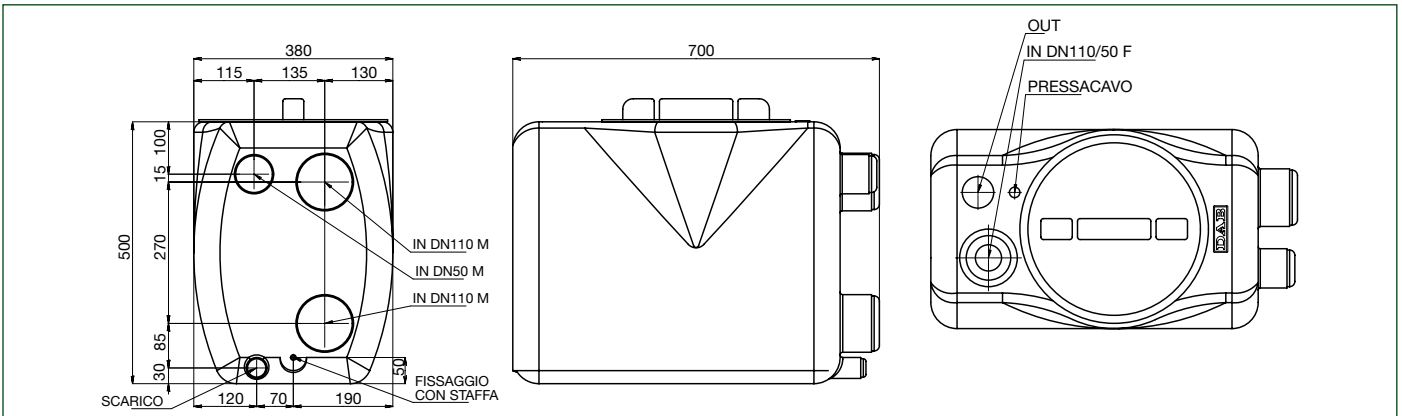

MODEL	A	B	C	D	E	F	G	H	H1	H2	H3	H4	H5	I	WEIGHT KG.
FEKABOX 110	700	190	70	120	380	115	135	270	100	15	85	30	50	130	8,5