

DAB Pump DRENAG 1600 - 2000 - 2500 - 3000

DRAINAGE PUMPS



CLEAN AND GREY WATER ON BUILDING SITES

Submersible centrifugal pump with **ADJUSTMENT RING IMPELLER** suitable for lifting water from drainage waste containing solids having maximum size of **5 mm**. Top cover and motor body in anodized die cast aluminium. Impeller in ENGJL 200 cast iron. Pump body in ENGJL 200 cast iron. Double mechanical seals in oil chamber: motor side carbon/alumina, pump side in silicon carbide/silicon carbide. Dry type asynchronous sealed motor. Rotor mounted on ball bearings to ensure silent running and long life. In the single phase version capacitor is supplied in external control box equipped with current protection

Protection level: IP 68.

Insulation class: F.

Continuous duty, with completely immersed pump. The single-phase version can be equipped with float switch for automatic starting and stopping of the pump. Supplied as standard with 10 metre H07RN-F power cable.

Operating range: from 3 to 66 m³/h with head up to 17 mt.

Liquid quality requirements: Clear drain not aggressive water.

Liquid temperature range: from 0° to + 40°.

Maximum immersion depth: 10 mt.

Installation: portable, in vertical position.

Free passage through the suction grid: 5 mm.



TECHNICAL DATA

MODEL	CODE	ELECTRICAL DATA						
		VOLTAGE 50 HZ	P1 MAX kW	P2 NOMINAL		In A	CAPACITOR	
				kW	HP		µF	VC
Drenag 1600 M-A	60141710	1X230 V~	1,6	1,1	1,5	7,4	30	450
Drenag 1600 T-NA	60141711	3X400 V~	1,6	1,1	1,5	3	-	-
Drenag 2000 T-NA	60141712	3X400 V~	2	1,4	1,9	4,1	-	-
Drenag 2500 T-NA	60141713	3X400 V~	3,1	1,8	2,4	5,3	-	-
Drenag 3000 T-NA	60141714	3X400 V~	3,5	2,2	2,9	6,2	-	-

A= automatic with float NA= non automatic without float

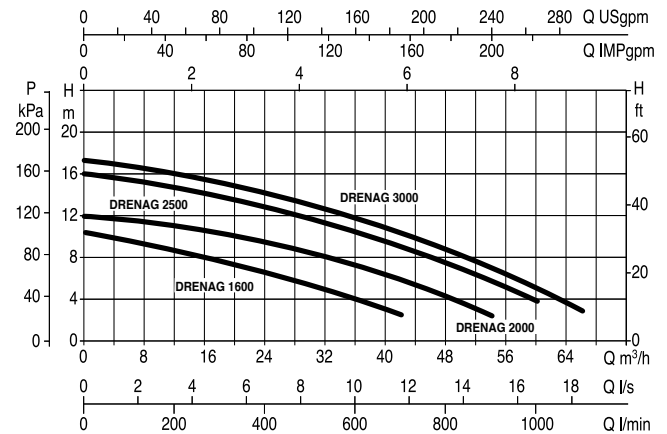

DIMENSIONS AND WEIGHTS

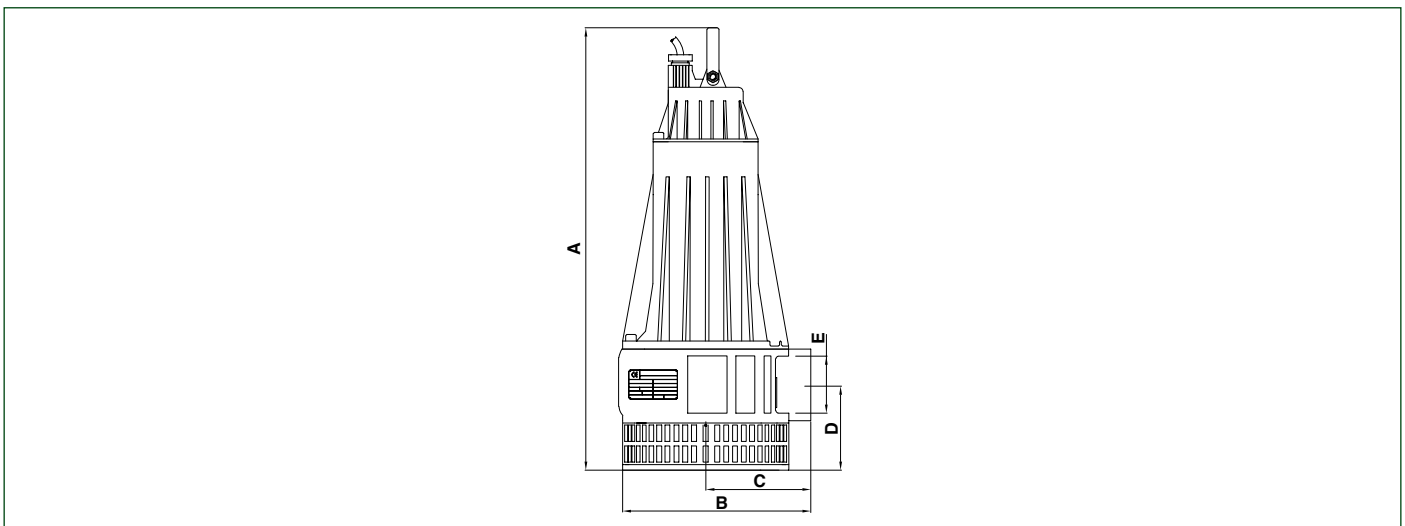

MODEL	A	B	C	D	E - DNM GAS	FREE PASSAGE mm	Q.TY X PALLET	WEIGHT KG
Drenag 1600 M-A	550	215	112	110	2" 1/2	5	8	23,5
Drenag 1600 T-NA								23,5
Drenag 2000 T-NA								23,5
Drenag 2500 T-NA								24
Drenag 3000 T-NA								26