

**VIEW AT CENTER SUPPORT**  
 CENTER VESSEL ON 2 OR 3 SUPPORTS  
 AT SPAN(S) "S"; 3 SUPPORTS REQUIRED  
 FOR LENGTHS 4 AND ABOVE

DWG REF	QTY	PART NUMBER	DESCRIPTION	MATERIAL
<b>SHELL</b>				
1	1	ORDER SECTION	SHELL	Filament Wound Epoxy/Glass composite - Head locking grooves integrally wound in place.
2	A/R		F/C Port	CF3M *
3	A/R		F/C Port Seal	Ethylene Propylene
<b>HEAD</b>				
4	2	96157	Bearing Plate	6061-T6 Aluminium alloy - Hard anodized
5	2	96159	Sealing Plate	Engineering Thermoplastic.
6	2	96262	Spacer	Engineering Thermoplastic.
7	2	96263	Permeate Port	Engineering Thermoplastic.
8	2	45066	Port Nut	Engineering Thermoplastic.
9	2	96000	Head Seal	Ethylene Propylene - O - Ring
10	2	45312	Perm Port Seal	Ethylene Propylene - O - Ring
<b>HEAD INTERLOCK</b>				
11	2	47336	Quick Release Spiral Ring	316 Stainless Steel.
<b>VESSEL SUPPORT</b>				
12	* 2	52169	Saddle	Engineering Thermoplastic.
13	* 2	45042	Strap Assy.	304 Stainless Steel-PVC Cushion.
14	4	46265	Strap screw.	5/16-18 UNC, 18-8 Stainless Steel.
<b>ELEMENT INTERFACE</b>				
15	2	A/R	Adapter	Engineering Thermoplastic.
16	2	52245	Adapter seal	Ethylene Propylene - O - Ring
17	4	A/R	PWT Seal	Ethylene Propylene - O - Ring
18	1	96163	Thrust Cone	Engineering Thermoplastic.

\* 3 each furnished with length code 4,5,6,7&8.

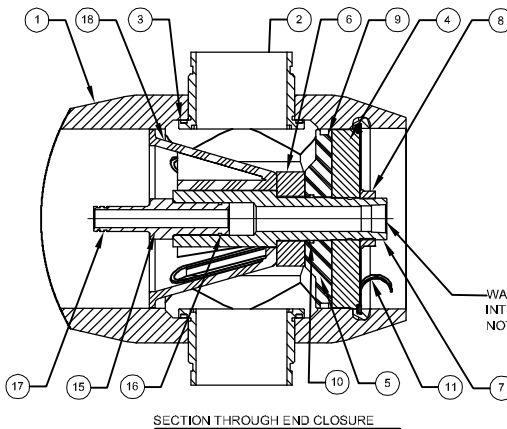

**NOTES:-**  
 •MAX. ANGULAR VARIATION BETWEEN ANY PORTS ±0.5°.  
 •DIMENSION IN INCHES (MM APPROX.)  
 •SHELL EXTERIOR COATED WITH WHITE, HIGH GLOSS POLYURETHANE PAINT.  
 •ITEM 18 DOWNSTREAM ONLY.  
 •NOT TO BE USED FOR CONSTRUCTION UNLESS CERTIFIED.  
 \* GRADE CF3M PER ASME SA-351/316L AS PER SA-479.  
 # 600 PSI FOR METALLIC PERMPORTS

**CAUTION: INCORRECT MANIFOLDING WILL CAUSE SEVERE LOCAL STRESS AROUND PORT AND MAY RESULT IN LEAKS AND PREMATURE FAILURE; TAKE EVERY PRECAUTION LISTED ON REVERSE, SEE INSTALLATION INSTRUCTIONS FOR FURTHER DETAILS**

PO NUMBER	-1	63.25 (1607)	48 (1219)	9X1 (228)	110 (50)			
CUSTOMER NAME	-2	103.25 (2623)	88 (2235)	49X1 (1244)	129 (59)			
PROJECT NAME	-3	143.25 (3639)	128 (3251)	80X1 (2032)	148 (67)			
TOTAL QUANTITY	-4	183.25 (4655)	168 (4267)	64X2 (1626)	167 (76)			
<b>PORT CONFIGURATION DETAILS</b>								
PORT CONFIG	VESSEL QUANTITY	-5	223.25 (5671)	208 (5283)	78X2 (1981)			
		-6	263.25 (6687)	248 (6299)	92X2 (2337)			
		-7	303.25 (7703)	288 (7315)	106X2 (2692)			
		-8	343.25 (8719)	328 (8331)	120X2 (3048)			
DRAWN	FF	 <b>CodeLine - 80U45</b> <b>MEMBRANE HOUSING</b>						
CHECKED	RD					DATE	DWG. NO.	REV. D
APPROVED	RM					25 JUL 11	99189	D
		ECN	SCALE	SIZE	SHEET			
		2243	NONE	A3	1 OF 3			

**RATING:**

DESIGN PRESSURE.....450 PSIG at 190°F  
(3.1 MPa at 88°C)  
MIN. OPERATING TEMP.....20°F  
(-7°C)  
FACTORY TEST PRESSURE..... CE / ASME  
675 PSIG / 495 PSIG  
(4.65 MPa) (3.41 MPa)  
QUALIFICATION PRESSURE .....2700 PSI  
(18.62 MPa)

**INTENDED USE:**

The CodeLine 80U45 Fiberglass RO Pressure Vessel is designed for continuous, long term use as housing for reverse osmosis membrane elements to desalt typical brackish waters at pressures up to 450 psi. Any make of eight-inch nominal diameter spiral-wound element is easily accommodated; the appropriate interfacing hardware for the element specified is furnished with the vessel.

The CodeLine 80U45 is designed in accordance with the engineering standards of the Boiler and Pressure Vessel Code of the American Society of Mechanical Engineers (ASME) Code. At small additional cost vessels can be inspected during construction by an ASME Authorized Inspector and ASME Code stamped.

The CodeLine 80U45 must be installed, operated and maintained in accordance with the listed precautions and good industrial practice to assure safe operation over a long service life.

The high performance Filament wound FRP shell must be allowed to expand under pressure; undue restraint at support points or piping connections can cause leaks to develop in the shell. This side-ported vessel requires special precautions in mounting and connection to piping so that the vessel will not be subjected to excessive stress due to bending moments acting at the side openings in the fiberglass shell. The end closure, incorporating close fitting, interlocking metal components, must be kept dry and free of corrosion; deterioration can lead to catastrophic mechanical failure of the head.

Pentair Water will assist the purchaser in determining the suitability of this standard vessel for their specific operating conditions. The final determination however, including evaluation of the standard material of construction for compatibility with the specific corrosive environment, shall be the responsibility of the purchaser. Alternate materials with enhanced corrosion resistance are available on special order.

Specifications are subject to change without notice.

**PRECAUTIONS:**

- DO...read, understand and follow all instructions; failure to take every precaution will void warranty and may result in vessel failure
- DO...mount the shell on horizontal members at span "S" using compliant vessel supports furnished; Shim saddles if required. Tighten hold down straps just snug
- DO...align and center side ports with the manifold header. Correct, causes of misalignment in a row of vessels connected to the same header
- DO...use flexible type grooved-end pipe couplings, Victaulic® Style 77 or equal, at side ports; allow full, 0.125 inch gap between port and piping, and position piping to maximize flexibility of connection.
- DO...provide flexibility in, and support for piping manifolds so that vessel can grow in length under pressure without undue restraint; provide additional flexible joints in large pipes leading to manifold header.
- DO...provide overpressure protection for vessel set at not more than 105% of design pressure
- DO...inspect end closures regularly; replace components that have deteriorated and correct causes of corrosion
- DO... Lubricate seals sparingly, using nonpetroleum Based lubricants, i.e. Parker Super O-lube®, Glycerin or suitable silicone based lubricants.
- DO NOT...work on any component until first verifying that pressure is relieved from vessel
- DO NOT...make rigid piping connections to ports or clamp vessel in any way that resists growth of fiberglass shell under pressure;  
\*\*\*ADIA = 0.015 in. (0.4mm) and  
\*\*\*ΔL = 0.2 in. (6mm) for a length code -8 vessel
- DO NOT... hang piping manifolds from ports or use vessel in any way to support other components
- DO NOT...tighten Permeate Port connection more than one turn past hand tight
- DO NOT... operate vessel without connecting both Permeate Ports internally to complete set of elements or otherwise plug ports internally so that external piping connection is not subjected to feed pressure
- DO NOT...install Spacer on downstream end of vessel
- DO NOT...operate vessel without Thrust Cone installed downstream
- DO NOT...pressurize vessel until double-checking to verify that the Locking Ring is in place and fully seated.
- DO NOT...operate vessel at pressure and temperature in excess of its rating.
- DO NOT...operate vessel with permeate pressure in excess of 125 psi at 190°F (0.86 Mpa at 88.°C).
- DO NOT...tolerate leaks or allow end closures to be routinely wetted in any way
- DO NOT...operate outside the pH range 3-10.

**ORDERING:**

Using the chart below, please check the features you require

**VESSEL LENGTH CODE – please check one**

MODEL 80U45  -1  -2  -3  -4  -5  -6  -7  -8

**MEMBRANE BRAND AND MODEL**

Please supply adapters for the following membrane brand and specific model  
Brand \_\_\_\_\_ Model \_\_\_\_\_

**CERTIFICATION REQUIRED**

- ASME Stamped and National Board Registered.
- CE Marked Standard.
- Certified by Pentair water.
- In compliance with the ASME Sec X but not Code Stamped.
  - Hydro testing at 1.1 times the design pressure
  - Hydro testing at 1.5 times the design pressure

ADAPTER KITS	
UP STREAM	DOWN STREAM

**PERMEATE PORT SELECTION**

Serial Number End

Size of the Permeate Port  1"  1.25"  1.5"  
Type of Connection  FNPT  MNPT  BSPTM  BSPTF  IPS GROOVED  
Material of Construction  PET/Noryl  SS316L  Zeron 100

Non Serial Number End

Size of the Permeate Port  1"  1.25"  1.5"  
Type of Connection  FNPT  MNPT  BSPTM  BSPTF  IPS GROOVED  
Material of Construction  PET/Noryl  SS316L  Zeron 100

**Note:**

- Standard offering is 1.0" FNPT in PET/Noryl.
- 1.25" & 1.5" BSPTF, 1.25" & 1.5" FNPT connections cannot be offered

**STRAP ASSEMBLY**

Standard SS304  Optional SS316  Optional SS316L

**FEED/CONCENTRATE PORT SELECTION**

Material of Construction  CF3M  Optional Duplex SS (CD3MN)  
 Optional Super Duplex SS (CD3MWCuN)

Configuration  Standard - CF3M 1151

Optional –Multi port: (Refer SPEC.SHEET/PM/4" for Multi ports selection).  
Ports not available in 90° configurations.

Serial number end

Opposite end

**BEARING PLATE MATERIAL**

Standard – 6061 T6 Aluminium  
 Optional – Stainless Steel 316L

**Note:** Refer page-3 for optional Part numbers.

PORT SIZE CODE	
D	1½" GROOVED END
E	2" GROOVED END
F	2½" GROOVED END
G	3" GROOVED END
I	4" GROOVED END

4

3

2

1

BEARING PLATE PART NUMBERS		
PERMEATE PORT SIZE	ALUMINIUM	SS316L
1.0"/1.25"	96157	96476
1.5"	96411	97373

SEALING PLATE PART NUMBERS	
Standard used for Aluminium BP	96159
Optional used for SS316L BP	97404

PERM PORT RETAINER RING & PORT NUT PART NUMBERS		
1.0" / 1.25"	Standard Port nut	45066
1.5"	Port Retainer Ring	45247

STRAP ASSEMBLY PART NUMBERS		
SS304	SS316	SS316L
45042	46926	94371

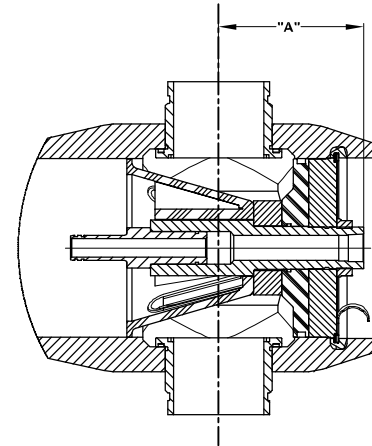

SECTION THROUGH END CLOSURE

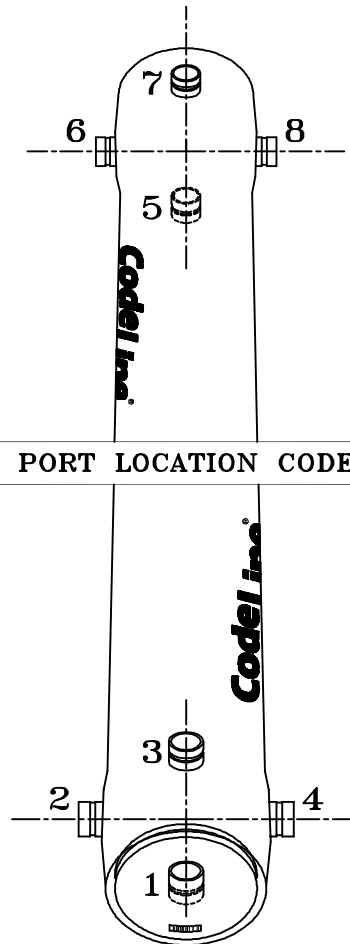

PORT LOCATION CODE

Serial Number End

F/C PORT & SEAL PART NUMBER				
SIZE	*CF3M	**CD3MN	***CD3MWCuN	SEAL
4"	96266	97444	96648	96265
3"	96567	97443	96663	96119
2.5"	96651	97442	96662	96079
2.0"	96650	97441	96661	96078
1.5"	96649	97440	96660	96077

PERMEATE PORT PART NUMBERS & PERMPORT TO F/C PORT OFFSET DISTANCE											
SIZE	MATERIAL	FNPT		MNPT		BSPTF		BSPTM		IPS GROOVED	
		PART NUMBER	DIM "A"	PART NUMBER	DIM "A"	PART NUMBER	DIM "A"	PART NUMBER	DIM "A"	PART NUMBER	DIM "A"
1.0"	PET/NORYL	96263	6.753	97411	7.753	97414	6.753	97417	7.753	97420	8.053
	SS316L	97410	6.753	97412	7.753	97415	6.753	97418	7.753	97421	8.053
	#ZERON 100	97296	6.753	97413	7.753	97416	6.753	97419	7.753	97422	8.053
1.25"	PET/NORYL	NA	NA	97467	7.753	NA	NA	97425	7.753	97428	8.053
	SS316L	NA	NA	97423	7.753	NA	NA	97426	7.753	97429	8.053
	#ZERON 100	NA	NA	97424	7.753	NA	NA	97427	7.753	97430	8.053
1.5"	PET/NORYL	NA	NA	97431	7.353	NA	NA	97434	7.353	97437	7.983
	SS316L	NA	NA	97432	7.353	NA	NA	97435	7.353	97438	7.983
	#ZERON 100	NA	NA	97433	7.353	NA	NA	97436	7.353	97439	7.983

## NOTES

DIMENSION IN INCHES (MM APPROX.)

\* GRADE CF3M PER ASME SA-351/316L AS PER SA-479

\*\* GRADE CD3MN AS PER ASME SPEC UNS -S32760 SA-995 (UNS-J92205)

\*\*\* GRADE CD3MWCuN AS PER ASME SPEC SA-995 (J 93380)

# GRADE ZERON 100 AS PER ASTM-479

O

k

u

7

www.lenntech.com

info@lenntech.com

DRAWN	KPS	MEMBRANE HOUSING			
	16 OCT 10	DATE	DWG. NO.	REV.	D
CHECKED	RD	25 JUL 11	99189		
	16 OCT 10	ECN	SCALE	SIZE	SHEET
APPROVED	RM	2243	NONE	A3	3 OF 3
	16 OCT 10				

Pentair Water  
CodeLine - 80U45

4

3

2

1

B

B

A

A