



LENNTECH

info@lenntech.com
 www.lenntech.com
 Tel. +31-15-261.09.00
 Fax. +31-15-261.62.89



25 Frame Plunger Pump

Standard Brass Model

Stainless Steel Model

2510
2511

FEATURES

- Triplex design delivers high efficiency and low pulsation.
- Durable dual V- packings are lubricated and cooled by pumped liquid.
- re-set Lo- pressure seals provide secondary protection against external leaks and require no packing adjustments.
- Special high-density, polished, concentric plungers provide a true wear surface and extended seal life.
- Specially formulated Seals and V- packings offer unmatched performance and extended life.
- Interchangeable inlet and discharge valves for easy servicing.
- Wet-end easily serviced without entering crankcase.

SPECIFICATIONS

MO EL 2510

Flow	20 gpm	(76 lpm)
Pressure Range	100 to 2000 psi	(7 to 140 bar)

MO EL 2511

Flow	20 gpm	(76 lpm)
Pressure Range	100 to 1500 psi	(7 to 105 bar)

COMMON SPECIFICATIONS

R M	1450 rpm	(1450 rpm)
Inlet Pressure Range	Flooded to 70 psi	(Flooded to 4.9 bar)
Bore	0.984"	(25 mm)
Stroke	1.516"	(38.5 mm)
Maximum Liquid Temperature	140°F	(60°C)
Above 130°F call CAT UM S for inlet conditions and elastomer recommendations.		
Inlet ports (2)	1-1/4" N TF	(1-1/4" N TF)
Discharge ports (2)	3/4" N TF	(3/4" N TF)
Valley Mounting	Either Side	(Either Side)
Shaft Diameter	1.181"	(30 mm)
Weight (2510)	79 lbs.	(36 kg)
(2511)	75 lbs.	(34 kg)

ELECTRIC HORSEPOWER REQUIREMENTS

MO EL	FLOW		PRESSURE					RPM
			psi 1000	psi 1200	psi 1500	psi 1800	psi 2000	
	U.S. gpm	lpm	bar 70	bar 85	bar 105	bar 125	bar 140	
2510	20	76	13.7	16.5	20.6	24.7	27.5	1450
	18	68	12.3	14.8	18.5	22.2	24.7	1305
	15	57	10.3	12.4	15.4	18.5	20.6	1088
2511	20	76	13.7	16.5	20.6	N/A	N/A	1450
	18	68	12.3	14.8	18.5	N/A	N/A	1305
	15	57	10.3	12.4	15.4	N/A	N/A	1088

⚠ CAUTIONS AND WARNINGS

All High Pressure Systems require a primary pressure regulating device (i.e. regulator, unloader) and a secondary pressure relief device (i.e. pop-off valve, relief valve). Failure to install such relief devices could result in personal injury or damage to pump or property. CAT PUMPS does not assume any liability or responsibility for the operation of a customer's high pressure system.

Read all CAUTIONS and WARNINGS before commencing service or operation of any high pressure system. The CAUTIONS and WARNINGS are included in each service manual and with each Accessory Data sheet. CAUTIONS and WARNINGS can also be viewed online at www.catpumps.com/cautions-warnings or can be requested directly from CAT PUMPS.

WARRANTY

View the Limited Warranty on-line at www.catpumps.com/warranty.

ETERMINING THE PUMP R.P.M.

Rated gpm = "Desired" gpm.
 Rated rpm = "Desired" rpm

ETERMINING THE REQUIRE H.P.

gpm x psi = Electric Brake H. . Required
 1460

ETERMINING MOTOR PULLEY SIZE

Motor pulley O.D. = ump pulley O.D.
 ump rpm Motor rpm

See complete Drive Packages [Includes: Pulleys, Belts, Hubs, Key] Tech Bulletin 003. Refer to pump **Service Manual** for repair procedure additional technical information.

PARTS LIST

ITEM	PART NUMBER		DESCRIPTION		QTY	
	2510	MATL	2511	MATL		
2	990036	STL	990036	STL	Key (M8x7x40)	1
5	126544	STCP R	125753	S	Screw, HHC Sems (M8x25)	8
8	27773	AL	27773	AL	Cover, Bearing	2
10	27772	NBR	27772	NBR	O-Ring, Bearing Cover - 70D	2
11	27771	NBR	27771	NBR	Seal, Oil, Crankshaft - 70D	2
15	26512	STL R	26512	STL R	Bearing, Ball	2
20	48613	TNM	48613	TNM	Rod, Connecting Assembly (Includes: Lockwasher, Washer, Screw)	3
21	126562	STCP R	126562	STCP R	Washer, Locking	3
25	49795	FCM	49759	FCM	Crankshaft, Dual-End	1
31	828710	PE	828710	PE	Protector, Oil Cap w/Foam Gasket	1
32	43211	ABS	43211	ABS	Cap, Oil Filler	1
33	14177	NBR	14177	NBR	O-Ring, Oil Filler Cap - 70D	1
38	129343	RBR	129343	RBR	Gasket, Flat	1
39	27769	ABS	27769	ABS	Dip Stick	1
40	126544	STCP R	125753	S	Screw, HHC Sems (M8x25)	8
48	25625	STCP	25625	STCP	Plug, Drain (1/4"x19BSP)	1
49	23170	NBR	23170	NBR	O-Ring, Drain Plug - 70D	1
50	27768	AL	27768	AL	Cover, Rear	1
51	27767	NBR	27767	NBR	O-Ring, Rear Cover - 70D	1
53	27762	AL	27762	AL	Crankcase w/Guide Pins	1
54	27488	S	27488	S	Pin, Guide	2
56	27790	POP	27790	POP	Pan, Oil	1
59	92519	STZP	92538	S	Screw, HHC Sems (M6x16)	2
	125824	STCP R	—	—	Screw, HHC Sems (M6x16)	2
64	27784	CM	27784	CM	Pin, Crosshead	3
65	48719	SSHS	48719	SSHS	Rod, Plunger	3
70	27785	NBR	27785	NBR	Seal, Crankcase Oil - 70D	3
75	110669	S	110669	S	Slinger, Barrier	3
88	110670	S	110670	S	Washer, Keyhole	3
90	48535	CC	48535	CC	Plunger, Ceramic (M25x110)	3
95	126549	STCP R	48679	SS	Stud, Plunger Retainer (M7x103)	3
96	20184	PTFE	20184	PTFE	Back-up-Ring, Plunger Retainer	3
97	14190	NBR	14190	NBR	O-Ring, Plunger Retainer - 70D	3
	14161	FPM	14161	FPM	O-Ring, Plunger Retainer - 70D	3
98	44069	SS	44069	SS	Gasket, Plunger Retainer	3
99	44068	SS	44068	SS	Retainer, Plunger (M7)	3
100	110672	NY	110672	NY	Retainer, LPS, Front	3
	111116	NY	111116	NY	Retainer, LPS, Rear	3
101	48487	—	48487	—	Wick, Long Tab	3
106	44086	NBR	44086	NBR	Seal, LPS w/SS-Spg	3
	45846	FPM	45846	FPM	Seal, LPS w/SS-Spg	3
107	48537	BB	48668	SS	Washer, LPS	3
110	48536	BBCP	48667	SS	Manifold, Inlet	1
112	11379	NBR	11379	NBR	O-Ring, Inlet Manifold - 70D	3
	14183	FPM	14183	FPM	O-Ring, Inlet Manifold	3
117	126510	STCP R	88398	S	Screw, HSH (M12x35 and M12x40)	4
126	48538	BB	48669	D	Adapter, Female	3
127	44610	STG*	44610	STG*	V-Packing	6
128	48539	BB	113025	SS	Adapter, Male	3
141	48672	SS	48672	SS	Spring, Coil [12/02]	18
142	48550	BB	48670	SS	Spacer w/Coil Springs	3
155	17629	NBR	17629	NBR	O-Ring, Spacer-Rear - 80D	3
	14183	FPM	14183	FPM	O-Ring, Spacer-Rear	3
156	28243	PTFE	28243	PTFE	Back-up-Ring, Spacer-Rear	3
158	28243	PTFE	28243	PTFE	Back-up-Ring, Spacer-Front	3
159	17629	NBR	17629	NBR	O-Ring, Spacer-Front - 80D	3
	14183	FPM	14183	FPM	O-Ring, Spacer-Front	3
162	48363	D	48363	D	Back-up-Ring, Seat	6
163	26142	NBR	26142	NBR	O-Ring, Seat - 80D	6
	14330	FPM	14330	FPM	O-Ring, Seat - 70D	6
164	48544	SS	48676	SS	Seat	6
166	45839	SS	45839	SS	Valve	6
167	45840	SS	45840	SS	Spring	6
168	110682	PVDF	110682	PVDF	Retainer, Spring	6
170	44794	SS	44794	SS	Washer, Spring Retainer	6
171	48689	SS	48689	SS	Spring, Coil [12/02]	6
172	17667	NBR	17667	NBR	O-Ring, Valve Plug - 80D	6
	11745	FPM	11745	FPM	O-Ring, Valve Plug - 70D	6
174	120693	BBCP	49295	SS	Plug, Valve (w/O-Ring Model 2510 Only)	6
185	48543	BBCP	48674	SS	Manifold, Discharge	1
188	126511	STCP R	88399	S	Screw, HSH (M12x80)	6
250	26516	STCP	26516	STCP	Protector, Shaft	1
260	30614	STZP R	30614	STZP R	Mount, Rail, Assy	1
269	30206	F	30206	F	Pulley (10") [See Drive Packages, Tech Bulletin 003]	1
270	30059	STL	30059	STL	Hub, "H", M30 (Keyway M8) [See Drive Packages, Tech Bulletin 003]	1
279	30278	STZP	30278	STZP	Oilers (1 oz.)	3
281	30967	—	30967	—	Glass, Oiler	3
282	10069	NBR	10069	NBR	Gasket, Oiler	3

EXPLODED VIEW

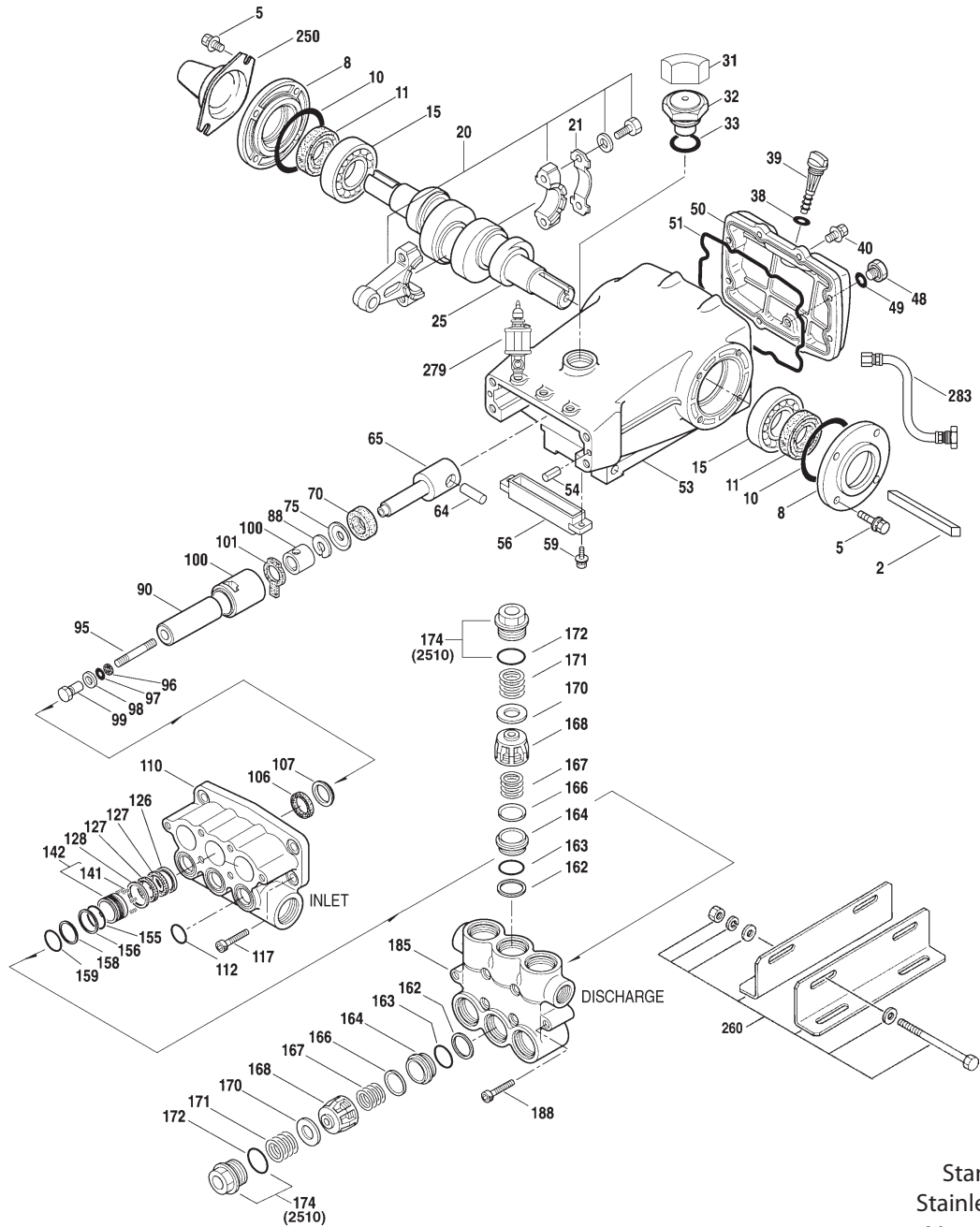

Models
Standard - 2510
Stainless Steel - 2511
November 2011

	2510	MATL	2511	MATL		
283	34334	—	34334	—	Kit, Oil Drain (3/8" x 24") (See Individual Data Sheet)	1
	76144	—	76144	—	Kit, Oil Drain (3/8" x 24") (See Individual Data Sheet)	1
290	6124	—	6124	—	Gasket, Liquid (3 oz)	1
299	816747	BBCP	816785	SS	Head, Complete	1
300	31280	NBR*	—	—	Kit, Seal (Incls: 97, 106, 112, 127, 155, 156, 158, 159)	1
	—	—	76180	NBR*	Kit, Seal w/FA (Incls: 97, 106, 112, 126, 127, 155, 156, 158, 159)	1
	31380	FPM*	31380	FPM*	Kit, Seal (Incls: 97, 106, 112, 127, 155, 156, 158, 159)	1
310	31285	NBR	31270	NBR	Kit, Valve (Incls: 162, 163, 164, 166, 167, 168, 170, 172)	2
	31385	FPM	31275	FPM	Kit, Valve (Incls: 162, 163, 164, 166, 167, 168, 170, 172)	2
—	714500	SS	714500	SS	C.A.T. (Inlet stabilizer for RO and boosted inlet applications)	1
—	714505	SS	714505	SS	Adapter (2 per C.A.T.) (See Data Sheet for complete selection)	2
—	6100	—	6100	—	Oil, Case (12 Bottles) ISO 68 Multi-viscosity Hydraulic (Fill to specified crankcase capacity prior to start-up)	1
—	—	—	6119	—	Lubricant, Anti-Seize (2 oz.)	1

Bold part numbers are unique to a particular pump model. Italics are optional items. [] Date of latest production change.
R Components comply with RoHS Directive. * Review material codes for individual items (STG generally may be used as alternate).
See Tech Bulletins 003, 024, 035, 036, 043, 074, 077, 083 and 085 for additional information.

C. A. T. highly recommended for pressurized inlet, R.O. and Industrial applications.

MATERIAL CODES (Not Part of Part Number): ABS=ABS Plastic AL=Aluminum BB=Brass BBCP=Brass/Chrome Plated CC=Ceramic CM=Chrome-Moly
D=Acetal F=Cast Iron FCM=Forged Chrome-Moly FPM=Fluorocarbon NBR=Medium Nitrile (Buna-N) NY=Nylon PE=Polyethylene POP=Polypropylene
PTFE=Pure Polytetrafluoroethylene PVDF=Polyvinylidene Fluoride S=304SS SS=316SS SSHS=316SS/High StrengthSTCP=Steel/Chrome Plated
STG=Special Blend PTFE White STL=Steel STZP=Steel/Zinc Plated TNM=Special High Strength

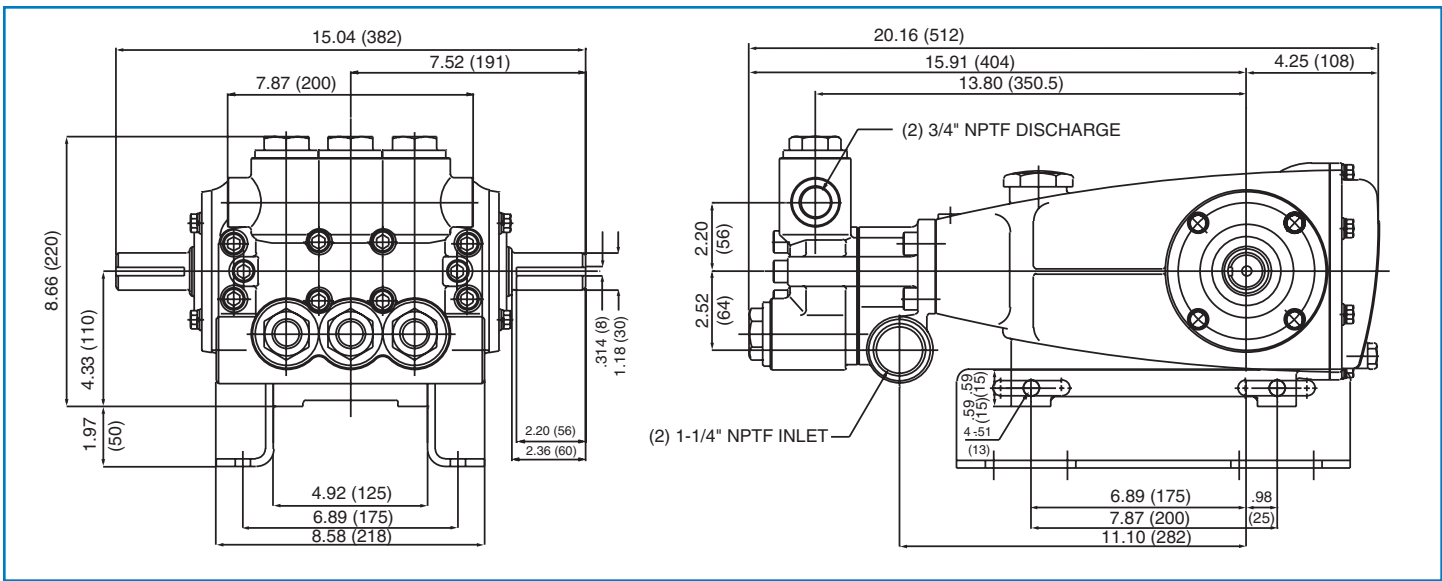

Models 2510, 2511

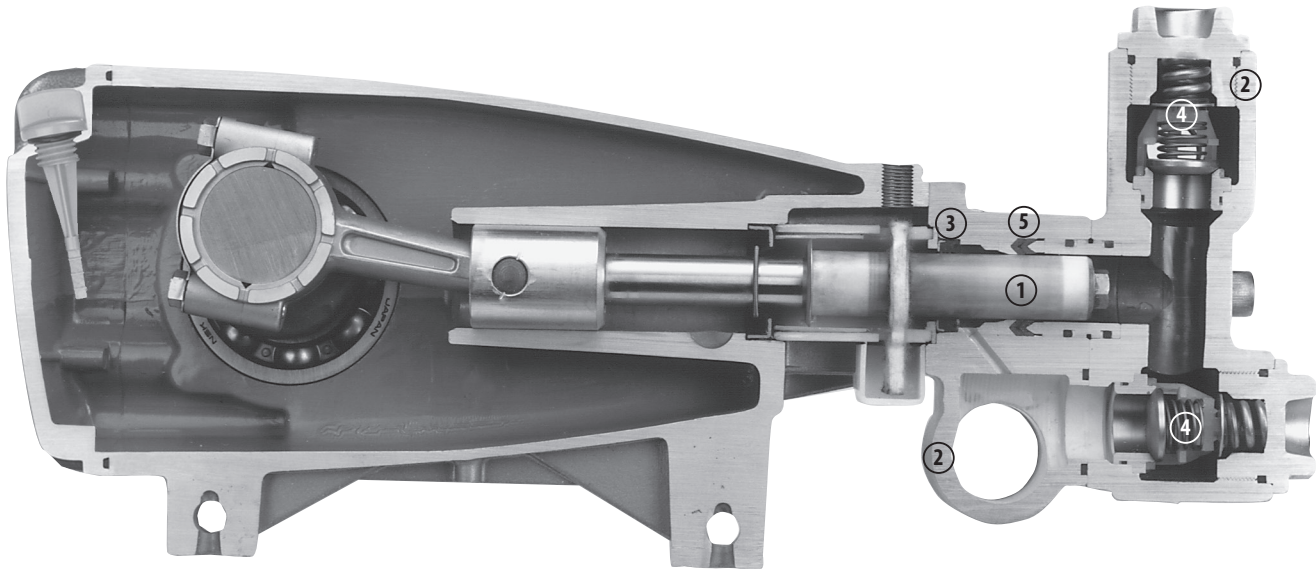

- 1 Special concentric, high-density, polished, solid ceramic **plungers** provide a true wear surface and extended seal life.
- 2 **Manifolds** are a high strength forged brass or stainless steel for long-term, continuous duty.
- 3 100% wet **seal** design adds to service life by allowing pumped liquids to cool and lubricate on both sides of seals.
- 4 Stainless steel **valves, seats and springs** provide corrosion-resistance, ultimate seating and extended life.
- 5 Specially formulated, CAT UM exclusive, **V-Packings** offer unmatched performance and seal life.



LENNTECH

info@lennotech.com
www.lennotech.com

Fax. +31-15-261.62.89
Tel. +31-15-261.09.00