

15 Frame Plunger Pump

Standard Brass Model

Stainless Steel Model

1530

1531

FEATURES

Superior Design

- Triplex plunger design gives smoother liquid flow.
- V-Packings are completely lubricated and cooled by the liquid being pumped.
- Inlet and discharge valve assemblies interchange for easier maintenance.
- Lubricated Lo-Pressure Seals provide double protection against external leakage.
- Oil bath crankcase assures optimum lubrication.
- Close tolerance concentricity of the ceramic plunger maximizes seal life.

Quality Materials

- Precision design 304 and 316 stainless steel valves and seats are hardened and polished for ultimate seating and extended life.
- Forged Brass or Stainless Steel manifolds are strong and corrosion resistance.
- Special concentric, high-density, polished, solid ceramic plungers provide a true wear surface and extended seal life.
- Specially formulated, CAT PUMP exclusive, V-Packings offer unmatched performance and seal life.
- Die cast aluminum crankcase provides high strength, minimum weight and precision tolerance control.
- Chrome-moly crankshaft gives unmatched strength and surface hardness.
- Oversized crankshaft bearings with greater loading capacity mean longer bearing life.

Easy Maintenance

- Wet-end is easily serviced without entering crankcase, requiring less time and effort.
- Preset packings mean no packing gland adjustment is necessary, reducing maintenance costs.

⚠ WARNING

All systems require both a primary pressure regulating device (i.e., regulator, unloader) and a secondary pressure safety relief device (i.e., pop-off valve, safety valve). Failure to install such relief devices could result in personal injury or damage to the pump or to system components. CAT PUMPS does not assume any liability or responsibility for the operation of a customer's high pressure system.

SPECIFICATIONS

	U.S. Measure	Metric Measure
Flow	15.6 GPM	(59 L/M)
Pressure Range.	100 to 1500 PSI	(7 to 105 BAR)
RPM	1450 RPM	(1450 RPM)
Inlet Pressure Range.		
Flooded to 70 PSI (Flooded to 4.9 BAR)		
Bore.	0.984"	(25 mm)
Stroke.	1.181"	(30 mm)
Crankcase Capacity	42 oz.	(1.26 L)
Maximum Liquid Temperature	140 °F	(60 °C)
Above 130°F call CAT PUMPS for inlet conditions and elastomer recommendations.		
Inlet Ports (2) .1" NPTF	(1" NPTF)	
Discharge Ports (2).		
.3/4" NPTF	(3/4" NPTF)	
Pulley Mounting .		
.Either Side	(Either Side)	
Shaft Diameter	1.181"	(30 mm)

ELECTRIC HORSEPOWER REQUIREMENTS

FLOW		PRESSURE			RPM
U.S. GPM	L/M	PSI 1000 BAR 70	PSI 1200 BAR 85	PSI 1500 BAR 105	
15.6	59	10.7	12.8	16.0	1450
14.0	53	9.6	11.5	14.4	1301
12.0	45	8.2	9.9	12.4	1115

DETERMINING THE PUMP R.P.M.	$\frac{\text{Rated G.P.M.}}{\text{Rated R.P.M.}}$	=	$\frac{\text{"Desired" G.P.M.}}{\text{"Desired" R.P.M.}}$
DETERMINING THE REQUIRED H.P.	$\frac{\text{GPM} \times \text{PSI}}{1460}$	=	Electric Brake H. P. Required
DETERMINING MOTOR PULLEY SIZE	$\frac{\text{Motor Pulley O.D.}}{\text{Pump R.P.M.}}$	=	$\frac{\text{Pump Pulley O.D.}}{\text{Motor R.P.M.}}$

See complete Drive Packages [Incls: Pulleys, Belts, Hubs, Key] Tech Bulletin 003.
Refer to pump Service Manual for repair procedure, additional technical information and pump warranty.

PARTS LIST

ITEM	PART NUMBER		DESCRIPTION		QTY	
	1530	MATL	1531	MATL		
2	990036	STL	990036	STL	Key (M8x7x40)	1
	30067	STL	30067	STL	Key (M8x7.5x25)	1
5	92519	STZP	92538	S	Screw, Sems HHC (M6x16)	8
	125824	STCP R	—	—	Screw, Sems HHC (M6x16)	8
8	43496	AL	43496	AL	Cover, Bearing	2
10	11340	NBR	11340	NBR	O-Ring, Bearing Cover - 70D	2
11	43495	NBR	43495	NBR	Seal, Oil, Crankshaft - 70D	2
12	815281	FBR	815281	FBR	Shim, Split 2 pc	0-6
13	814800	S	814800	S	Shim, Split 2 pc	0-4
15	39060	STL	39060	STL	Bearing, Roller	2
20	48600	TNM	48600	TNM	Rod, Connecting Assembly	3
25	43494	FCM	43494	FCM	Crankshaft, Dual-End	1
31	828710	—	828710	—	Protector, Oil Cap w/Foam Gasket	1
32	43211	ABS	43211	ABS	Cap, Oil Filler	1
33	14177	NBR	14177	NBR	O-Ring, Filler Cap - 70D	1
37	92241	—	92241	—	Gauge, Oil, Bubble w/Gasket - 80D	1
38	44428	NBR	44428	NBR	Gasket, Flat, Oil Gauge - 80D	1
40	92520	STZP	92542	S	Screw, Sems HHC (M6x20)	4
	126541	STCP R	—	—	Screw, Sems HHC (M6x20)	4
48	25625	STCP	25625	STCP	Plug, Drain (1/4"x19BSP)	1
49	23170	NBR	23170	NBR	O-Ring, Drain Plug - 70D	1
50	43491	AL	43491	AL	Cover, Rear	1
51	44834	NBR	44834	NBR	O-Ring, Rear Cover - 70D	1
53	115471	AL	115471	AL	Crankcase w/Guide Pins	1
56	44664	POP	44664	POP	Pan, Oil	1
64	43507	CM	43507	CM	Pin, Crosshead	3
65	48228	SHS	48360	SSHS	Rod, Plunger	3
69	126592	STCP R	126592	STCP R	Washer, Oil Seal	3
70	43500	NBR	43500	NBR	Seal, Oil Crankcase - 80D	3
75	43506	S	43506	S	Slinger, Barrier	3
90	48606	CC	48606	CC	Plunger, Ceramic (M25x92)	3
96	43235	PTFE	43235	PTFE	Back-up-Ring, Plunger Retainer	3
95	—	—	89651	SS	Stud, Plunger Retainer (M6x70)	1
97	17399	NBR	17399	NBR	O-Ring, Plunger Retainer - 80D	3
	14160	FPM	14160	FPM	O-Ring, Plunger Retainer - 70D	3
	◆ 46204	EPDM	◆ 46204	EPDM	O-Ring, Plunger Retainer - 70D	3
98	45891	CU	44041	SS	Gasket, Plunger Retainer	3
99	104360	S	44031	SS	Retainer, Plunger	3
100	899509	POP	899509	POP	Retainer, Seal 2-Pc [07/06]	3
101	48716	—	48716	—	Wick, Long Tab	3
106	44086	NBR	44086	NBR	Seal, LPS w/SS-Spg	3
	45846	FPM	45846	FPM	Seal, LPS w/SS-Spg	3
	◆ 49196	EPDM	◆ 49196	EPDM	Seal, LPS w/SS-Spg	3
110	48608	FBB	48683	SS	Manifold, Inlet	1
112	14200	NBR	14200	NBR	O-Ring, Inlet Manifold - 70D	3
	11719	FPM	11719	FPM	O-Ring, Inlet Manifold	3
	◆ 48907	EPDM	◆ 48907	EPDM	O-Ring, Inlet Manifold	3
117	87933	STZP	87952	S	Screw, HSH (M10x55)	4
	126515	STCP R	—	—	Screw, HSH (M10x55)	4
126	48538	BB	48669	SS	Adapter, Female	3
127	44610	STG*	44610	STG*	V-Packing	6
128	48539	BB	113025	SS	Adapter, Male	3
141	48672	SS	48672	SS	Spring, Coil [12/02]	18
142	48550	BB	48670	SS	Spacer w/Coil Springs	3
155	17629	NBR	17629	NBR	O-Ring, Spacer - 80D	6
	14183	FPM	14183	FPM	O-Ring, Spacer	6
	◆ 701784	EPDM	◆ 701784	EPDM	O-Ring, Spacer	6
156	28243	PTFE	28243	PTFE	Back-up-Ring, Spacer	6
162	48363	D	48363	D	Back-up-Ring, Seat	6
163	26142	NBR	26142	NBR	O-Ring, Seat - 80D	6
	14330	FPM	14330	FPM	O-Ring, Seat	6
	◆ 701493	EPDM	◆ 701493	EPDM	O-Ring, Seat	6
164	48596	S	48688	SSL	Seat, Q.V. Stepped	6
166	48686	SSL	48686	SSL	Valve, Q.V.	6
167	48687	SS	48687	SS	Spring, Valve [12/02]	6
168	44735	PVDF	44735	PVDF	Retainer, Spring	6
170	44794	SS	44794	SS	Washer, Spring Retainer	6
171	48689	SS	48689	SS	Spring, Coil [12/02]	6
172	17629	NBR	17629	NBR	O-Ring, Valve Plug - 80D	6
	14183	FPM	14183	FPM	O-Ring, Valve Plug	6
	◆ 701784	EPDM	◆ 701784	EPDM	O-Ring, Valve Plug	6
174	48597	FBB	49294	SS	Plug, Valve	6
185	48610	FBB	48685	SS	Manifold, Discharge	1
188	89980	STCP	89981	S	Screw, HSH (M12x70)	6
	126519	STCP R	—	—	Screw, HSH (M12x70)	6

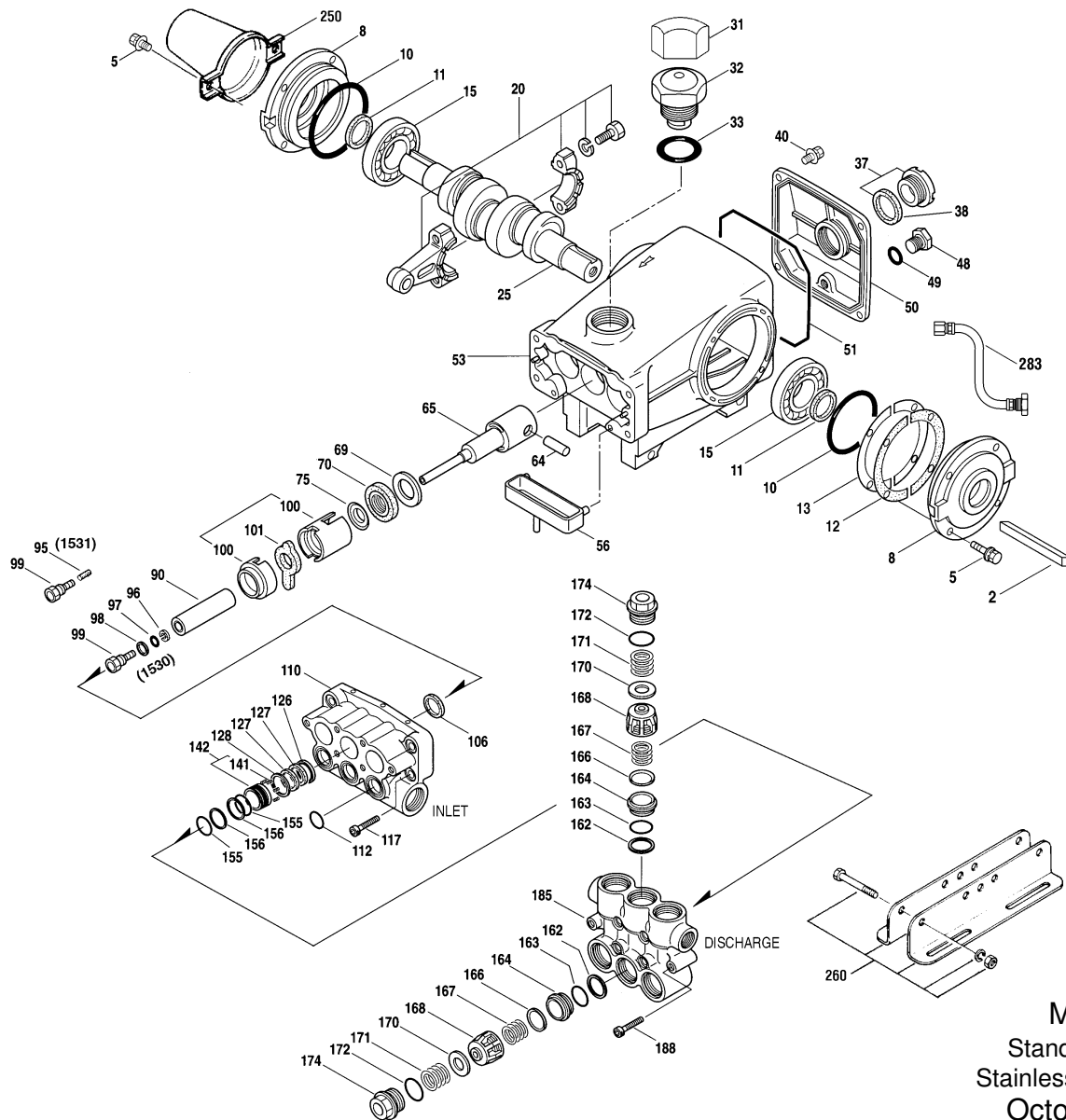

Models
 Standard - 1530
 Stainless Steel - 1531
 October 2007

	1530	MATL	1531	MATL		
250	30764	NY	30764	NY	Protector, Shaft w/2 Screws	1
260	30613	STZP	30613	STZP	Rail, Angle Assy	1
269	30206	F	30206	F	Pulley (10") [See Drive Packages, Tech Bulletin 003]	1
270	30059	STL	30059	STL	Hub, "H", M30 (Keyway M8) [See Drive Packages, Tech Bulletin 003]	1
	990012	STL	990012	STL	Hub, "B", M30 (Keyway M8) [See Drive Packages, Tech Bulletin 003]	1
283	34334	—	34334	—	Kit, Oil Drain	1
290	6124	—	6124	—	Liquid Gasket, Hylomar (3 oz.)	1
299	816762	FBB	816783	SS	Head, Complete	1
300	31355	NBR	31355	NBR	Kit, Seal (Incls: 97,106,112,127,155,156)	1
	31455	FPM*	31455	FPM*	Kit, Seal (Incls: 97,106,112,127,155,156)	1
	◆ 31753	EPDM	◆ 31753	EPDM	Kit, Seal (Incls: 97,106,112,127,155,156)	1
310	31360	NBR	31271	NBR	Kit, Valve (Incls: 162,163,164,166,167,168,170,172)	2
	31460	FPM	31281	FPM	Kit, Valve (Incls: 162,163,164,166,167,168,170,172)	2
	◆ 31773	EPDM	◆ 31773	EPDM	Kit, Valve (Incls: 162,163,164,166,167,168,170,172)	2
—	711500	SS	711500	SS	C.A.T. (inlet pressure stabilizer for RO and boosted inlet applications)	1
—	711504	SS	711504	SS	Adapter (2 per C.A.T.) (See Data Sheet for complete selection)	2
—	6100	—	6100	—	Oil, Case (12 Bottles) ISO 68 Multi-viscosity Hydraulic (Fill to specified crankcase capacity prior to start-up)	1
—	—	—	6119	—	Lubricant, Antiseize (1 oz.)	1

Bold print part numbers are unique to a particular pump model. Italics are optional items. [] Date of latest production change. ◆ Silicone oil/grease required.
 R Components comply with RoHS Directive. * Review material codes for individual items (STG generally may be used as alternate).
 See Tech Bulletins 002, 003, 024, 035, 036, 043, 053, 074, 077, 083, 085, 095 and 098 for additional information.

C.A.T. highly recommended for pressurized inlet, R.O. and Industrial applications.

MATERIAL CODES (Not Part of Part Number): ABS=ABS Plastic AL=Aluminum BB=Brass CC=Ceramic CM=Chrome-moly CU=Copper D=Acetal F=Cast Iron
 FBB=Forged Brass FBR=Fiber FCM=Forged Chrome-moly FPM=Fluorocarbon NBR=Medium Nitrile (Buna-N) NY=Nylon POP=Polypropylene
 PTFE=Pure Polytetrafluoroethylene PVDF=Polyvinylidene Fluoride S=304SS SHS=304SS/High Strength SS=316SS SSS= 316SS/High Strength
 SSL=316SS/Low Carbon STCP=Steel/Chrome Plated STG=Special Blend PTFE White STL=Steel STZP=Steel/Zinc Plated TNM=Special High Strength

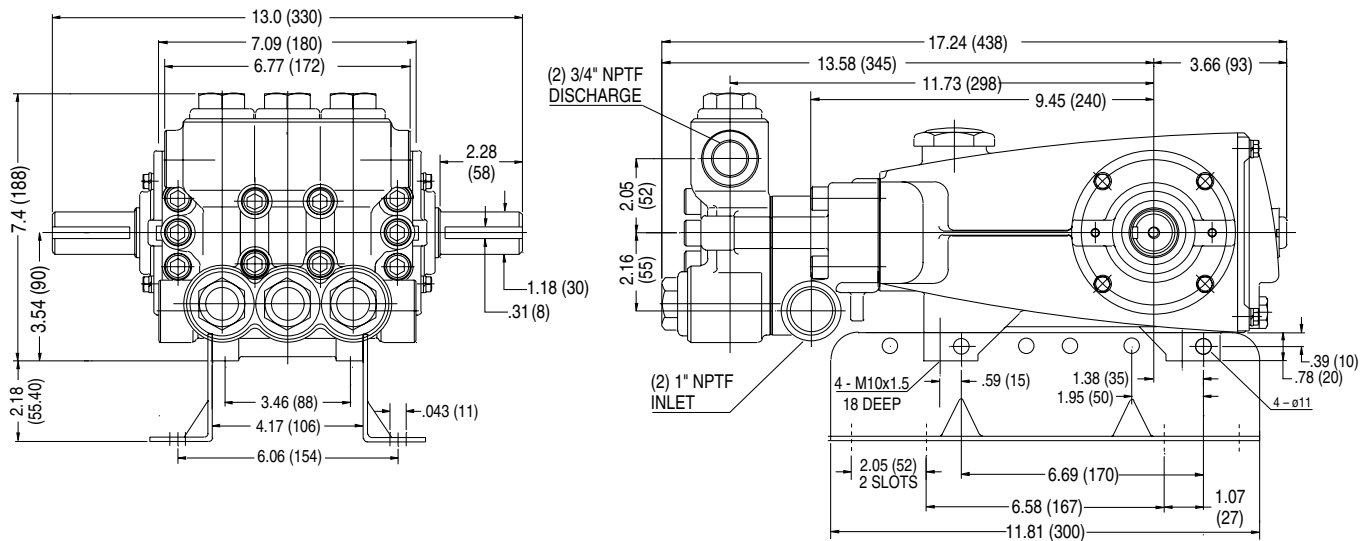

Models 1530, 1531

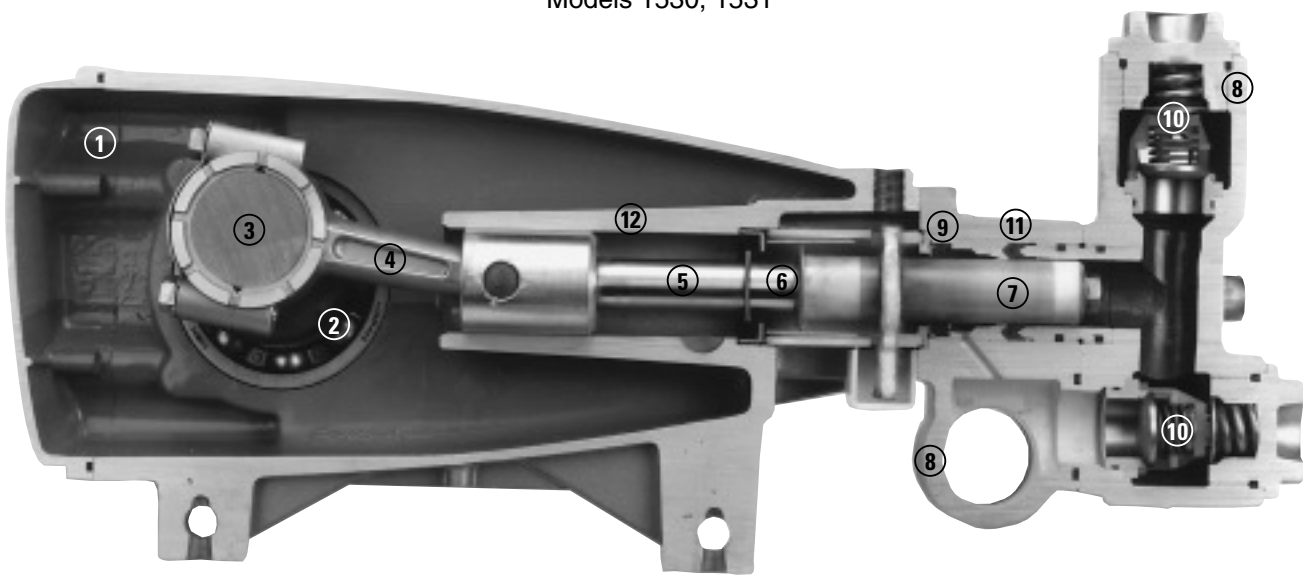

- 1 Die cast aluminum **crankcase** means high strength, light weight, and excellent tolerance control.
- 2 Oversized crankshaft **bearings** provide extended bearing life and pump performance.
- 3 Chrome-moly **crankshaft** provides unmatched strength and surface hardness for long life.
- 4 Matched oversized high strength **connecting rods** are noted for superior strength and bearing quality.
- 5 Special stainless steel **plunger rods** with high strength crossheads for longevity and corrosion resistance.
- 6 The stainless steel **slinger** provides back-up protection for the crankcase seal, keeping pumped liquids out of the crankcase.
- 7 Special concentric, high-density, polished, solid ceramic **plungers** provide a true wear surface and extended seal life.
- 8 **Manifolds** are a high strength forged brass or stainless steel for long-term, continuous duty.
- 9 100% wet **seal** design adds to service life by allowing pumped liquids to cool and lubricate on both sides of seals.
- 10 Stainless steel **valves, seats and springs** provide corrosion-resistance, ultimate seating and extended life.
- 11 Specially formulated, CAT PUMP exclusive, **V-Packings** offer unmatched performance and seal life.
- 12 **Crossheads** are 360° supported for uncompromising alignment.



LENNTECH

info@lennotech.com

Fax. +31-15-261.62.89

www.lennotech.com

Tel. +31-15-261.09.00