



Alfa Laval AlfaVap 700

Gasketed plate-and-frame heat exchanger for evaporating applications

Alfa Laval AlfaVap is a tailor-made rising film plate evaporator that is based on Alfa Laval's semi-welded technology. The product evaporates in the gasketed channel while the steam heating medium condenses in the welded channel. AlfaVap can be used in evaporation systems and as a thermosiphon reboiler. A large range of plate and gasket types is available.

Applications

- Biotech and Pharmaceutical
- Chemicals
- Energy and Utilities
- Food and Beverages
- Water and Waste treatment

Benefits

- Low hold-up volume – quick start-up and shut-down as well as fast process control
- High energy efficiency – low operating cost
- Easy to install – compact design
- High serviceability – easy to open for inspection and cleaning and easy to clean by CIP
- Access to Alfa Laval's global service network

Features

Every detail is carefully designed to ensure optimal performance, maximum uptime and easy maintenance. Selection of available features:

- 5-point alignment system
- Reinforced hanger
- Clip-on gasket
- Leak chamber
- Bearing box
- Fixed bolt head
- Key hole bolt opening
- Lifting lug
- Lining
- Lock washer
- Pressure plate roller
- Tightening bolt cover

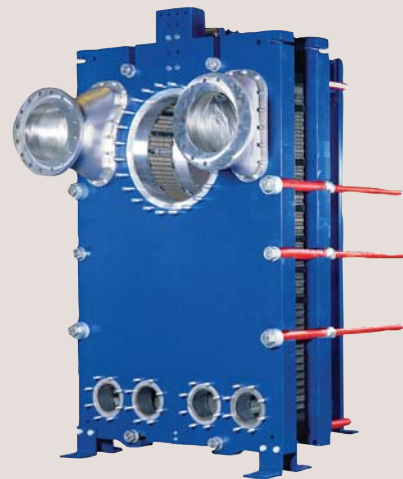

Extending performance

with Alfa Laval 360° Service Portfolio

Our extensive services ensure top performance from your Alfa Laval equipment throughout its life cycle. The availability of parts and our team's commitment and expertise bring you peace of mind.

Start-up

- Installation
- Installation Supervision
- Commissioning

Maintenance

- Cleaning Services
- Reconditioning
- Repair
- Service Tools
- Spare Parts

Support

- Exclusive Stock
- Technical Documentation
- Telephone Support
- Training
- Troubleshooting

Improvements

- Equipment Upgrades
- Redesign
- Replacement and Retrofit

Monitoring

- Condition Audit
- Performance Audit

Dimensional drawing

Measurements mm (inches)

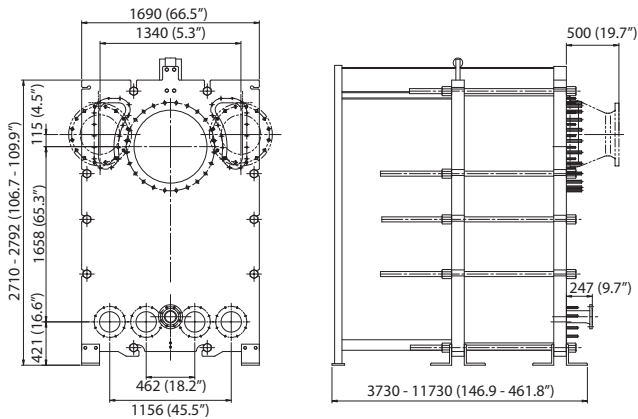

Technical data

Plates

Name	Type	Free channel, mm (inches)
EC700-W	Semi-welded	6 / 6 (0.24 / 0.24)

Materials

Heat transfer plates	316/316L Ti
Field gaskets	NBR, EPDM
Ring gaskets	NBR, EPDM, FKM
Flange connections	Metal lined: stainless steel, nickel, titanium
Frame and pressure plate	Carbon steel, epoxy painted

Other materials may be available on request.

All option combinations may not be configurable.

Operational data

Frame, PV-code	Max. design pressure ¹ (barg/psig)	Max. design temperature (°C/°F)
FM, pvcALS	6.0/87 (6.0/87)	180/356 (180/356)
FM, ASME	5.7/83 (5.7/83)	180/356 (180/356)
FM, PED	6.0/87 (6.0/87)	180/356 (180/356)

1. Values for Product channel (Steam channel)

Extended pressure and temperature rating may be available on request.

Connections

Product inlet	2 x EN1092-1 DN200 PN10 2 x ASME B16.5 Class 150 NPS 8 2 x JIS B2220 10K 200A
Product outlet	EN1092-1 DN700 PN10 ASME B16.5 Class 150 NPS 28 JIS B2220 10K 700A
Steam inlet	EN1092-1 DN400 PN10 ASME B16.5 Class 150 NPS 16 JIS B2220 10K 700A
Condensate outlets	2 x EN1092-1 DN200 PN10 2 x ASME B16.5 Class 150 NPS 8 2 x JIS B2220 10K 200A